

# PRESA DI FORZA A COMANDO PNEUMATICO

## PNEUMATIC CLUTCH POWER TAKE-OFF

**CODICE PTO**  
PTO CODE

**2-77**

**CAMBIO**  
GEARBOX

**IVECO**  
**SPR 2865.6**

Codice foglio: 997-202-07717 Rev://

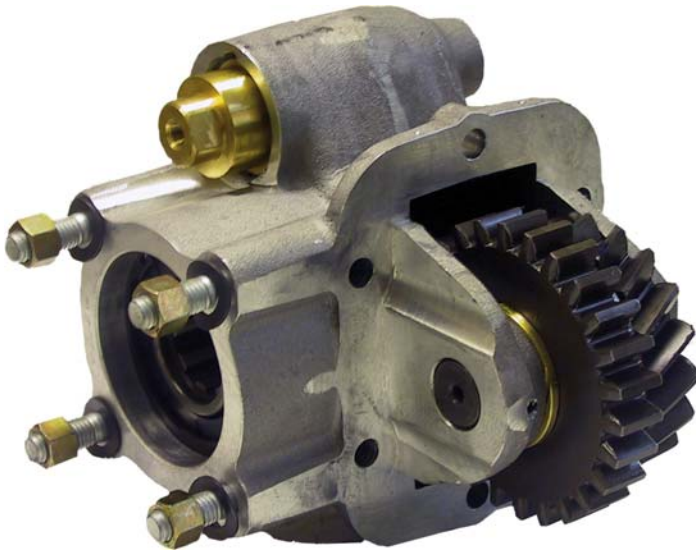

### DIAGRAMMA DI UTILIZZO WORKING CONDITION

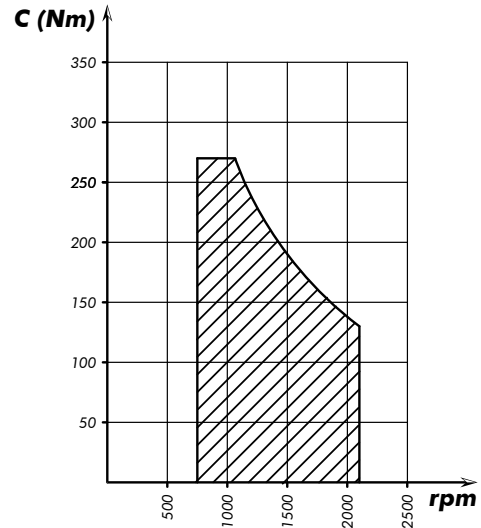

Rev://  
Codice fascicolo:

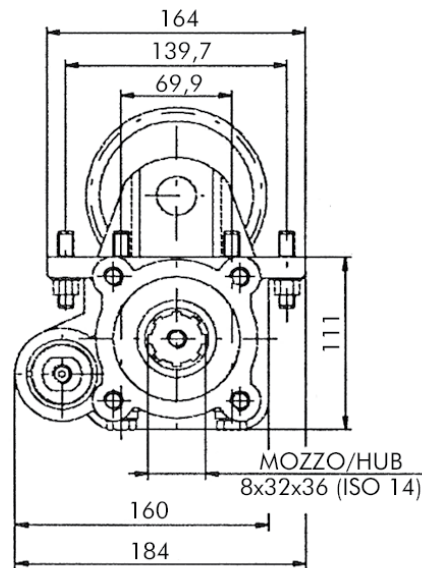
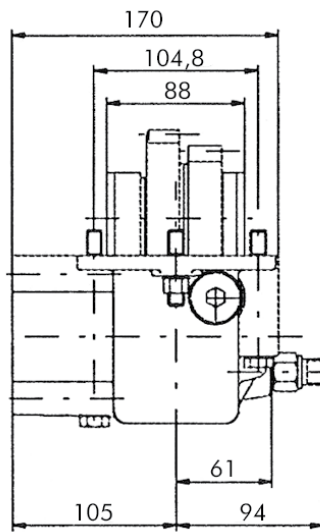

Data: Lunedì 22 dicembre 2003

Tipo cambio Gearbox	Codice PTO PTO code	Versione Version	Giri pto a 1000 giri motore Pto ratio@1000 eng.rpm	Coppia massima Max torque	Lato montaggio Mounting side	Uscita Output	Rotazione Rotation	Kit di montaggio Mounting kit	Peso Weight
			rpm	Nm					Kg
<b>SPR 2865.6/9,00</b>	<b>2-77-175</b>	17	957	<b>270</b>	Dx Right	Post. Rear	Ora. Cw	154-0-22	8,5

pag.1



O.M.F.B. S.p.A. Hydraulic Components  
We reserve the right to make any changes without notice.  
Edition 2003.12 No reproduction, however partial, is permitted.  
Via Cave, 7/9 25050 Provaglio d'Iseo (Brescia) Italy Tel.: +39.030.9830611  
Fax: +39.030.9839207-208 Internet:www.omfb.it e-mail:info@omfb.it

COMPANY WITH  
QUALITY SYSTEM  
CERTIFIED BY DNV GL  
= ISO 9001 =