

POMPE A PISTONI AD ASSE INCLINATO

BENT AXIS PISTON PUMPS

CODICE FAMIGLIA
FAMILY CODE

601-001
603-001

"HDS"
"MDS"

Flangia/Flange
Albero/Shaft
Cilin./Displ.

ISO
ISO14 8x32x36
84-108-130

Codice fascicolo: 997-400-60010 Rev.: AL



Fluido idraulico Fluid	Minerale o sintetico compatibile con guarnizioni: Mineral or synthetic compatible with the following seals: FKM, FPM, HNBR				
Viscosità cinematica consigliata Kinematic viscosity suggested	T media ambiente (°C) Average ambient temp. (°C)	< -40	-40 ÷ 10	10 ÷ 35	> 35
	VG (cSt = mm ² /s)	16	22	32	46
Viscosità cinematica ottimale di esercizio Optimale kinematic viscosity		VG = 10 cSt ÷ 100 cSt			
Viscosità cinematica max consentita all'avviamento Max kinematic viscosity suggested at the start-up		VG = 750 cSt			
Indice di viscosità consigliato Viscosity index suggested	VI > 100	Temperatura di esercizio Working temperature -40°C ÷ 140°C			
Grado di filtrazione Oil filtering		> 200 bar: 10 µm < 200 bar: 25 µm			
Pres. di aspirazione Inlet pressure		0,85 ÷ 2 bar assoluti/absolut			
Senso di rotazione Pump rotation		Unidirezionale (Dx o Sx) Unidirectional (Right or Left)			
Verificare che la pompa sia posizionata almeno 100 mm sotto il livello minimo del serbatoio olio. Prima di avviare la pompa effettuare spurgo aria. Verify that pump is, at least, 100 mm under the minimum level of the tank. Before starting the pump bleed the air.					

Data: Martedì 7 marzo 2017

Rev.: AB

Codice foglio: 997-601-01520

Dimensions in mm

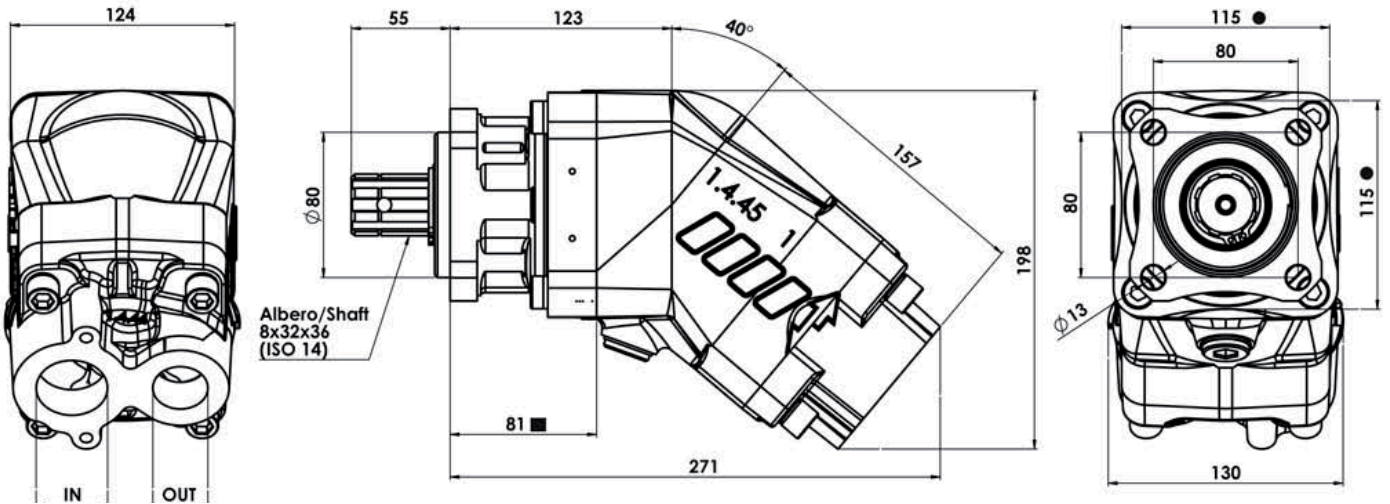

● Larghezza minima corpo a quota indicata ■
Minimum bodywidth at indicated measurement

Tipo pompa Pump type	Rotazione Rotation		IN	OUT
	Destra Right	Sinistra Left		
HDS-84	601-001-10843	601-001-10849	ISO 228 G 1 1/4"	ISO 228
HDS-108	601-001-11083	601-001-11089	G 1 1/2"	G 1"
MDS-130	603-001-11303	603-001-11309		
HDS-84	601-001-50843	601-001-50849	ISO 725	ISO 725
HDS-108	601-001-51083	601-001-51089	1 7/8-12 UN-2B SAE 24	1 5/16-12 UN-2B SAE 16
MDS-130	603-001-51303	603-001-51309		

pag. 35

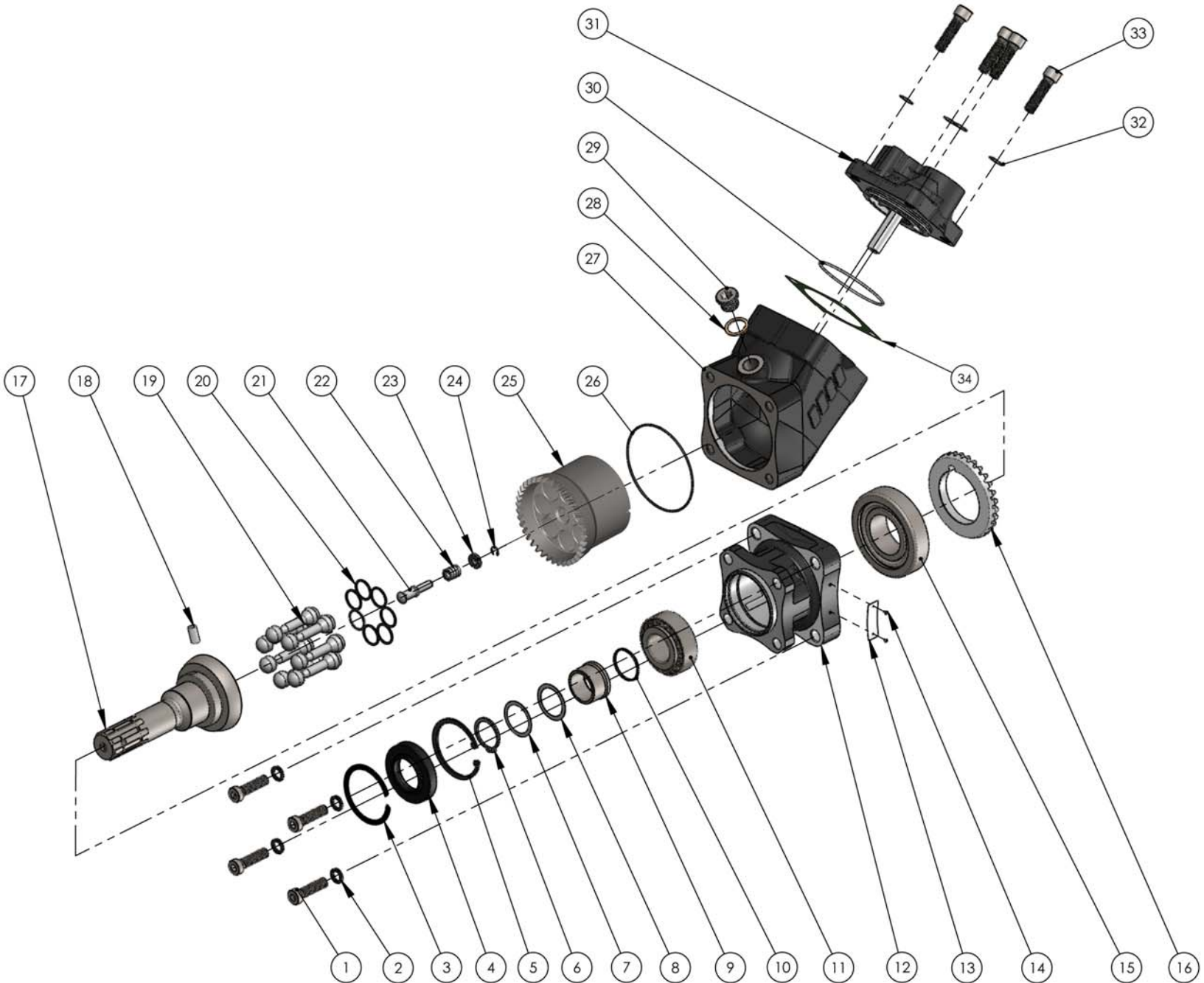

pag. 36

O.M.F.B. S.p.A. Hydraulic Components

We reserve the right to make any changes without notice.

Edition 2016.06 No reproduction, however partial, is permitted.

Via Cava, 7/9 25050 Provedolo (Isere) (Brescia) Italy Tel.: +39 030.9830611

Fax: +39 030.9839207-208 Internet: www.omfb.it e-mail: comatitf@omfb.it

COMPANY WITH
QUALITY SYSTEM
CERTIFIED BY DNV GL
= IATF 16949 =





O.M.F.B. S.p.A. Hydraulic Components
 We reserve the right to make any changes without notice.
 Edition 2016.06 No reproduction, however partial, is permitted.
 Via Cove, 719 25050 Povoaglio d'Isèo (Brescia) Italy Tel.: +39 030 9830611
 Fax: +39 030 9839207208 Internet: www.omfb.it e-mail: comfthi@omfb.it

pag. 37

COMPANY WITH
 QUALITY SYSTEM
 CERTIFIED BY DNV GL
 = IATF 16949 =

N° N°	HDS 84		HDS 108		MDS 130		Codice P. Number	Descrizione Description	Quantità Quantity	
	GAS	SAE	GAS	SAE	GAS	SAE				
1	•	•	•	•	•	•	502-005-00573	Vite TCE M12x45	Socket head capscrew	4
2	•	•	•	•	•	•	501-020-00129	Rosetta elastica	Washer	4
3	•	•	•	•	•	•	501-000-02729	Anello elastico	Circlip	1
4	•	•	•	•	•	•	506-000-24272	Paraolio	Oil seal	1
5	•	•	•	•	•	•	501-001-00677	Anello elastico	Circlip	1
6	•	•	•	•	•	•	501-000-01355	Anello seeger rinforzato	Retaining ring	1
7	•	•	•	•	•	•	529-007-01127	Rondella	Spacers	2
8	•	•	•	•	•	•	529-007-00226	Rondella	Spacers	2
9	•	•	•	•	•	•	511-002-00200	Bussola	Bushing	1
10	•	•	•	•	•	•	506-000-13137	Guarnizione OR	O-ring	1
11	•	•	•	•	•	•	510-002-00364	Cuscinetto a rulli conici	Tapered roller bearing	1
12	•	•	•	•	•	•	517-002-01172	Corpo anteriore	Front housing	1
13	•	•	•	•	•	•	513	Targhetta completa	Plate	1
14	•	•	•	•	•	•	513-000-00011	Chiodino fissaggio targhetta	Plate nail	2
15	•	•	•	•	•	•	510-002-00355	Cuscinetto a rulli conici	Tapered roller bearing	1
16	•	•	•	•	•	•	525-011-00273	Corona dentata	Crown	1
17	•	•	•	•	•	•	522-005-00562	Albero	Shaft	1
18	•	•	•	•	•	•	501-003-06142	Spina UNI 6364	Pin UNI 6364	1
19	•	•					532-005-00034			
			•	•			532-005-00070	Pistone sferico	Piston	7
					•	•	532-005-00105			
20	•	•					501-023-00037			
			•	•			501-023-00055	Fasce elastiche	Spring rings	21
					•	•	501-023-00117			
21	•	•	•	•	•	•	542-001-00162	Perno sferico con guida albero	Shaft guide pin	1
22	•	•	•	•	•	•	512-005-00812	Molla di carico corpo cilindri	Spring	1
23	•	•	•	•	•	•	542-001-00171	Anello guida molla	Spring guide ring	1
24	•	•	•	•	•	•	501-015-00028	Anello seeger	Retaining ring	1
25	•	•					500-029-16084			
			•	•			500-029-16108	Gruppo corpo cilindri sede pistoni	Piston barrel assembly	1
					•	•	500-029-16130			
26	•	•	•	•	•	•	506-000-12412	Guarnizione OR	O-Ring	1
27	•	•	•	•	•	•	517-002-01412	Corpo intermedio	Int. housing	1
28	•	•	•	•	•	•	115-006-00135	Tappo cieco	Blank plug	1
29	•	•	•	•	•	•	116-009-10129	Rondella rame	Copper washer	1
30	•	•	•	•	•	•	506-000-18520	Guarnizione OR	O-ring	1
31	•						500-029-90848			
		•					500-029-90857			
			•				500-029-91089	Gruppo corpo posteriore	Rear cover assembly	1
				•			500-029-91098			
					•		500-029-91301			
					•	500-029-91310				
32	•	•	•	•	•	•	501-020-00129	Rosetta elastica	Washer	4
33	•	•	•	•	•	•	502-005-00573	Vite TCE M12x45	Socket head capscrew	4
34	A	A	A	A	A	A	507-000-00247			
	A	A	A	A	A	A	507-000-00541	Guarnizione piatta	Gasket	1

A = alternative

CARATTERISTICHE TECNICHE DI FUNZIONAMENTO / TECHNICAL FEATURES

Tipo pompa Pump type	Cilindrata Displacement cm ³ /rev	Pressione Pressure		Velocità / Speed			Velocità min. Min. speed rpm	Peso Weight kg
		P1 bar	P3 bar	V0 rpm	V1 rpm	V2 rpm		
HDS-84	84.33	350	400	2300	1500	2000	300	18,9
HDS-108	107							18,5
MDS-130	131.62	250	270					18,3

P1=Pressione massima continua Max. continuous pressure (100%)
P3=Pressione massima di punta Max. peak pressure (6 sec.max)

V0=Massima continua vuoto Max. continuous speed without load
V1=Massima continua Max. continuous speed
V2=Massima intermittente Max. intermittent speed

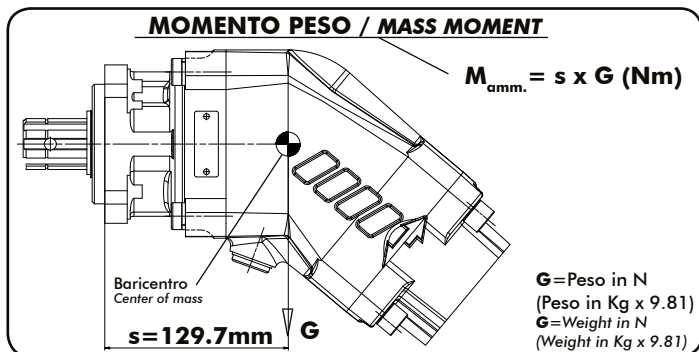
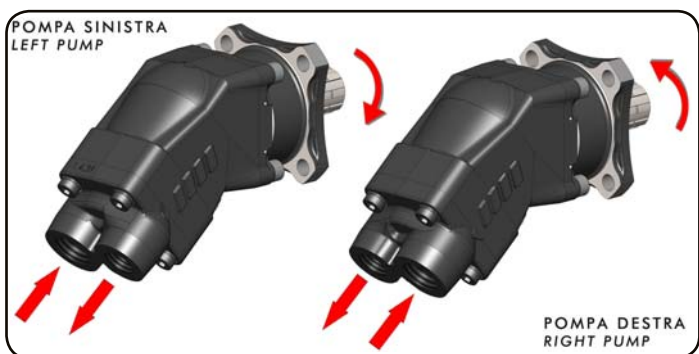
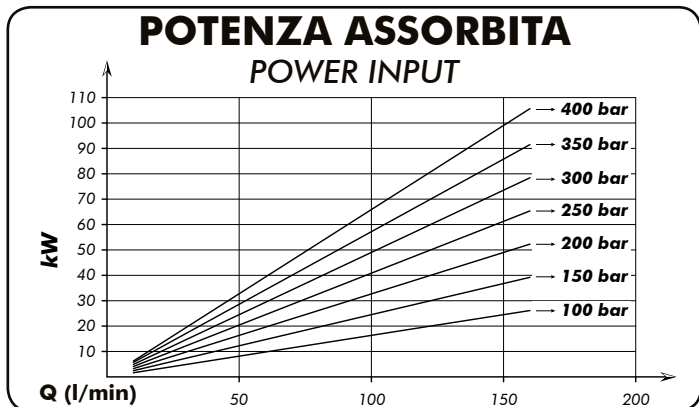
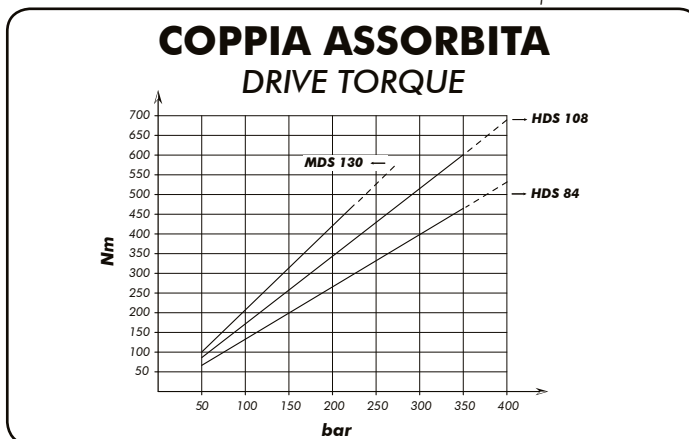
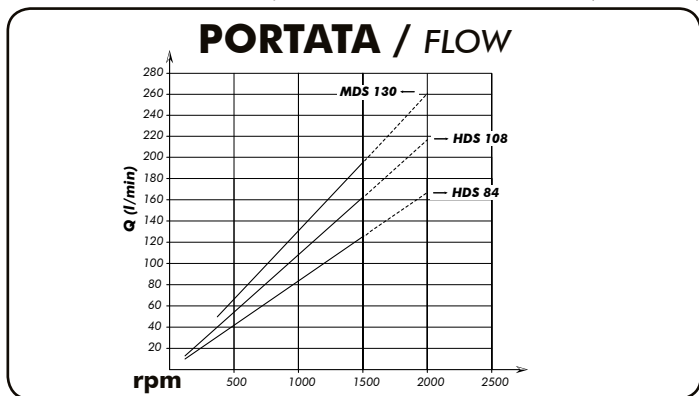

SCELTA DEL TUBO DI ASPIRAZIONE HOW TO CHOOSE THE SUCTION PIPE SIZE

Q Portata Flow l/min	interno min. tubo Min pipe diam. mm	inch	Velocità flusso Flow speed (m/s)
20	25	1"	0,68
30	32	1" 1/4	0,62
40	32	1" 1/4	0,83
50	38	1" 1/2	0,74
60	38	1" 1/2	0,88
70	40	1" 9/16	0,93
80	45	1" 3/4	0,84
90	45	1" 3/4	0,94
100	50	2"	0,85
110	50	2"	0,93
120	60	2"	0,71
130	60	2" 3/8	0,77
140	60	2" 3/8	0,83
150	60	2" 3/8	0,88
160	63	2" 1/2	0,86
170	63	2" 1/2	0,91
180	63	2" 1/2	0,96

Per garantire corrette condizioni di aspirazione la velocità del flusso non deve superare 1 m/sec.
To ensure the proper suction pipe size the flow speed should not exceed 1mt/sec.

Kit guarnizioni / Seal Kit
108-903-84009