

# Explosion-proof solenoid valves with suppressor diode

on/off directional and leak-free - Multicertification ATEX, IECEx, EAC

**Available only on request**

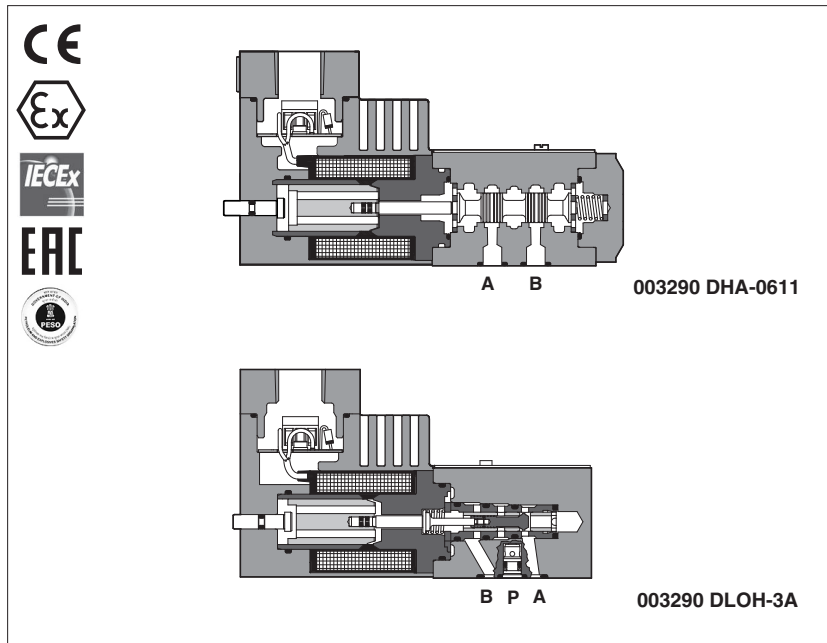

On/off directional and leak-free valves equipped with explosion-proof solenoids provided with internal suppressor diode which eliminates the electric disturbances at the valve de-energizing.

Certifications:

• **Multicertification** ATEX, IECEx and EAC for gas group **II 2G** and dust category **II 2D**  
DHA valves are **SIL** compliance with IEC 61508 (TÜV certified)

The flameproof solenoid enclosure prevents the propagation of accidental internal sparks or fire to the external environment.

The solenoid is also designed to limit its surface temperature within the classified limits.

**1 DHA MODEL CODE**

<b>003290</b>	<b>DHA</b>	-	<b>0</b>	<b>63</b>	<b>1/2</b>	/	<b>M</b>	/	<b>*</b>	<b>24DC</b>	/	<b>**</b>	/	<b>*</b>
Special execution with internal suppressor diode														Seals material, see section 8: - = NBR <b>PE</b> = FKM <b>BT</b> = HNBR
Spool type - direct valve Ex-proof Multicertification ATEX, IECEx, EAC: Group II 2G / II 2D														Series number
<b>Valve size</b> (ISO 4401) <b>0</b> = 06														
<b>Configuration</b> , see section 2														
<b>Spool type</b> , see section 2														
<b>Solenoid threaded connection</b> for cable gland fitting: <b>GK</b> = GK-1/2" <b>M</b> = M20x1,5 - not for cULus <b>NPT</b> = 1/2" NPT														
														<b>Voltage code</b> - see section 7

**Options:**

- A** = solenoid at side of port B (for single solenoid valves)
- O** = horizontal cable entrance
- WP** =  manual override protected by metallic cap
- Hand lever options (2):**
- MV** = vertical hand lever
- AMV** = vertical hand lever installed at side of port B

- (1) The valves with Multicertification for Group II are also certified according to Indian petroleum and Explosion Safety Certification **PESO**. The PESO certificate can be downloaded from [www.atos.com](http://www.atos.com), catalog on line, **technical information** section
- (2) Options MV and AMV are available only for configuration **61, 61/A, 63, 63/A, 71** and with spool type **0, 0/2, 1, 1P, 1/2, 1/2P, 3, 3P, 4, 7**. Not available in combination with option **WP**

**2 DHA CONFIGURATIONS and SPOOLS**

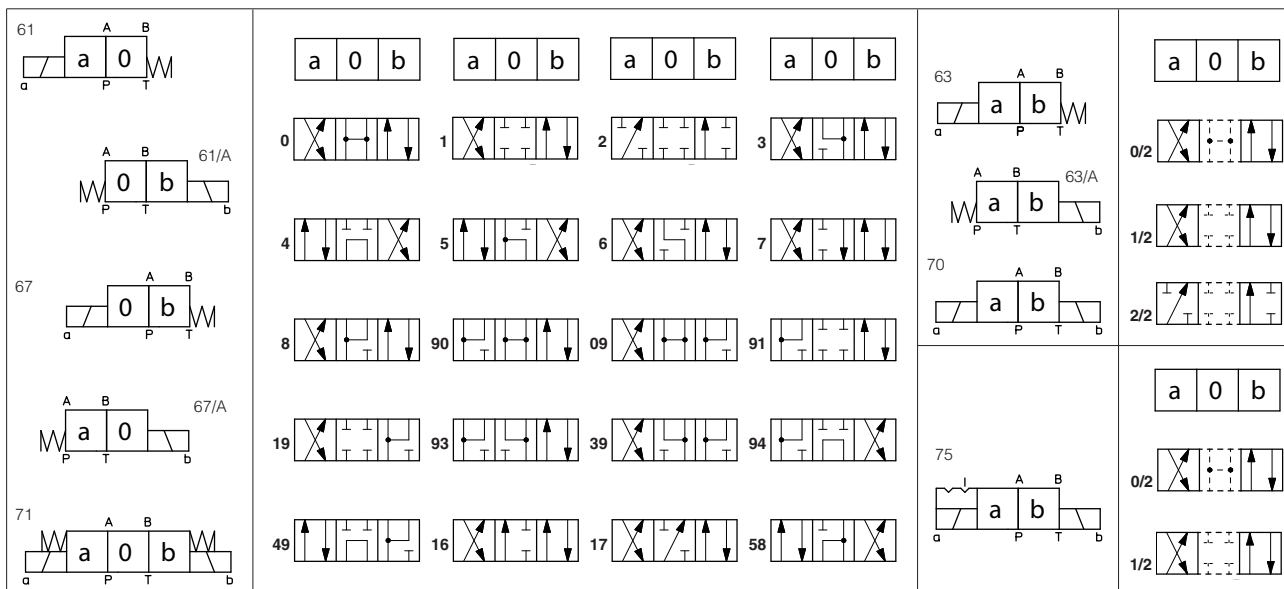

For spool type 2 and 2/2 port T of the valve must be connected to tank if the operating pressure exceed the max T pressure reported at section 4 (1): not available for configuration 75

**2.1 Special shaped spools**

- spools type **0** and **3** are also available as **0/1** and **3/1** with restricted oil passages in central position, from user ports to tank.
- spools type **1, 4, 5** and **58** are also available as **1/1, 4/8, 5/1** and **58/1**. They are properly shaped to reduce water-hammer shocks during the switching.
- spools type **1, 1/2, 3, 8** are available as **1P, 1/2P, 3P, 8P** to limit valve internal leakages.

**3 DLAH\* and CART-DLAH\* MODEL CODE**

<p><b>003290</b></p> <p>Special execution with internal suppressor diode</p> <p>Poppet type - direct valve Ex-proof Multicertification ATEX, IECEX, EAC (1): Group II 2G / II 2D ISO 06 subplate version <b>DLAH</b> = max flow 12 l/min <b>DLAHM</b> = max flow 30 l/min</p> <p><b>2</b> = two way (only for DLAH) <b>3</b> = three way</p> <p><b>Configuration</b> see section 4 <b>A C</b></p>	<p><b>DLAH</b> - <b>2</b></p>	<p><b>A</b> / <b>M</b> / <b>*</b></p>	<p><b>24DC</b> / <b>**</b> / <b>*</b></p> <p>Series number</p> <p>Seals material, see section 8: - = NBR <b>PE</b> = FKM <b>BT</b> = HNBR</p> <p><b>Voltage code</b> - see section 7</p> <p><b>Options:</b> <b>O</b> = horizontal cable entrance <b>R</b> = with check valve on port P (only for DLAH) <b>WP</b> =  manual override protected by metallic cap</p> <p><b>Solenoid threaded connection</b> for cable gland fitting: <b>GK</b> = GK-1/2" <b>M</b> = M20x1,5 <b>NPT</b> = 1/2" NPT</p>
---	-------------------------------	---------------------------------------	--

(1) The valves with Multicertification for Group II are also certified according to Indian petroleum and Explosion Safety Certification **PESO**. The PESO certificate can be downloaded from [www.atos.com](http://www.atos.com) - catalog on line, **technical information** section

The pressure at T port makes difficult the manual override operation that can be possible only if its value is lower than 50 bar.

**4 DLAH\* CONFIGURATIONS AND HYDRAULIC SYMBOLS** (representation according to ISO 1219-1)

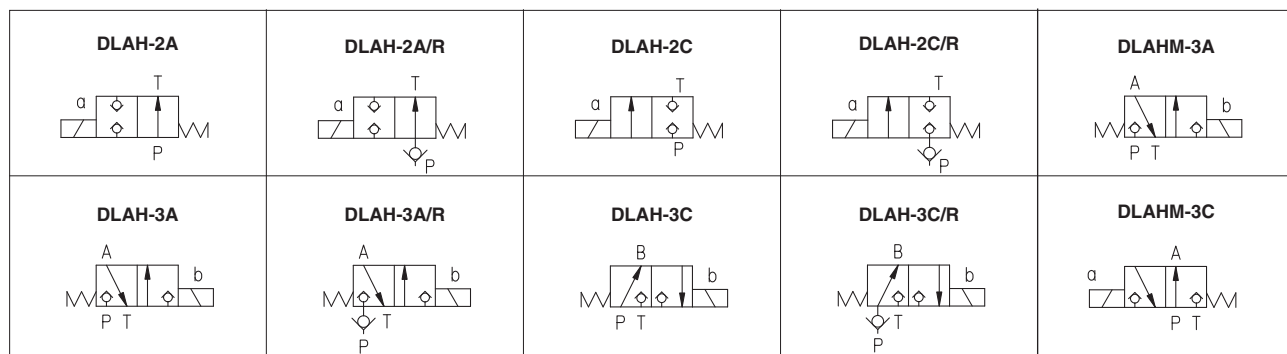

## 5 GENERAL CHARACTERISTICS

Assembly position / location	Any position
Subplate surface finishing	Roughness index Ra 0,4 - flatness ratio 0,01/100 (ISO 1101)
MTTFd values according to EN ISO 13849	150 years, for further details see technical table P007
Ambient temperature	<b>Standard</b> = -20°C ÷ +70°C <b>/PE</b> option = -20°C ÷ +70°C <b>/BT</b> option = -40°C ÷ +70°C
Storage temperature range	<b>Standard</b> = -20°C ÷ +80°C <b>/PE</b> option = -20°C ÷ +80°C <b>/BT</b> option = -40°C ÷ +70°C
Surface protection	Zinc coating with black passivation (body and solenoid housing)
Compliance	Explosion proof protection, see section 9

## 6 HYDRAULIC CHARACTERISTICS

Operating pressure	Ports P,A,B: DHA, DLAH, <b>350 bar</b> ; DLAHM, ports P,A: <b>315 bar</b> Port T <b>210 bar</b>
Rated flow	See diagrams Q/Δp at section 13
Maximum flow	DHA = <b>70 l/min</b> , see operating limits at section 14 DLAH: <b>12 l/min</b> , DLAHM: <b>30 l/min</b> , see operating limits at section 12

## 7 ELECTRICAL CHARACTERISTICS

Valve type	DHA, DLAH, DLAHM,
Voltage code (1) $V_{DC} \pm 10\%$	<b>12DC, 24DC, 28DC, 48DC, 110DC, 125DC, 220DC</b>
$V_{AC} 50/60 \text{ Hz} \pm 10\%$	<b>12AC, 24AC, 110AC, 230AC</b>
Power consumption at 20°C	8W
Coil insulation	class H
Protection degree with relevant cable gland	IP66/67 to DIN EN60529
Duty factor	100%

(1) For alternating current supply a rectifier bridge is provided built-in the solenoid  
For power supply frequency 60 Hz, the nominal supply voltage of solenoids 110AC and 230AC must be 115/60 and 240/60 respectively

## 8 SEALS AND HYDRAULIC FLUIDS - for other fluids not included in below table, consult our technical office

Seals, recommended fluid temperature	NBR seals (standard) = -20°C ÷ +60°C, with HFC hydraulic fluids = -20°C ÷ +50°C FKM seals (/PE option) = -20°C ÷ +80°C HNBR seals (/BT option) = -40°C ÷ +60°C, with HFC hydraulic fluids = -40°C ÷ +50°C		
Recommended viscosity	15 ÷ 100 mm <sup>2</sup> /s - max allowed range 2.8 ÷ 500 mm <sup>2</sup> /s		
Fluid contamination class	ISO 4406 class 21/19/16 NAS 1638 class 10, in line filters of 25 μm (β <sub>25</sub> ≥ 75 recommended)		
<b>Hydraulic fluid</b>	<b>Suitable seals type</b>	<b>Classification</b>	<b>Ref. Standard</b>
Mineral oils	NBR, FKM, HNBR	HL, HLP, HLPD, HVLP, HVLPD	DIN 51524
Flame resistant without water	FKM	HFDU, HFDR	ISO 12922
Flame resistant with water	NBR, HNBR	HFC	

 The ignition temperature of the hydraulic fluid must be 50°C higher than the max solenoid surface temperature.

### (1) Performance limitations in case of flame resistant fluids with water:

- max operating pressure = 210 bar
- max fluid temperature = 50°C

**9 CERTIFICATION DATA**

Valve type	DHA, DLAH, DLAHM	
Certifications	Multicertification Group II <b>ATEX IECEx EAC</b>	
Solenoid certified code	<b>OA</b>	
Type examination certificate (1)	ATEX: CESI 02 ATEX 014 IECEX: IECEX CES 10.0010x EAC: TC RU C-IT. 08.B.01784	
Method of protection	<ul style="list-style-type: none"> <li>• ATEX 2014/34/EU Ex II 2G Ex d IIC T6/T4/T3 Gb Ex II 2D Ex tb IIIC T85°C/T200°C Db</li> <li>• IECEx Ex d IIC T6/T4/T3 Gb Ex tb IIIC T85°C/T200°C Db</li> <li>• EAC Ex II 2G Exd IIC T6/T4</li> </ul>	
Temperature class	<b>T6</b>	<b>T4</b>
Surface temperature	≤ 85 °C	≤ 135 °C
Ambient temperature (2)	-40 ÷ +45 °C	-40 ÷ +70 °C
Mechanical construction Flameproof housing enclosure Ex d	EN 60079-0: 2012, EN 60079-1: 2007 IEC 61508: 2010	
Cable entrance: threaded connection vertical (standard) or horizontal (option /O)	<b>GK</b> = GK-1/2" <b>M</b> = M20x1,5 <b>NPT</b> = 1/2" NPT	

(1) The type examiner certificates can be downloaded from [www.atos.com](http://www.atos.com), catalog on line, **technical information** section

(2) The solenoids **Group II** are certified for minimum ambient temperature -40°C.

In case the complete valve must withstand with minimum ambient temperature of -40°C, select **/BT** in the model code

**⚠ WARNING: service work performed on the valve by the end users or not qualified personnel invalidates the certification**

**10 EX PROOF SOLENOIDS WIRING**

**Standard version**

**Option /O**

① cover with threaded connection for vertical cable gland fitting  
 ② cover with threaded connection for horizontal cable gland fitting  
 ③ terminal board for cables wiring  
 ④ standard manual override  
 ⑤ screw terminal for additional equipotential grounding

0	1	1 = Coil
0	2	2 = GND
0	3	3 = Coil

PCB 3 poles terminal board  
suitable for wires cross sections  
up to 2,5 mm<sup>2</sup> (max AWG14)

**Electric scheme**

Dotted line = additional diodes for AC version

**11 CABLE SPECIFICATION AND TEMPERATURE** - Power supply and grounding cables have to comply with following characteristics:

<b>Multicertification Group II</b>	
<b>Power supply:</b> section of coil connection wires = 2,5 mm <sup>2</sup>	<b>Grounding:</b> section of internal ground wire = 2,5 mm <sup>2</sup> section of external ground wire = 4 mm <sup>2</sup>

**11.1 Cable temperature**

The cable must be suitable for the working temperature as specified in the "safety instructions" delivered with the first supply of the products.

**Multicertification**

Max ambient temperature [°C]	Temperature class Group II	Max surface temperature [°C] Group II	Min cable temperature
45 °C	T6	85 °C	not prescribed
70 °C	T4	135 °C	90 °C

**12 CABLE GLANDS only for Multicertification**

Cable glands with threaded connections GK-1/2", 1/2"NPT or M20x1,5 for standard or armoured cables have to be ordered separately, see tech. table **KX600**

**Note:** a Loctite sealant type 545, should be used on the cable gland entry threads

**13 Q/Δp DIAGRAMS OF ON/OFF DIRECTIONAL CONTROLS** (based on mineral oil ISO VG 46 at 50°C)

Flow direction Spool type	P→A	P→B	A→T	B→T	P→T
	<b>0</b>	C	C	C	C
<b>0/2, 1, 1/2</b>	A	A	A	A	
<b>3</b>	A	A	C	C	
<b>4, 5</b>	D	D	D	D	A
<b>6</b>	A	A	C	A	
<b>7</b>	A	A	A	C	
<b>8</b>	C	C	B	B	

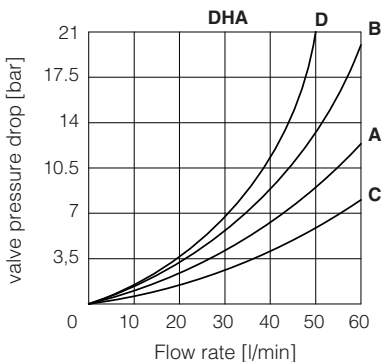

Flow direction Valve type	P → A (1) (P → B)	A → T (B → T)
	<b>DLAH-2A</b>	B
<b>DLAH-2C</b>	C	-
<b>DLAH-3A</b>	D	C
<b>DLAH-3C</b>	C	A
<b>DLAHM-3A</b>	F	E
<b>DLAHM-3C</b>	F	E

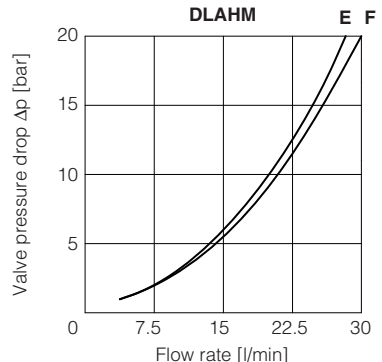
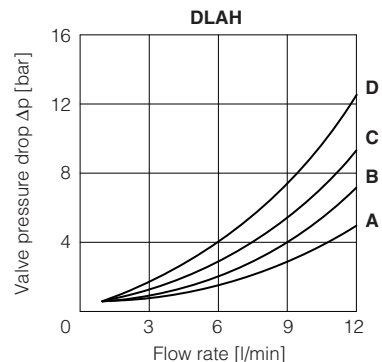

(1) For two-way valves, pressure drop refers to P→T

**14 OPERATING LIMITS OF ON/OFF DIRECTIONAL CONTROLS** (based on mineral oil ISO VG 46 at 50°C)

The diagram have been obtained with warm solenoids and power supply at lowest value (V<sub>nom</sub>-10%). For DHA valves the curves refer to application with symmetrical flow through the valve (i.e. P → A and B → T). In case of asymmetric flow the operating limits must be reduced.

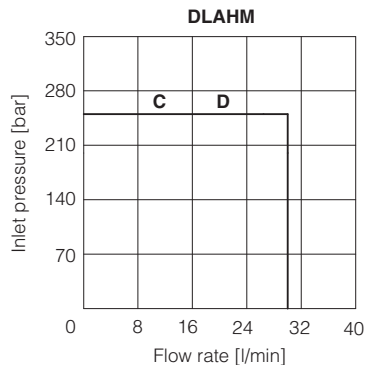
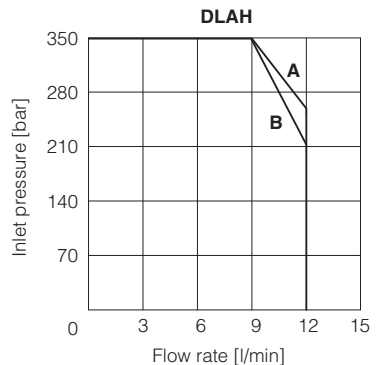
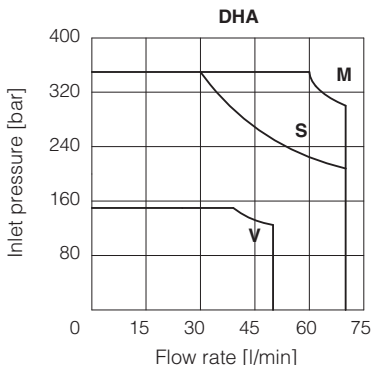

**M** = Spools 0, 1, 8;  
**S** = Spools 0/2, 1/2, 3, 6, 7;  
**V** = Spools 4, 5

**A** = DLAH-3A;  
**B** = DLAH-2A,  
DLAH-3C

**C** = DLAHM-3A;  
**D** = DLAHM-3C

**003290 DHA**

ISO 4401: 2005

Mounting surface: 4401-03-02-0-05

Fastening bolts:

4 socket head screws M5x50 class 12.9

Tightening torque = 8 Nm

Seals: 4 OR 108

Ports P,A,B,T:  $\varnothing = 7.5$  mm (max).

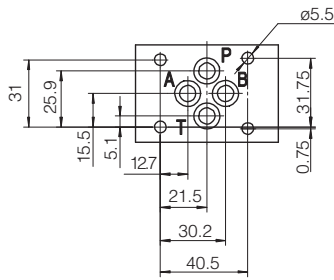

**P** = PRESSURE PORT  
**A, B** = USE PORT  
**T** = TANK PORT

**003290 DHA-06\***

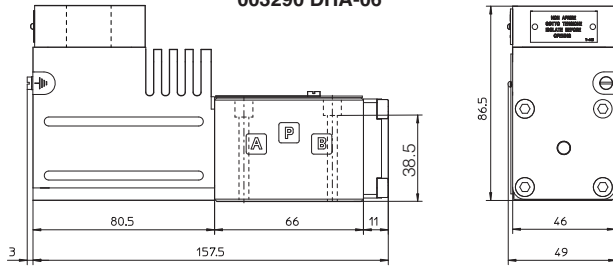

**003290 DHA-06\*/A**

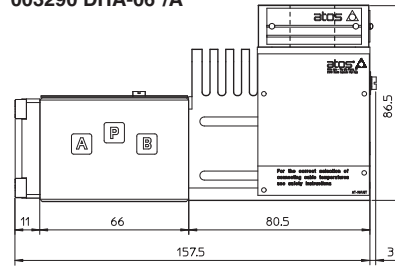

**003290 DHA-07\***

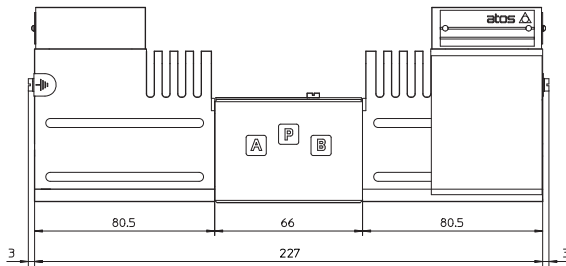

**003290 DLAH-2\***

ISO 4401: 2005

Mounting surface: 4401-03-02-0-05

without A and B ports

Fastening bolts: 4 socket head screws

M5x50 class 12.9

Tightening torque = 8 Nm

Seals: 2 OR 108

Ports P, T:  $\varnothing = 7.5$  mm (max)

**P** = PRESSURE PORT

**T** = USE PORT

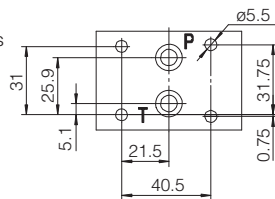

**003290 DLAH-3\***

ISO 4401: 2005

Mounting surface: 4401-03-02-0-05

Fastening bolts: 4 socket head screws:

M5X50 class 12.9

Tightening torque = 8 Nm

Seals: 4 OR 108

Ports P,A,B,T:  $\varnothing = 7.5$  mm (max)

**P** = PRESSURE PORT

**A** = USE PORT (not used for DLAH-3C version)

**B** = USE PORT (not used for DLAH-3A version)

**T** = TANK PORT

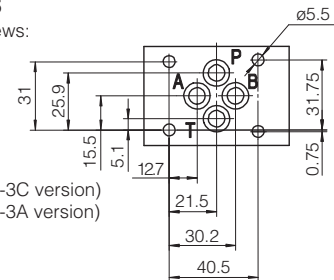

**003290 DLAH-2A, DLHA-2C**

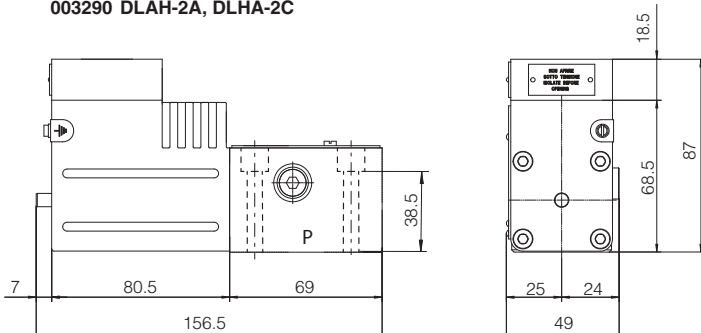

**003290 DLAH-3A**

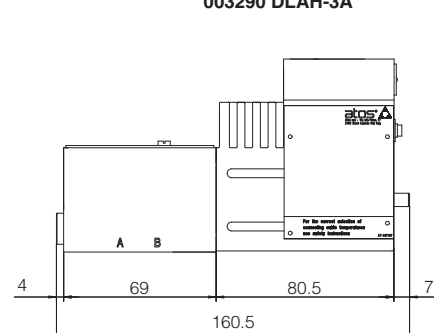

### 003290 DLAHM-3\*

ISO 4401: 2005

Mounting surface: 4401-03-02-0-05

Fastening bolts: 4 socket head screws:

M5X50 class 12.9

Tightening torque = 8 Nm

Seals: 4 OR 108

Ports P,A,B,T:  $\varnothing = 7.5$  mm (max)

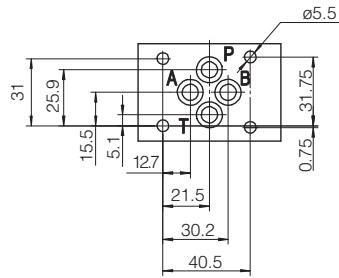

- P = PRESSURE PORT
- A = USE PORT
- B = not used
- T = TANK PORT

### 003290 DLAHM-3C

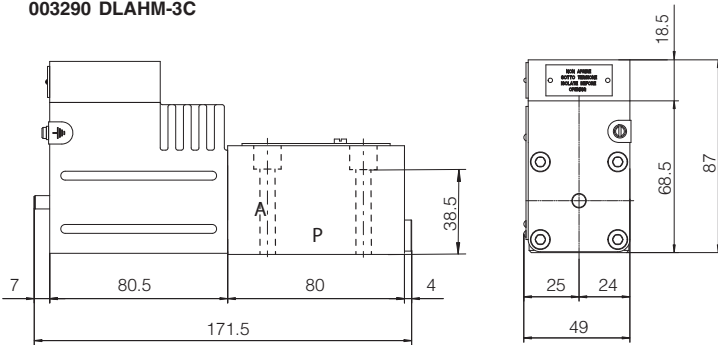

### 003290 DLAHM-3A

