

Multistage vacuum generator G3/8"

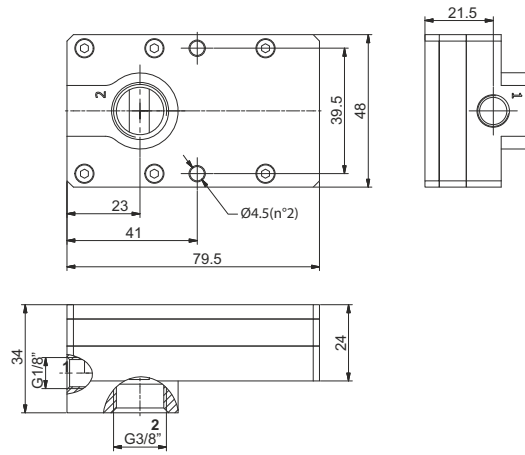

Ordering code
19M38.M.15.SS.00

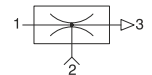

Compact generators comprising a number of modules as a function of the desired performance allow high-suction capacity with low consumption and other degrees of vacuum; as a function of the modules (nozzles 2-4-6-8) used, offer exactly the right performance for the most varied of industrial applications. They ensure a low level of noise thanks to the sound-absorbent material inside of them.

Performance characteristics

- Supply pressure (bar)	2	4	6
- Degree of Vacuum (-kPa)	40	86	83
- Intake flow rate (l/min)	90	131	140
- Air consumption (l/min)	57	94	133

Performance Charts

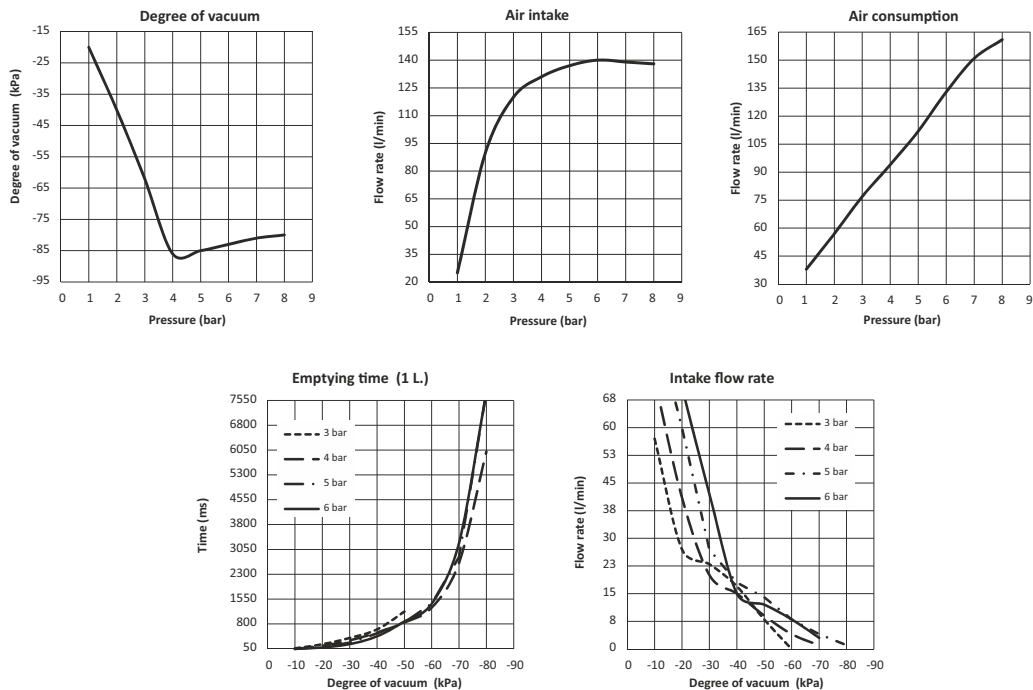

Technical features

Fluid	Unlubricated filtered air
Pressure (bar)	1 ÷ 8
Temperature (°C)	-10 ÷ +80
Weight (gr.)	178