

# Standard hydraulic power packs type ASH

vertical motor, submersed pump - reservoir capacity 10, 25, 50 and 100 liters

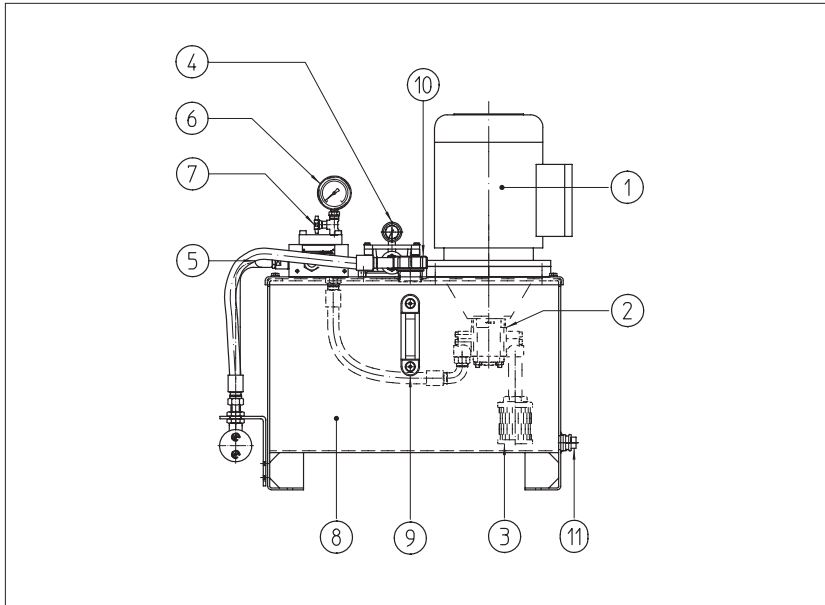

ASH hydraulic power packs are compact design standard units made according to machinery directive 2006/42/CE with vertical motor pump unit.

Electric motors and pumps are available in different variants, modular subplates type BA-243/A, to realize customized hydraulic circuits with modular and directional valves (ISO 4401 size 06), can be assembled on the cover.

Basic version is composed by:

- ① electric motor coupled with hydraulic pump ②;
- ③ suction submersed filter;
- ④ return filter with visual clogging indicator;
- ⑤ pressure relief valve;
- ⑥ glycerine filled pressure gauge Ø 60 with shut-off valve ⑦;
- ⑧ reservoir with visual oil level ⑨, filling plug with air filter ⑩ and emptying ⑪.

## 1 MODEL CODE

<b>ASH</b>	-	<b>25</b>	/	<b>G</b>	<b>142</b>	-	<b>1,1</b>	<b>S</b>	<b>/E</b>	<b>**</b>	
Type of hydraulic									Design number		
Reservoir capacity: 10 = 10 liters 25 = 25 liters 50 = 50 liters 100 = 100 liters									Options: /EA = air-oil heat exchanger, see section 3 /EW = water-oil heat exchanger, see section 3 /V = reservoir with oil collecting bottom lip. Options /EA and /EW are not available for ASH-10		
Type of pump: E = vane pump type PFE (see tab. A005) R = radial piston pump type PFR (see tab. A045) G = gear pump type PFG (see tab. A055)									Eventual suffix S = without electric motor		
Pump displacement, see section 4 for available combinations: for PFE                      for PFR                      for PFG									Electric power motor, see section 4		
31016 = 16,5 cm <sup>3</sup> /rev			202 = 1,7 cm <sup>3</sup> /rev			114 = 1,3 cm <sup>3</sup> /rev			187 = 9,1 cm <sup>3</sup> /rev		
31022 = 21,6 cm <sup>3</sup> /rev			203 = 3,7 cm <sup>3</sup> /rev			128 = 2,7 cm <sup>3</sup> /rev			199 = 10,8 cm <sup>3</sup> /rev		
31028 = 28,1 cm <sup>3</sup> /rev						142 = 4,1 cm <sup>3</sup> /rev			214 = 14 cm <sup>3</sup> /rev		
						160 = 6,1 cm <sup>3</sup> /rev			218 = 17,8 cm <sup>3</sup> /rev		
						174 = 7,4 cm <sup>3</sup> /rev			221 = 20,8 cm <sup>3</sup> /rev		
									Supply Voltages, see section 4.		
									0,4 = 0,37 kW                      3 = 3 kW		
									0,7 = 0,75 kW                      4 = 4 kW		
									1,1 = 1,1 kW                        5,5 = 5,5 kW		
									1,5 = 1,5 kW                        7,5 = 7,5 kW		
									2,2 = 2,2 kW		

## 2 HYDRAULIC SKETCHES

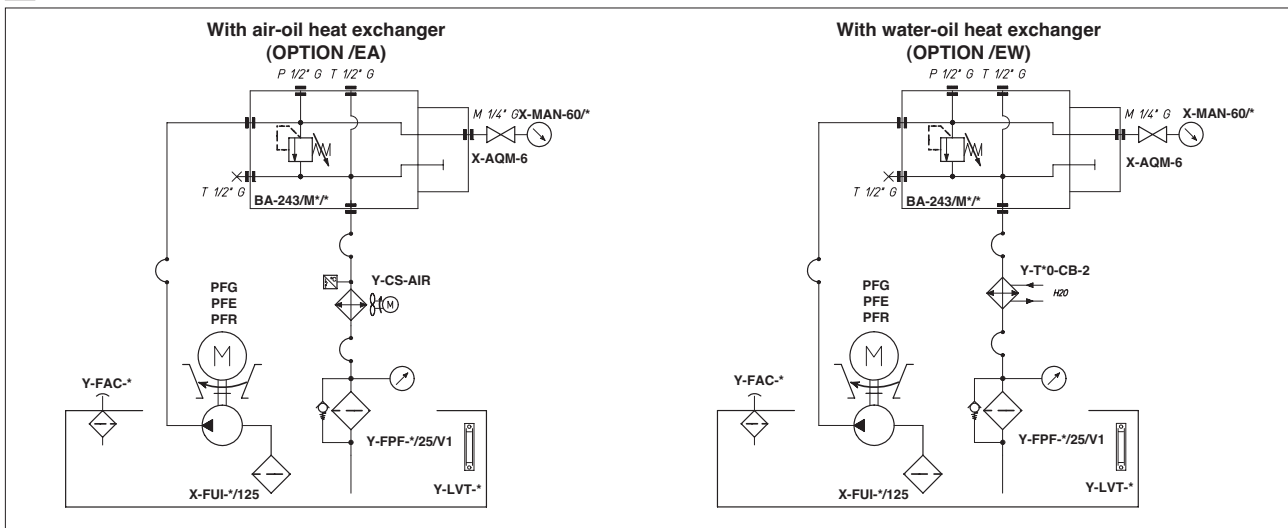

NOTE: on ASH-10 the oil filter on return line is not included and the optional mounting of heat exchanger is not available.

### 3 MAIN CHARACTERISTICS

Installation position	Horizontal: electric motor with vertical axis.
Ports	Ports P = G 1/2" on subplate BA-243/MP/** Ports T = G 1/2" on subplate BA-243/MP/**
Customized circuits	Customized circuits can be easily realized by means of modular plates type BA-243/A, molar valves size ISO 4401 size 06, solenoid valves and directional valves type DH*. In particular: <ul style="list-style-type: none"> <li>intermediate plates type BA-243/A must be assembled between the basic plate BA-243/M* and the closing element BA-243/T, mounted on the cover of the power packs;</li> <li>modular control valves type HMP, HM, HS, HG, HC, HQ, HR, solenoid valves and direction valves type DH* can be mounted on these intermediate plates according to the requested hydraulic sketch.</li> </ul>
Fluid	Hydraulic oil as per DIN 51524...535; for other fluids contact our technical office
Recommended viscosity	15 ÷ 100 mm <sup>2</sup> /s at 40°C (ISO VG 15 ÷ 100)
Fluid contamination class	ISO 19/16, achieved with in line filters at 25 µm and β <sub>25</sub> ≥ 75 (recommended)
Fluid temperature	-20°C +60°C (standard and /WG seals) -20°C +80°C (/PE seals) On request, water-oil (option /EW) or air-oil (option /EW) heat exchangers are available, connected as indicated on section 2. Air-oil exchanger are equipped with electroimpellers supplied at 230/400 V - 50/60 Hz. On power packs type ASH-10 the heat exchangers is not available.
Ambient temperature	From -20°C to + 70°C

Note: On the SSH-10 -HPU- the return filter is not present and assembly of heat exchangers is not expected.

### 4 HYDRAULIC CHARACTERISTICS

Model	Pump type	Flow rate at 1450 rpm and 7 bar [l/min]	Maximum pressure [bar] with motor's power:									Capacity of reservoir [liters]
			0,37 kW UNEL size 71 (1)	0,75 kW UNEL size 80 (1)	1,1 kW UNEL size 90 (1)	1,5 kW UNEL size 90 (1)	2,2 kW UNEL size 100 (1)	3 kW UNEL size 100 (1)	4 kW UNEL size 112 (1)	5,5 kW UNEL size 132 (1)	7,5 kW UNEL size 132 (1)	
Motor Mass[Kg]	-	-	7,5	9	13,5	14	23	23	30	41	52	-
ASH-10/G114	PFG-114	2,1	80 (4)	-	-	-	-	-	-	-	-	10
ASH-10/G128	PFG-128	4,2	45 (3)	-	-	-	-	-	-	-	-	25
ASH-25/G114	PFG-114	2,1	-	160 (5)	-	-	-	-	-	-	-	
ASH-25/G128	PFG-128	4,2	-	90 (4)	130 (4)	180 (5)	-	-	-	-	-	
ASH-25/G142	PFG-142	6,3	-	60 (3)	90 (4)	120 (4)	-	-	-	-	-	
ASH-25/G160	PFG-160	9	-	40 (3)	60 (3)	80 (4)	-	-	-	-	-	
ASH-25/G174	PFG-174	11	-	30 (3)	50 (3)	65 (3)	-	-	-	-	-	
ASH-50/R202	PFR-202	2,4	-	-	-	-	350 (6)	-	-	-	-	50
ASH-50/R203	PFR-203	5	-	-	-	-	250 (6)	320 (6)	350 (6)	-	-	
ASH-50/G160	PFG-160	8,5	-	-	-	-	120 (4)	170 (5)	-	-	-	
ASH-50/G174	PFG-174	10,5	-	-	-	-	100 (4)	130 (5)	-	-	-	
ASH-50/G187	PFG-187	13	-	-	-	-	80 (4)	110 (4)	150 (5)	-	-	
ASH-50/G199	PFG-199	15,2	-	-	-	-	70 (3)	90 (4)	120 (4)	-	-	
ASH-100/G214	PFG-214	19,5	-	-	-	-	-	-	-	130 (4)	180 (5)	100
ASH-100/G218	PFG-218	24,6	-	-	-	-	-	-	-	100 (4)	130 (5)	
ASH-100/G221	PFG-221	29	-	-	-	-	-	-	-	90 (4)	120 (4)	
ASH-100/E016	PFE-31016	23	-	-	-	-	-	-	-	120 (5)	170 (5)	
ASH-100/E022	PFE-31022	30	-	-	-	-	-	-	-	90 (4)	125 (5)	
ASH-100/E028	PFE-31028	40	-	-	-	-	-	-	-	70 (3)	95 (4)	

(1) Electric motor is: three phases, 4 poles, V 220/380 - 50/60 Hz (other voltages available on request), closed and ventilated, construction shape V1.

(2) Electric motor is: three phases, 4 poles, V 400/660 - 50/60 Hz (other voltages available on request), closed and ventilated, construction shape V1.

(3) Pressure relief valves type BA-243/MP/75 and manometers type X-MAN-60/100.

(4) Pressure relief valves type BA-243/MP/150 and manometers type X-MAN-60/250.

(5) Pressure relief valves type BA-243/MP/250 and manometers type X-MAN-60/250.

(6) Pressure relief valves type BA-243/M/350 and manometers type X-MAN-60/400.

### 5 MAIN COMPONENTS

Model	UNEL size of electric motor	Coupling	Bell housing	Suction filter	Return filter	Cartridge of return filter	Filling cap	Air-oil heat exchanger (option /EA)	Water-oil heat exchanger (option /EW)
ASH-10/G	71	Y-GA-11	Y-LMC1G1	X-FUI-25/125	-	-	Y-FAC-30	-	-
ASH-25/G	80	Y-GA-21	Y-LMC2G1	X-FUI-25/125	Y-FPF-030/25/V1	SP-PF-030/A25	Y-FAC-70	Y-CS-AIR-2010K/380	Y-T60-CB-2
ASH-25/G	90	Y-GA-41							
ASH-50/R	100	Y-GB-82/** (7)	Y-LS4P2	-	Y-FPF-100/25/V1	SP-PF-100/A25	Y-FAC-70	Y-CS-AIR-2020K/380	
ASH-50/R	112								
ASH-50/G	100	Y-GA-61	Y-LMC4G1	X-FUI-40/125	-	-	-	-	
ASH-50/G	112								
ASH-100/G	132	Y-GA-122	Y-LMC6G2	X-FUI-100/125	Y-FPF-102/25/V1	SP-PF-102/A25	Y-FAC-70	Y-CS-AIR-2020K/380	Y-T80-CB-2
ASH-100/E	132	Y-GA-09V31	Y-LMC6V3	X-FUI-100/125	Y-FPF-102/25/V1	SP-PF-102/A25	Y-FAC-70	Y-CS-AIR-2020K/380	Y-T80-CB-2

(7) The code must be completed with the pump displacement.

6 DIMENSIONS [mm]

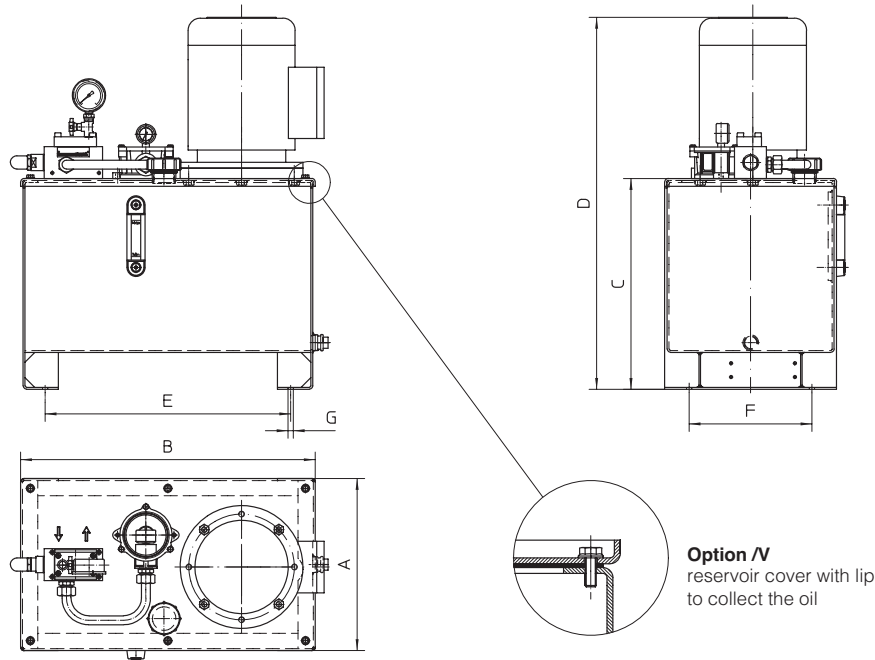

Model	A	B	C		D (max) (1)	E	F	G buttonholes	Mass (2) [kg]
			STD	OPT. /V					
ASH-10	200	400	245	260	480	300	100	21x11	12
ASH-25	300	500	325	340	600	400	200	21x11	24
ASH-50	350	600	430	445	800	500	250	21x11	43
ASH-100	500	750	480	495	950	630	380	21x11	90

**Option /EW**  
With water-oil heat exchanger

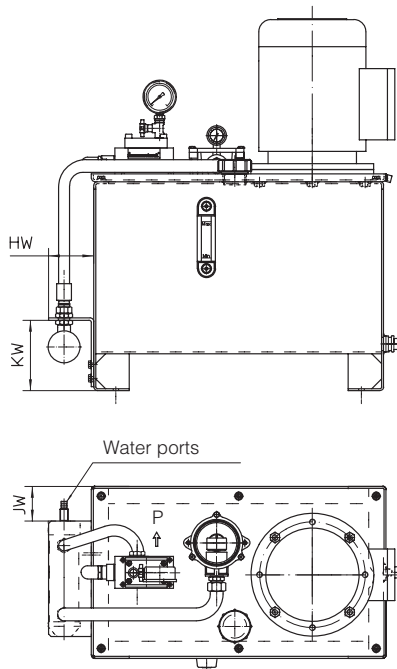

**Option /EA**  
With air-oil heat exchanger

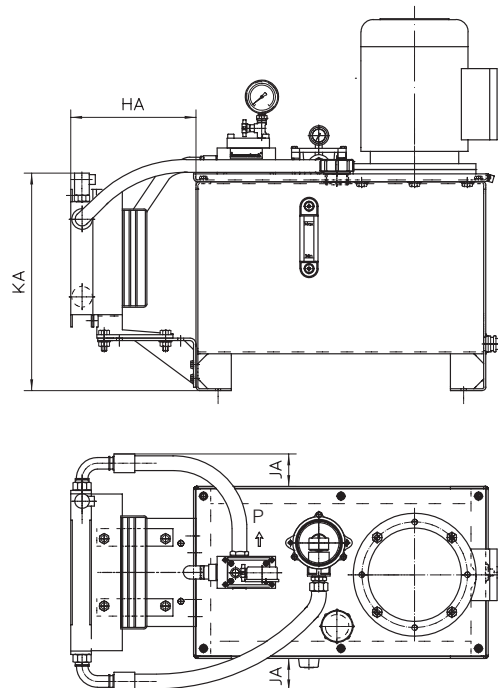

Model	HW	KW	JW	Mass (2) [kg]	Model	HA	KA	JA	Mass (2) [kg]
ASH-25/EW	92	143	20	26,5	ASH-25/EA	275	390	45	32,5
ASH-50/EW	92	143	70	45,5	ASH-50/EA	255	445	65	55
ASH-100/EW	112	143	50	92,5	ASH-100/EA	272	440	0	105

(1) The dimension refers to the assembly with the standard electric motor of the bigger available size (see section 4)  
 (2) The mass refers to the unit without electric motor and without oil.