



CD1-W

DIRECT OPERATED PRESSURE CONTROL VALVE SERIES 10

THREADED PORTS

p max 350 bar
Q max 3 l/min

HYDRAULIC SYMBOL

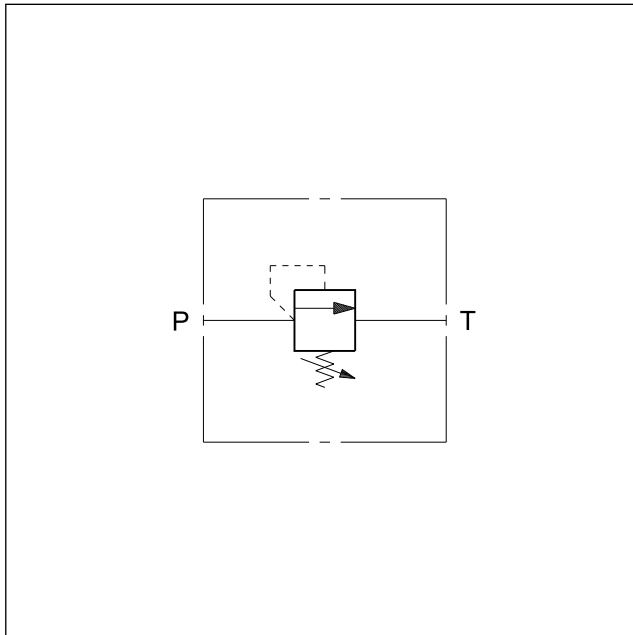

OPERATING PRINCIPLE

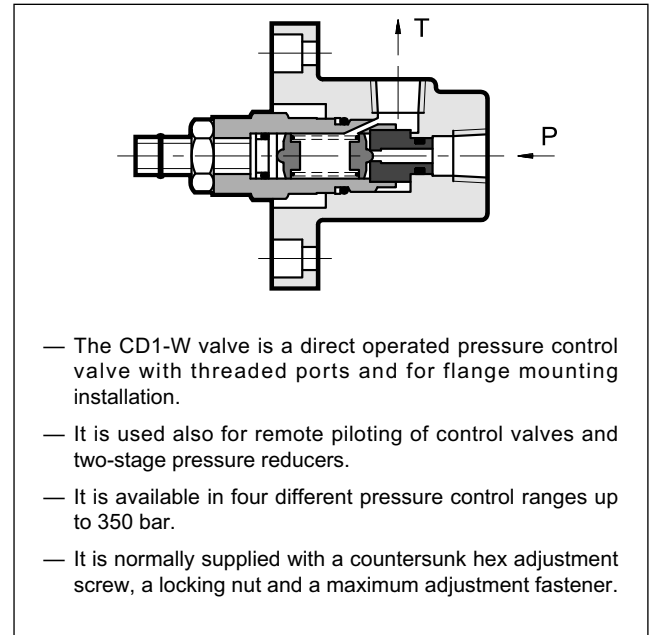

PERFORMANCE RATINGS (measured with mineral oil of viscosity 36 cSt at 50°C)

Maximum operating pressure	bar	350
Minimum controlled pressure	see diagram	
Maximum flow rate	l/min	3
Ambient temperature range	°C	-20 / +60
Fluid temperature range	°C	-20 / +80
Fluid viscosity range	cSt	10 + 400
Recommended filtration	according to ISO 4406:1999 class 20/18/15	
Recommended viscosity	cSt	25
Mass	kg	1,2

1 - IDENTIFICATION CODE

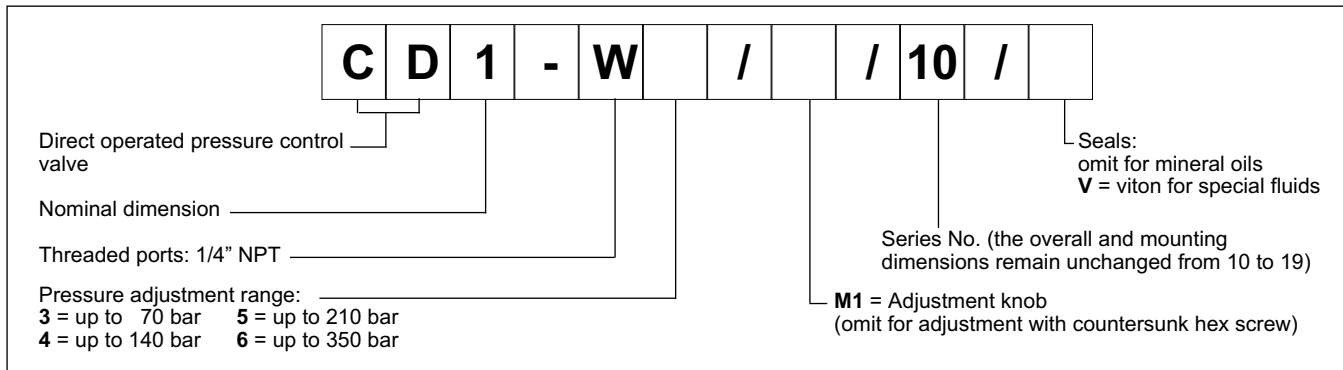

2 - CHARACTERISTIC CURVES (values obtained with viscosity of 36 cSt at 50°C)

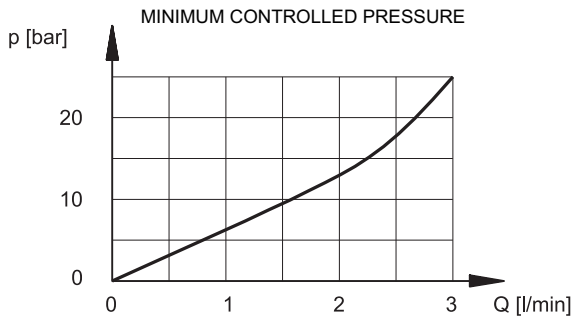
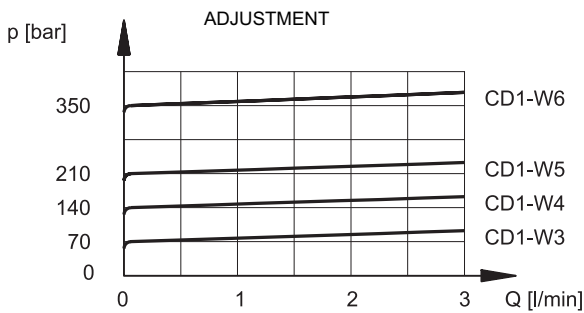

3 - HYDRAULIC FLUIDS

Use mineral oil-based hydraulic fluids HL or HM type, according to ISO 6743-4. For these fluids, use NBR seals. For fluids HFDR type (phosphate esters) use FPM seals (code V). For the use of other kinds of fluid such as HFA, HFB, HFC, please consult our technical department. Using fluids at temperatures higher than 80 °C causes a faster degradation of the fluid and of the seals characteristics. The fluid must be preserved in its physical and chemical characteristics.

4 - OVERALL AND MOUNTING DIMENSIONS

