

# Digital servoactuators for PARISON controls

in blow molding machines

**Available only on request**

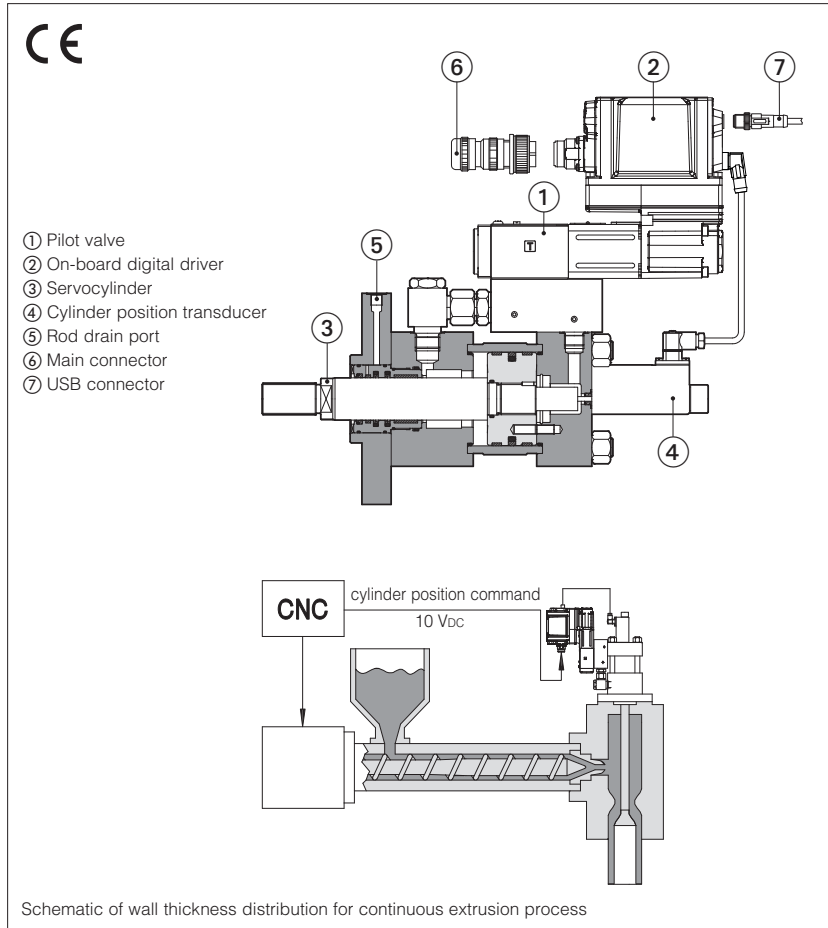

The Parison control is a well known process used in the plastic blow molding machines for the wall thickness distribution of continuous extruded profiles.

It is mainly used to obtain hollow items, as plastic bottles, tanks, etc, whose thickness can be modulated depending to the required localized mechanical resistance. The wall thickness is realized by means of a specific servoactuator operated in position closed loop control (see below the application scheme).

The Atos servoactuators CKZ are stand alone units performing closed loop position control.

The integral and compact execution ensures the best stiffness of the hydraulic system and it permits high dynamics and position accuracy.

The servoactuator is operated by means of analog commands sent to the 7 or 12 pins main connector.

The command signal 0 ÷ 10 V<sub>dc</sub> defines the servocylinder rod position in the stroke range 0 ÷ 12 mm.

**Available cylinder sizes:**

ø 63/28, ø 80/36, ø 100/45, ø 125/45,  
ø 160/70, ø 200/90 mm

**Stroke:**

12 mm

**1 MODEL CODE**

<b>061810</b>	<b>CKZ</b>	-	<b>SN</b>	-	<b>NP</b>	-	<b>1</b>		<b>0</b>	-	<b>80/36</b>	*	<b>0012</b>	-	<b>A</b>	<b>GP</b>	/	*	/	*	
Design number	Digital electrohydraulic servoactuator for linear axis position control		Alternated P/Q controls: SN = none		Fieldbus interfaces, USB port always present: NP = Not present		Valve size: 1 = size 06 (only for cylinder size 63/28, 80/36, 100/45) 2 = size 10 (only for cylinder size 160/70, 200/90)				Bore diameter / Rod diameter [mm]: 63/28 80/36 100/45 125/45 160/70 200/90		Stroke: 0012 = 12 mm			Parison control					Front flange attachment
																					<b>Rod position vs. position signal:</b> - = fully in at 0 V <sub>dc</sub> B = fully out at 0 V <sub>dc</sub>  <b>Main connector:</b> - = 7 pin Z = 12 pin

## 2 SERVOACTUATOR COMPOSITION

The digital servoactuator is composed by:

- Special cylinder equipped with low friction seals and with LVDT position transducer.
- High dynamic servoproportional valve with zero spool overlap in sleeve execution and LVDT position transducer
- Digital driver with integral axis controller. The USB communication interface permits to optimize the application's performances, modifying via software, the internal parameters by means of the relevant programming device E-SW to be used with standard PC

Servoactuator model code	Servocylinder code	Servoproportional pilot valve code (see tab. FS180)
061810 CKZ-SN-NP-10-63/28*0012-A/GP	07K0323 CKT/10-9-63/28*0012-A002-L-B1X1	051321 DLHZO-LES-SN-NP-040-L51/B
061810 CKZ-SN-NP-10-80/36*0012-A/GP	02K1260 CKT/10-9-80/36*0012-A002-L-B1X1	
061810 CKZ-SN-NP-10-100/45*0012-A/GP	06K0120 CKT/10-9-100/45*0012-A002-L-B1X1	
061810 CKZ-SN-NP-10-125/45*0012-A/GP	06K0123 CKT/10-9-125/45*0012-A002-L-B1X1	
061810 CKZ-SN-NP-10-160/70*0012-A/GP	06K0219 CKT/20-9-160/70*0012-A002-L-B1X1	061288 DLKZOR-LES-SN-NP-140-L31/B
061810 CKZ-SN-NP-10-200/90*0012-A/GP	08K0125 CKT/20-9-200/90*0012-A002-L-B1X1	

## 3 MAIN CHARACTERISTICS

Bore diameter	[mm]	63	80	100	125	160	200
Rod diameter	[mm]	28	36	45	45	70	90
Working stroke	[mm]	12					
Max pressure	[bar]	160					
Max force (kN)	Pull	40	64	100	170	260	400
	Push	50	80	125	190	320	500
Max speed	[m/s]	0,5					
Command signal	[VDC]	0 ÷ 10 (OV = rod fully in: standard) (OV = rod fully out: option /B)					
Linearity		0,03 %					
Response time at step signal (0-100%)	[ms]	85	115	300	320	300	

## 4 POWER SUPPLY AND SIGNALS SPECIFICATIONS

Generic electrical output signals of the valve (e.g. fault or monitor signals) must not be directly used to activate safety functions, like to switch-ON/OFF the machine's safety components, as prescribed by the European standards (Safety requirements of fluid technology systems and components-hydraulics, EN-982).

### 4.1 Power supply (V+ and V0)

The power supply must be appropriately stabilized or rectified and filtered: apply at least a 10000 F/40 V capacitance to single phase rectifiers or a 4700 F/40 V capacitance to three phase rectifiers. In case of separate power supply see 4.2.



A safety fuse is required in series to each power supply: 2,5 A time lag fuse.

### 4.2 Power supply for driver's logic and communication (VL+ and VL0) - only /Z option

The power supply for driver's logic and communication must be appropriately stabilized or rectified and filtered: apply at least a 10000 F/40 V capacitance to single phase rectifiers or a 4700 F/40 V capacitance to three phase rectifiers.

The separate power supply for driver's logic on pin 9 and 10, allow to remove solenoid power supply from pin 1 and 2 maintaining active the diagnostics, USB and fieldbus communications.



A safety fuse is required in series to each driver's logic and communication power supply: 500 mA fast fuse.

### 4.3 Position reference input signal (Q\_INPUT+)

The driver controls in closed loop the axis position proportionally to the external reference input signal.

Reference input signal is factory preset according to selected valve code, defaults are  $\pm 10$  VDC for standard and  $4 \div 20$  mA for /I option. Input signal can be reconfigured via software selecting between voltage and current, within a maximum range of  $\pm 10$  VDC or  $\pm 20$  mA.

### 4.4 Position monitor output signal (Q\_MONITOR)

The driver generates an analog output signal proportional to the actual axis position; the monitor output signal can be software set to show other signals available in the driver (e.g. analog reference, pilot spool position).

Monitor output signal is factory preset according to selected code, defaults are  $\pm 10$  VDC for standard and  $4 \div 20$  mA for /I option.

Output signal can be reconfigured via software selecting between voltage and current, within a maximum range of  $\pm 10$  VDC or  $\pm 20$  mA.

### 4.5 Enable input signal (ENABLE) - only /Z option

To enable the driver, supply a 24 VDC on pin 3: Enable input signal allows to enable/disable the current supply to the solenoid, without removing the electrical power supply to the driver; it is used to active the communication and the other driver functions when the valve must be disabled for safety reasons. This condition **does not comply** with norms IEC 61508 and ISO 13849.

Enable input signal can be used as generic digital input by software selection.

### 4.6 Fault output signal (FAULT) - only /Z option

Fault output signal indicates fault conditions of the driver (solenoid short circuits/not connected, reference signal cable broken for  $4 \div 20$  mA input, spool position transducer cable broken, etc.). Fault presence corresponds to 0 VDC, normal working corresponds to 24 VDC.

Fault status is not affected by the Enable input signal. Fault output signal can be used as digital output by software selection.

## 5 ELECTRONIC CONNECTIONS AND LEDS

### 5.1 Main connector signal - 7 pin (A1) Standard

PIN	Standard	TECHNICAL SPECIFICATIONS	NOTES
A	V+	Power supply 24 Vdc	Input - power supply
B	V0	Power supply 0 Vdc	Gnd - power supply
C	AGND	Analog ground	Gnd - analog signal
D	Q_INPUT+	Position reference input signal: $\pm 10$ Vdc / $\pm 20$ mA maximum range Defaults are $\pm 10$ Vdc for standard and $4 \div 20$ mA for /I option	Input - analog signal <b>Software selectable</b>
E	INPUT-	Negative reference input signal for Q_INPUT+	Input - analog signal
F	Q_MONITOR	Position monitor output signal: $\pm 10$ Vdc / $\pm 20$ mA maximum range, referred to VLO Defaults are $\pm 10$ Vdc for standard and $4 \div 20$ mA for /I option	Output - analog signal <b>Software selectable</b>
G	EARTH	Internally connected to driver housing	

### 5.2 Main connector - 12 pin (A2) /Z option

PIN	/Z	TECHNICAL SPECIFICATIONS	NOTES
1	V+	Power supply 24 Vdc	Input - power supply
2	V0	Power supply 0 Vdc	Gnd - power supply
3	ENABLE	Enable (24 Vdc) or disable (0 Vdc) the driver, referred to VLO	Input - on/off signal
4	Q_INPUT+	Position reference input signal: $\pm 10$ Vdc / $\pm 20$ mA maximum range Defaults are $\pm 10$ Vdc for standard and $4 \div 20$ mA for /I option	Input - analog signal <b>Software selectable</b>
5	INPUT-	Negative reference input signal for Q_INPUT+	Input - analog signal
6	Q_MONITOR	Position monitor output signal: $\pm 10$ Vdc / $\pm 20$ mA maximum range, referred to VLO Defaults are $\pm 10$ Vdc for standard and $4 \div 20$ mA for /I option	Output - analog signal <b>Software selectable</b>
7	NC	Do not connect	
8	NC	Do not connect	
9	VL+	Power supply 24 Vdc for driver's logic and communication	Input - power supply
10	VLO	Power supply 0 Vdc for driver's logic and communication	Gnd - power supply
11	FAULT	Fault (0 Vdc) or normal working (24 Vdc), referred to VLO	Output - on/off signal
PE	EARTH	Internally connected to driver housing	

**Note:** do not disconnect VLO before VL+ when the controller is connected to PC USB port

### 5.3 USB connector - M12 - 5 pin (B) always present

PIN	SIGNAL	TECHNICAL SPECIFICATION (1)
1	+5V_USB	Power supply
2	ID	Identification
3	GND_USB	Signal zero data line
4	D-	Data line -
5	D+	Data line +

(1) Shield connection on connector's housing is recommended

### 5.4 Connections layout

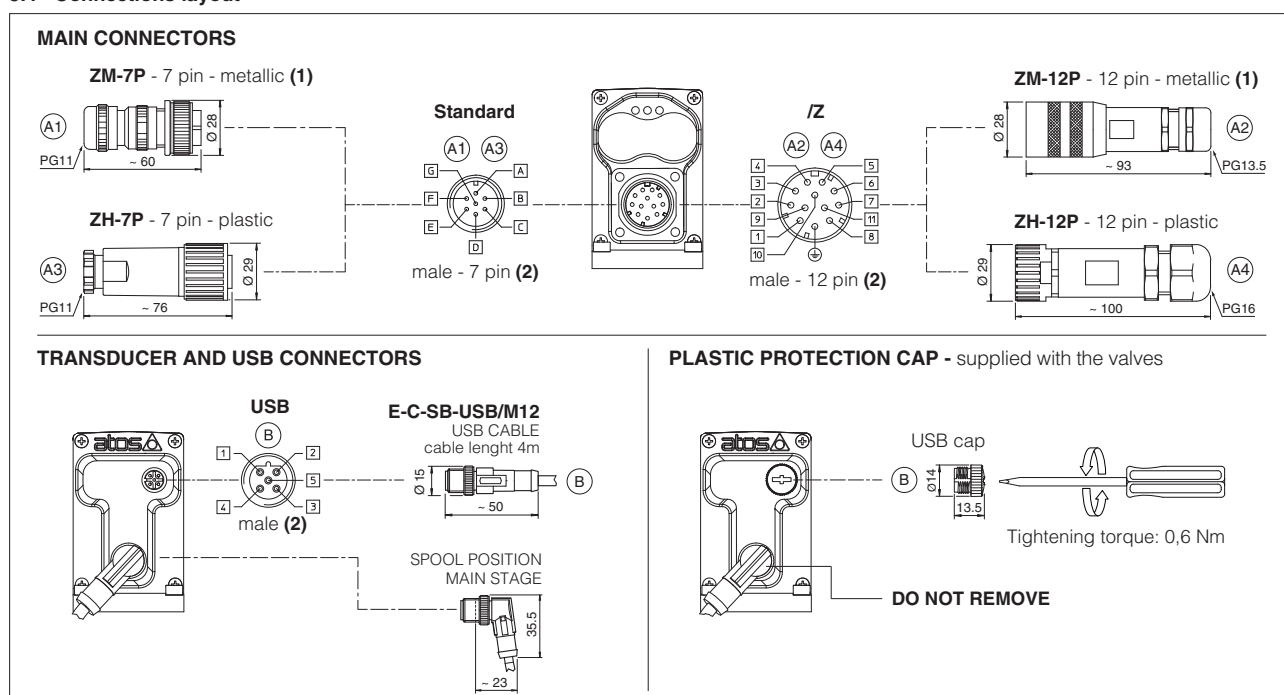

(1) Use of metallic connectors is strongly recommended in order to fulfill EMC requirements

(2) Pin layout always referred to driver's view

## 5.5 Diagnostic LEDs

Three leds show driver operative conditions for immediate basic diagnostics. Please refer to the driver user manual for detailed information.

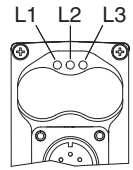
FIELDBUS LEDS	NP Not Present	L1 L2 L3
L1	VALVE STATUS	
L2	NETWORK STATUS	
L3	SOLENOID STATUS	

## 6 CONNECTORS CHARACTERISTICS - to be ordered separately

### 6.1 Main connectors - 7 pin - Standard

CONNECTOR TYPE	POWER SUPPLY	POWER SUPPLY
CODE	(A1) ZM-7P	(A3) ZH-7P
Type	7pin female straight circular	7pin female straight circular
Standard	According to MIL-C-5015	According to MIL-C-5015
Material	Metallic	Plastic reinforced with fiber glass
Cable gland	PG11	PG11
Recommended cable	LiYCY 7 x 0,75 mm <sup>2</sup> max 20 m (logic and power supply) or LiYCY 7 x 1 mm <sup>2</sup> max 40 m (logic and power supply)	LiYCY 7 x 0,75 mm <sup>2</sup> max 20 m (logic and power supply) or LiYCY 7 x 1 mm <sup>2</sup> max 40 m (logic and power supply)
Conductor size	up to 1 mm <sup>2</sup> - available for 7 wires	up to 1 mm <sup>2</sup> - available for 7 wires
Connection type	to solder	to solder
Protection (EN 60529)	IP 67	IP 67

### 6.2 Main connectors - 12 pin - /Z option

CONNECTOR TYPE	POWER SUPPLY	POWER SUPPLY
CODE	(A2) ZM-12P	(A4) ZH-12P
Type	12pin female straight circular	12pin female straight circular
Standard	DIN 43651	DIN 43651
Material	Metallic	Plastic reinforced with fiber glass
Cable gland	PG13,5	PG16
Recommended cable	LiYCY 12 x 0,75 mm <sup>2</sup> max 20 m (logic and power supply)	LiYCY 10 x 0,14mm <sup>2</sup> max 40 m (logic) LiYY 3 x 1mm <sup>2</sup> max 40 m (power supply)
Conductor size	0,5 mm <sup>2</sup> to 1,5 mm <sup>2</sup> - available for 12 wires	0,14 mm <sup>2</sup> to 0,5 mm <sup>2</sup> - available for 9 wires 0,5 mm <sup>2</sup> to 1,5 mm <sup>2</sup> - available for 3 wires
Connection type	to crimp	to crimp
Protection (EN 60529)	IP 67	IP 67

## 7 SERVOACTUATOR SETTINGS AND PROGRAMMING TOOLS - see table GS500

Servoactuator functional parameters and configurations, can be easily set and optimized using Atos **E-SW-BASIC** programming software connected via USB port to the digital driver (see table **GS003**).

**WARNING: drivers USB port is not isolated!** For E-C-SB-USB/M12 cable, the use of isolator adapter is highly recommended for PC protection

**WARNING: Bluetooth adapter is available only for European, USA and Canadian markets!**  
Bluetooth adapter is certified according RED (Europe), FCC (USA) and ISED (Canada) directives

### USB or Bluetooth connection

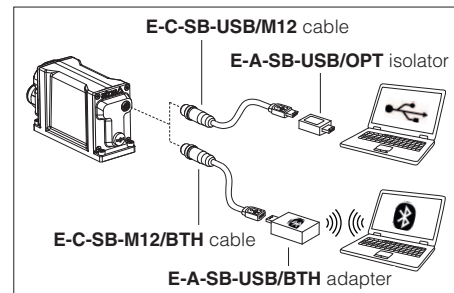

8 INSTALLATION DIMENSION [mm]

061810 CKZ-SN-NP-10-63/28\*0012-A/GP

P, T = 3/8"

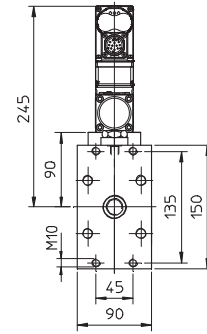
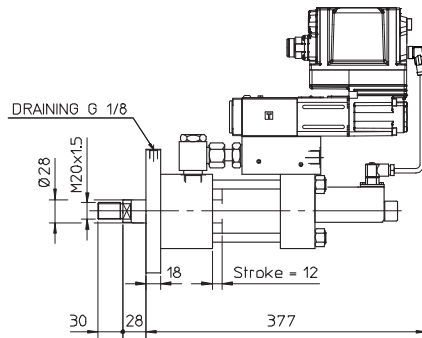
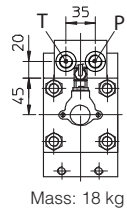

061810 CKZ-SN-NP-10-80/36\*0012-A/GP

P, T = 3/8"

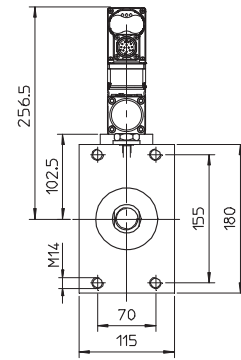
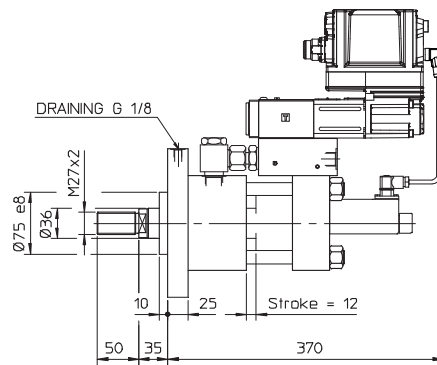
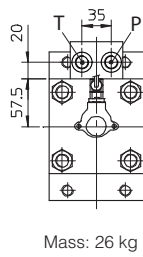

061810 CKZ-SN-NP-10-100/45\*0012-A/GP

P, T = 3/8"

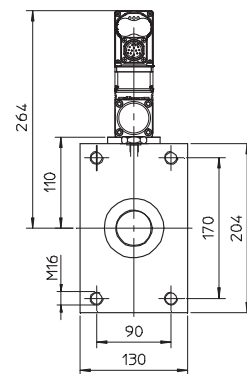
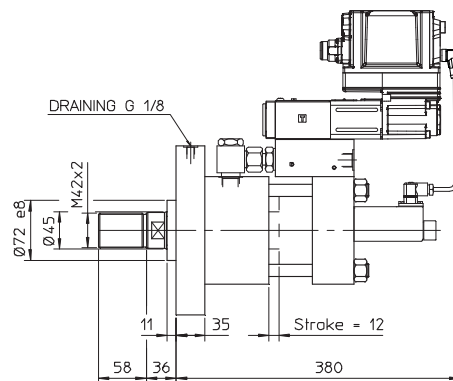
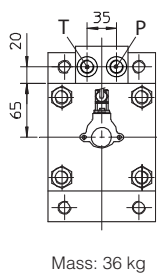

**061810 CKZ-SN-NP-10-125/45\*0012-A/GP**

**P, T = 3/8"**

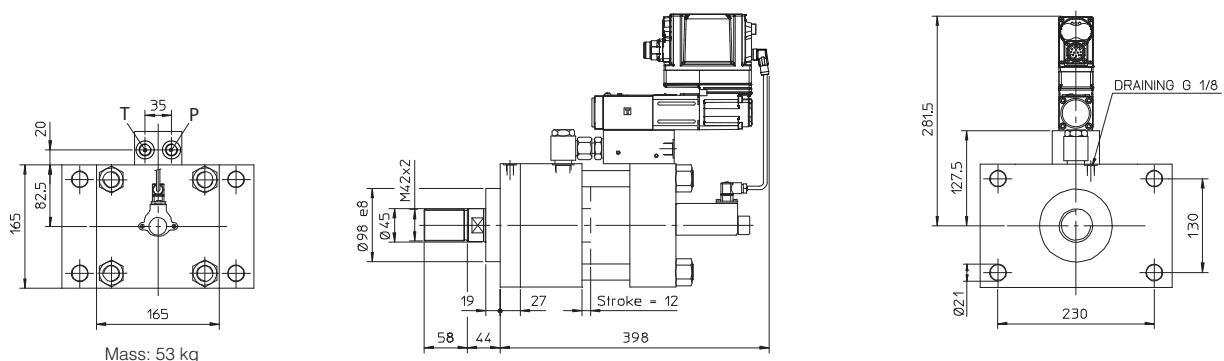

**061810 CKZ-SN-NP-10-160/70\*0012-A/GP**

**P, T = 3/4"**  
**X, Y = 1/4"**

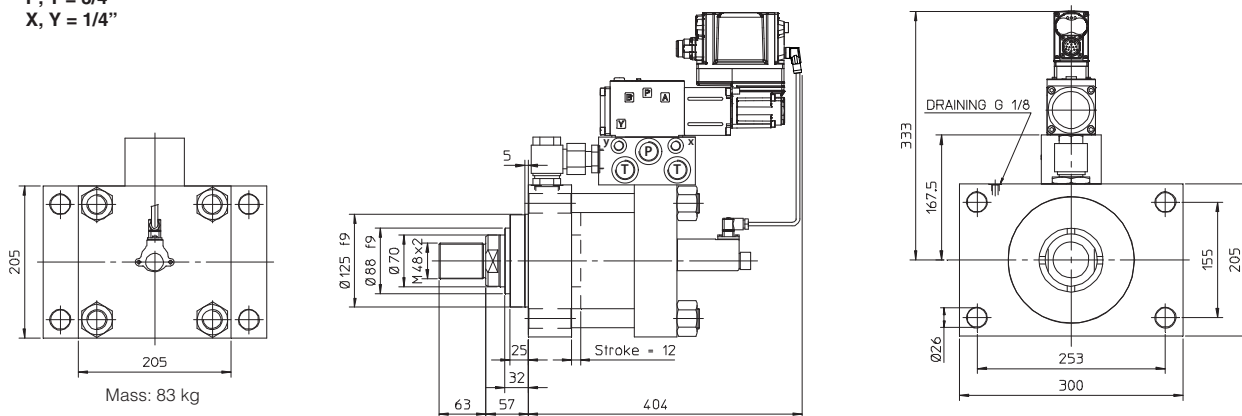

**061810 CKZ-SN-NP-10-200/90\*0012-A/GP**

**P, T = 3/4"**  
**X, Y = 1/4"**

