

Ex-proof proportional directional valves high performance

direct, with LVDT transducer and positive spool overlap - **ATEX, IECEx, EAC, PESO** or **cULus**

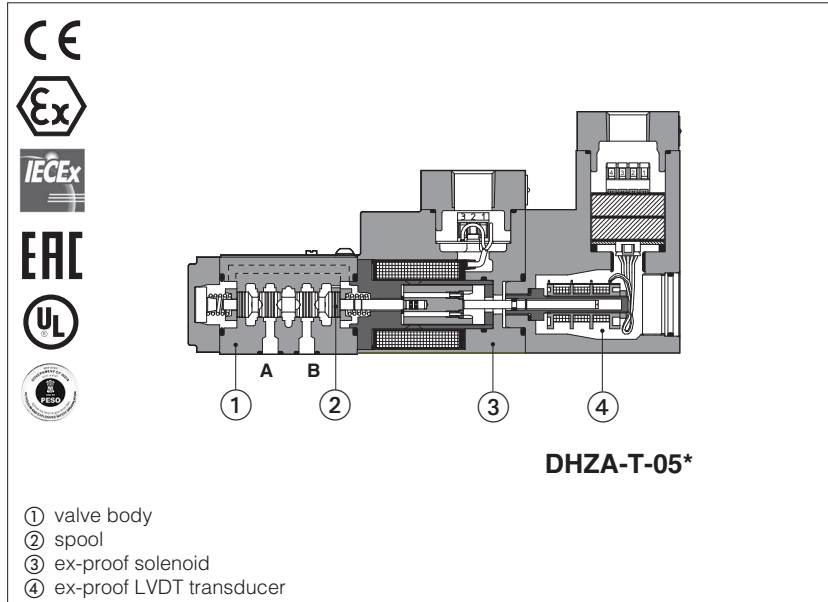

DHZA-T, DKZA-T

Ex-proof high performance proportional valves direct, with LVDT position transducer and positive spool overlap, for best dynamics in directional controls and not compensated flow regulations.

They are equipped with ex-proof proportional solenoids and LVDT transducer certified for safe operations in hazardous environments with potentially explosive atmosphere.

Certifications:

- Multicertification **ATEX, IECEx, EAC** and **PESO** for gas group **II 2G** and dust category **II 2D**
- Multicertification **ATEX** and **IECEx** for gas group **I M2** (mining)
- **cULus** North American certification for gas group **C&D**

The flameproof enclosure of solenoid and transducer, prevents the propagation of accidental internal sparks or fire to the external environment.

The solenoids are also designed to limit the surface temperature within the classified limits.

DHZA:	DKZA:
Size: 06 - ISO 4401	Size: 10 - ISO 4401
Max flow: 60 l/min	Max flow: 150 l/min
Max pressure: 350 bar	Max pressure: 315 bar

1 MODEL CODE

DHZA	/	*	-	T	-	0	-	71	-	L	/	5	/	M	/	*	/	*	/	*
<p>Ex-proof proportional directional valves, direct</p> <p>DHZA = size 06 DKZA = size 10</p> <p>Certification type: Multicertification ATEX, IECEx, EAC, PESO: - = omit for Group II 2G / 2D (1) M = Group I (mining)</p> <p>North American Certification: UL = cULus</p> <p>T = with LVDT transducer</p> <p>Valve size ISO 4401: 0 = 06 1 = 10</p>																				
																		<p>Seals material, see section 6 :</p> <p>- = NBR PE = FKM BT = HNBR (2)</p>		
																		<p>Voltage code: - = standard coil for 24 Vdc Atos drivers 24 = optional coil for 24 Vdc low current drivers</p>		
																		<p>Options (3): B = solenoid and position transducer at side of port A C = position transducer with current feedback 4÷20 mA Y = external drain</p>		

Configuration: Standard Option /B

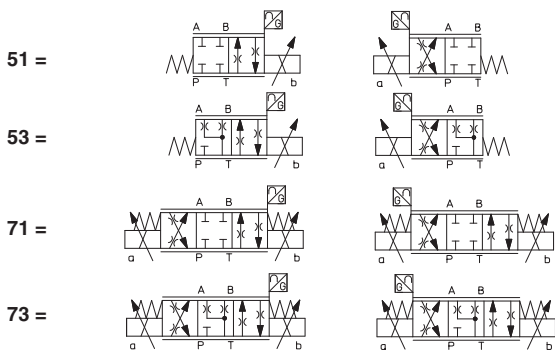

Solenoid and transducer threaded connection

for cable gland fitting:

GK = GK-1/2" - not for **cULus (4)**

M = M20x1,5 - not for **cULus**

NPT = 1/2" NPT

Spool size: 14 (L) 1 (L) 2 (S) 3 (L,S,D) 5 (L,S,D)

DHZA = 1 4,5 8 18 28

DKZA = - - - 45 75

Nominal flow (l/min) at Δp 10 bar P-T

Spool type, regulating characteristics:

L = linear

S = progressive

D = differential-progressive



P-A = Q, B-T = Q/2
P-B = Q/2, A-T = Q

(1) The valves with Multicertification for Group II are also certified for Indian market according to **PESO** (Petroleum and Explosives Safety Organization). The PESO certificate can be downloaded from www.atos.com

(2) Not for multicertification **M** group I (mining) **(3)** Possible combined options: /BC, /BY, /CY, /BCY **(4)** Approved only for the Italian market

⚠ The pressure at T port makes difficult the manual override operation that can be possible only if its value is lower than 50 bar

2 ELECTRONIC DRIVERS

Electronic drivers are factory set with max current limitation for ex-proof valves.

Please include in the driver order also the complete code of the connected ex-proof proportional valve.

Drivers model	E-BM-TEB-* /A	E-BM-TES-* /A
Type	digital	digital
Format	DIN-rail panel	
Data sheet	GS230	GS240

3 GENERAL CHARACTERISTICS

Assembly position	Any position
Subplate surface finishing to ISO 4401	Acceptable roughness index, Ra ≤0,8 recommended Ra 0,4 - flatness ratio 0,01/100
MTTFd valves according to EN ISO 13849	150 years, see technical table P007
Ambient temperature range	Standard = -20°C ÷ +70°C /PE option = -20°C ÷ +70°C /BT option = -40°C ÷ +60°C
Storage temperature range	Standard = -20°C ÷ +80°C /PE option = -20°C ÷ +80°C /BT option = -40°C ÷ +70°C
Surface protection	Zinc coating with black passivation - salt spray test (EN ISO 9227) > 200h
Compliance	Explosion proof protection, see section 7 -Flame proof enclosure "Ex d" -Dust ignition protection by enclosure "Ex t" RoHs Directive 2011/65/EU as last update by 2015/65/EU REACH Regulation (EC) n°1907/2006

4 HYDRAULIC CHARACTERISTICS - based on mineral oil ISO VG 46 at 50 °C

Valve model	DHZA					DKZA		
Pressure limits [bar]	ports P, A, B = 350; T = 210 (250 with external drain /Y) Y = 10					ports P, A, B = 315; T = 210 (250 with external drain /Y) Y = 10		
Configuration	51, 53, 71, 73					51, 53, 71, 73		
Spool type	L14	L1	S2	L3, S3, D3	L5, S5, D5	L3, S3, D3	L5, S5, D5	
Max flow [l/min]								
Δp P-T	Δp = 10 bar	1	4,5	8	18	28	45	75
	Δp = 30 bar	1,7	8	14	30	50	80	130
	max permissible flow	2,6	1	21	40	60	90	150
	Δp max P-T [bar]	70	70	70	50	50	40	40
Leakage [cm³/min]	<30 (at p = 100 bar); <135 (at p = 350 bar)					<80 (at p = 100 bar); <600 (at p = 315 bar)		
Response time (1) [ms]	≤ 20					≤ 25		
Hysteresis [% of max regulation]						≤ 0,2		
Repeatability [% of max regulation]						± 0,1		
Thermal drift	zero point displacement < 1% at ΔT = 40°C							

Note: above performance data refer to valves coupled with Atos electronic drivers, see section 2

(1) 0-100% step signal

5 ELECTRICAL CHARACTERISTICS

Max. power	35W
Insulation class	H (180°) Due to the occurring surface temperatures of the solenoid coils, the European standards ISO 13732-1 and EN982 must be taken into account
Protection degree with relevant cable gland	Multicertification: IP66/67 to DIN EN60529 UL: raintight enclosure, UL approved
Duty factor	Continuous rating (ED=100%)
Voltage code	standard
Coil resistance R at 20°C	3,2 Ω
Max. solenoid current	2,5 A

6 SEALS AND HYDRAULIC FLUID - for other fluids not included in below table, consult Atos Technical Office

Seals, recommended fluid temperature	NBR seals (standard) = -20°C ÷ +60°C, with HFC hydraulic fluids = -20°C ÷ +50°C FKM seals (/PE option) = -20°C ÷ +80°C HNBR seals (/BT option) = -40°C ÷ +60°C, with HFC hydraulic fluids = -40°C ÷ +50°C		
Recommended viscosity	20 ÷ 100 mm²/s - max allowed range 15 ÷ 380 mm²/s		
Max fluid contamination level	normal operation	ISO4406 class 18/16/13 NAS1638 class 7	see also filter section at
	longer life	ISO4406 class 16/14/11 NAS1638 class 5	www.atos.com or KTF catalog
Hydraulic fluid	Suitable seals type	Classification	Ref. Standard
Mineral oils	NBR, FKM, HNBR	HL, HLP, HLPD, HVLP, HVLPD	DIN 51524
Flame resistant without water	FKM	HFDU, HFDR	ISO 12922
Flame resistant with water (1)	NBR, HNBR	HFC	

⚠ The ignition temperature of the hydraulic fluid must be 50°C higher than the max solenoid surface temperature

(1) Performance limitations in case of flame resistant fluids with water:

- max operating pressure = 210 bar
- max fluid temperature = 50°C

7 CERTIFICATION DATA

Valve type	DHZA DKZA		DHZA/M DKZA/M	DHZA/UL DKZA/UL	
Certifications	Multicertification Group II ATEX IECEX EAC PESO		Multicertification Group I ATEX IECEX	North American cULus	
Solenoid certified code	OZA-T		OZAM-T	OZA-T/EC	
Type examination certificate (1)	ATEX: CESI 02 ATEX 014 IECEX: IECEX CES 10.0010x EAC: TC RU C-IT. 08.B.01784 PESO: P338131		ATEX: CESI 03 ATEX 057x IECEX: IECEX CES 12.0007x	20170324 - E366100	
Method of protection	<ul style="list-style-type: none"> • ATEX, EAC Ex II 2G Ex d IIC T6/T4/T3 Gb Ex II 2D Ex tb IIIC T85°C/T200°C Db • IECEX Ex d IIC T6/T4/T3 Gb Ex tb IIIC T85°C/T200°C Db • PESO Ex II 2G Ex d IIC T6/T4 Gb 		<ul style="list-style-type: none"> • ATEX Ex I M2 Ex db I Mb • IECEX Ex db I Mb 	<ul style="list-style-type: none"> • UL 1203 Class I, Div.I, Groups C & D Class I, Zone I, Groups IIA & IIB 	
Temperature class	T4	T3	-	T4	T3
Surface temperature	≤ 135 °C	≤ 200 °C	≤ 150 °C	≤ 135 °C	≤ 200 °C
Ambient temperature (2)	-40 ÷ +40 °C	-40 ÷ +70 °C	-20 ÷ +60 °C	-40 ÷ +55 °C	-40 ÷ +70 °C
Applicable standards	EN 60079 EN 60079 EN 60079		IEC 60079-0 IEC 60079-1 IEC 60079-31	UL 1203 and UL429, CSA 22.2 n°30 CSA 22.2 n°139-13	
Cable entrance: threaded connection	GK = GK-1/2" M = M20x1,5 NPT = 1/2" NPT		1/2" NPT		

(1) The type examiner certificates can be downloaded from www.atos.com

(2) The solenoids **Group II** and **cULus** are certified for minimum ambient temperature -40°C

In case the complete valve must withstand with minimum ambient temperature of -40°C, select **/BT** in the model code

WARNING: service work performed on the valve by the end users or not qualified personnel invalidates the certification

8 EX PROOF SOLENOIDS WIRING

Multicertification	cULus certification
<p>n°8 M4x20 locking torque 4Nm</p>	<p>n°8 M4x20 locking torque 4Nm</p>
<p>① solenoid cover with threaded connection for cable gland fitting ② transducer cover with threaded connection for cable gland fitting ③ solenoid terminal board for cables wiring ④ transducer terminal board for cables wiring ⑤ screw terminal for additional equipotential grounding</p> <p>Solenoid wiring</p> <p>1 = Coil PCB 3 poles terminal board 2 = GND suitable for wires cross sections 3 = Coil up to 2,5 mm² (max AWG14)</p> <p>Position transducer wiring</p> <p>1 = Output signal PCB 4 poles terminal board 2 = Supply -15 V suitable for wires cross sections 3 = Supply +15 V up to 2,5 mm² (max AWG14) 4 = GND</p>	<p>① solenoid cover with threaded connection for cable gland fitting ② transducer cover with threaded connection for cable gland fitting ③ solenoid terminal board for cables wiring ④ transducer terminal board for cables wiring</p> <p>Solenoid wiring ⚠ Pay attention to respect the polarity</p> <p>1 = Coil + PCB 3 poles terminal board suggested cable section up to 1,5 mm² 2 = GND (max AWG16), see section 9 note 1 3 = Coil -</p> <p>alternative GND screw terminal connected to solenoid housing</p> <p>Position transducer wiring</p> <p>1 = Output signal PCB 4 poles terminal board suggested cable section up to 1,5 mm² 2 = Supply -15 V (max AWG16), see section 9 note 1 3 = Supply +15 V 4 = GND</p>

9 CABLE SPECIFICATION AND TEMPERATURE - Power supply and grounding cables have to comply with following characteristics:

Multicertification Group I and Group II

Power supply: section of coil connection wires = 2,5 mm²

Grounding: section of internal ground wire = 2,5 mm²
section of external ground wire = 4 mm²

cULus certification:

- Suitable for use in Class I Division 1, Gas Groups C
- Armored Marine Shipboard Cable which meets UL 1309
- Tinned Stranded Copper Conductors
- Bronze braided armor
- Overall impervious sheath over the armor

Any Listed (UBVZ/UBVZ7) Marine Shipboard Cable rated 300 V min, 15A min. 3C 2,5 mm² (14 AWG) having a suitable service temperature range of at least -25°C to +110°C ("BT" Models require a temperature range from -40°C to +110°C)

Note 1: For Class I wiring the 3C 1,5 mm² AWG 16 cable size is admitted only if a fuse lower than 10 A is connected to the load side of the solenoid wiring.

9.1 Cable temperature

The cable must be suitable for the working temperature as specified in the "safety instructions" delivered with the first supply of the products.

Multicertification

Max ambient temperature [°C]	Temperature class		Max surface temperature [°C]		Min. cable temperature [°C]	
	Goup I	Goup II	Goup I	Goup II	Goup I	Goup II
40 °C	-	T4	150 °C	135 °C	-	90 °C
60 °C	-	-	150 °C	-	110 °C	-
70 °C	N.A.	T3	N.A.	200 °C	N.A.	120 °C

cULus certification

Max ambient temperature [°C]	Temperature class	Max surface temperature [°C]	Min. cable temperature
55 °C	T4	135 °C	100 °C
70 °C	T3	200 °C	100 °C

10 CABLE GLANDS - only **Multicertification**

Cable glands with threaded connections GK-1/2", 1/2"NPT or M20x1,5 for standard or armoured cables have to be ordered separately, see tech. table **KX800**

Note: a Loctite sealant type 545, should be used on the cable gland entry threads

11 OPTIONS

B = Solenoid and position transducer at side of port A of the main stage. For hydraulic configuration vs reference signal, see section **12**

C = Position trasducer with current feedback 4±20 mA, suggested in case of long distance between the electric driver and the proportional valve

Y = External drain, to be selected if the pressure at T port is higher than the max allowed limits

11.1 Possible combined options: /BC, /BY, /CY, /BCY

12 DIAGRAMS - based on mineral oil ISO VG 46 at 50 °C

Regulation diagrams of valves with configurations 51, 53, 71, 73 (positive spool overlap) - values measure at Δp 30 bar P-T

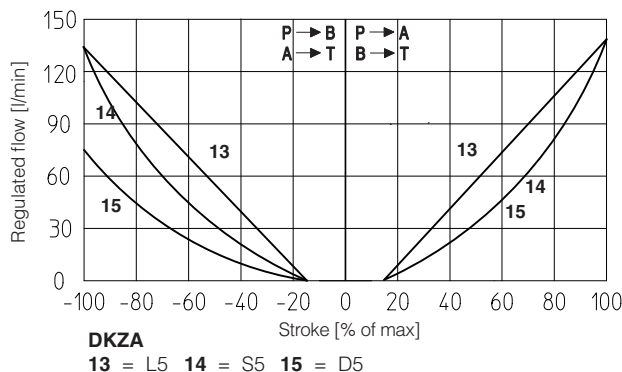
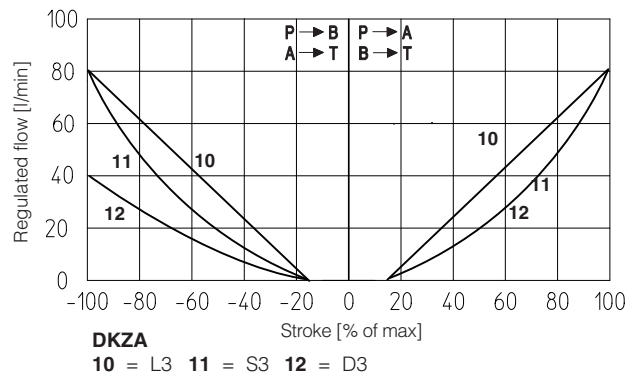
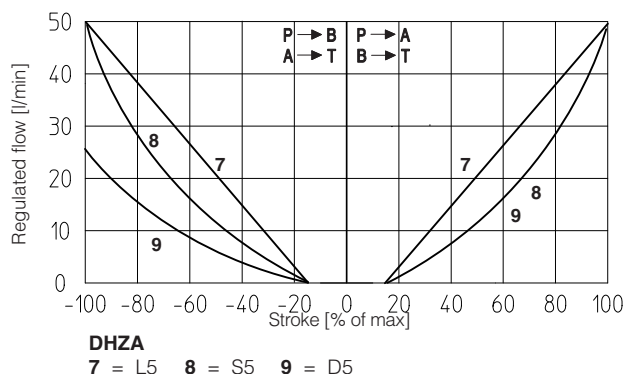
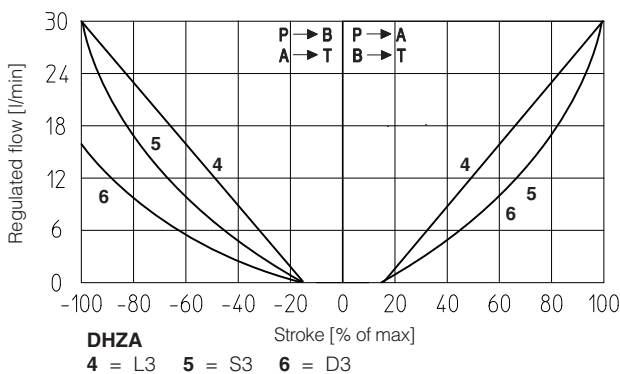
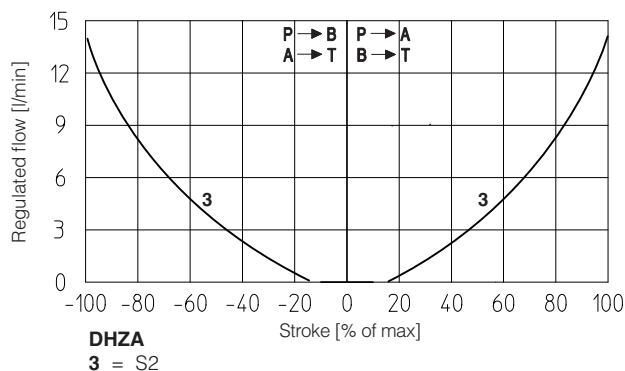
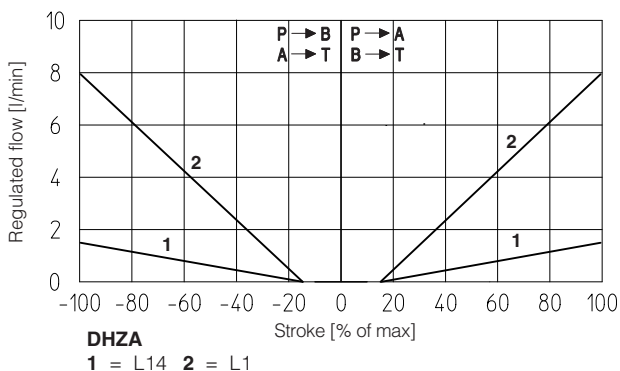

13 FASTENING BOLTS AND SEALS

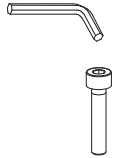
	<p>DHZA</p> <p>Fastening bolts: 4 socket head screws M5x50 class 12.9 Tightening torque = 8 Nm</p>	<p>DKZA</p> <p>Fastening bolts: 4 socket head screws M6x40 class 12.9 Tightening torque = 15 Nm</p>
	<p>Seals: 4 OR 108; Diameter of ports P, A, B, T: \varnothing 7,5 mm (max) 1 OR 2025 Diameter of port Y: \varnothing = 3,2 mm (only for /Y option)</p>	<p>Seals: 5 OR 2050; Diameter of ports P, A, B, T: \varnothing 11,5 mm (max) 1 OR 108 Diameter of port Y: \varnothing = 5 mm (only for /Y option)</p>

14 INSTALLATION DIMENSIONS FOR DHZA [mm]

ISO 4401: 2005 (see table P005)
 Mounting surface: 4401-03-02-0-05
 (for /Y surface: 4401-03-03-0-05 without port X)

Mass [kg]	
DHZA-T-05	4,0
DHZA-T-07	5,1

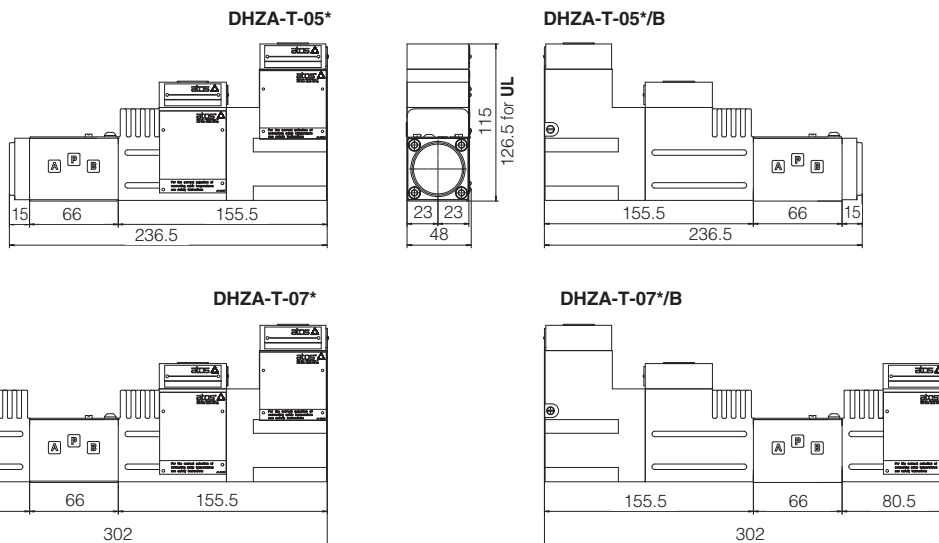

15 INSTALLATION DIMENSIONS FOR DKZA [mm]

ISO 4401: 2005 (see table P005)
 Mounting surface: 4401-05-04-0-05
 (for /Y surface: 4401-03-03-0-05 without port X)

Mass [kg]	
DKZA-T-15	6,2
DKZA-T-17	7,8

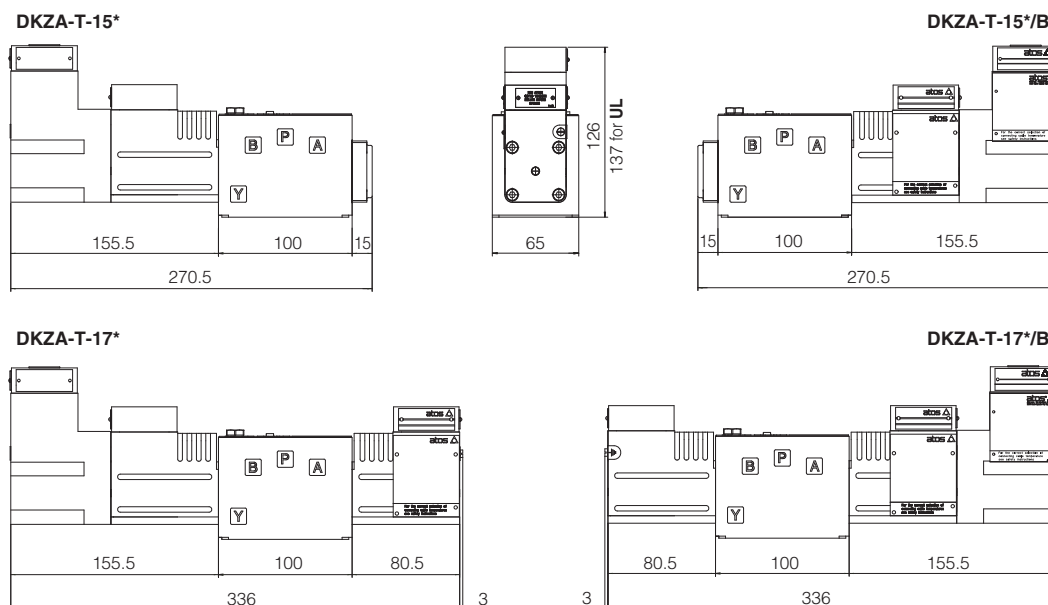

16 RELATED DOCUMENTATION

- X010 Basics for electrohydraulics in hazardous environments
- X020 Summary of Atos ex-proof components certified to ATEX, IECEX, EAC, PESO
- X030 Summary of Atos ex-proof components certified to cULus
- FX900 Operating and maintenance information for ex-proof proportional valves
- KX800 Cable glands for ex-proof valves
- P005 Mounting surfaces for electrohydraulic valves