

DL3B

8 WATT SOLENOID OPERATED DIRECTIONAL CONTROL VALVE SERIES 10

SUBPLATE MOUNTING ISO 4401-03

p max **280** bar
Q max **60** l/min

MOUNTING SURFACE

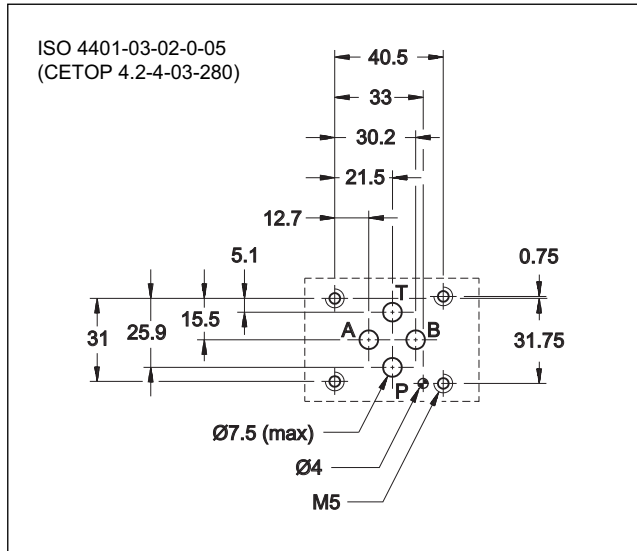

PERFORMANCES

(with mineral oil of viscosity of 36 cSt at 50°C)

Maximum operating pressure: - ports P - A - B - port T	bar	280 210
Maximum flow rate	l/min	50
Pressure drop $\Delta p-Q$	see paragraph 4	
Operating limits	see paragraph 5	
Electrical features	see paragraph 7	
Ambient temperature range	°C	-20 / +50
Fluid temperature range	°C	-20 / +80
Fluid viscosity range	cSt	10 ÷ 400
Fluid contamination degree	according to ISO 4406:1999 class 20/18/15	
Recommended viscosity	cSt	25
Mass: single solenoid valve double solenoid valve	kg	1,5 2

OPERATING PRINCIPLE

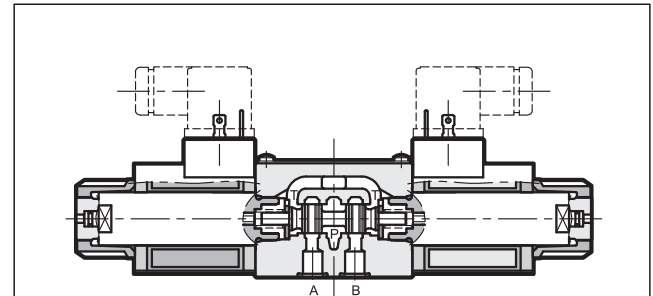

- 8 watt direct acting, subplate mounting directional control valve, with mounting surface according to ISO 4401-03 standards.
- Compact design with reduced solenoid dimensions, suitable for mini-power packs and mobile and agricultural applications.
- The valve body is made with high strength iron castings provided with wide internal passages in order to minimize the flow pressure drop. Wet armature solenoids with interchangeable coils are used (for further information on solenoids see par. 7).

- The valve is supplied with 4 way designs and with several interchangeable spools with different porting arrangements.
- It is available also with zinc-nickel surface treatment, that ensures a salt spray resistance up to 240 hours.
- The valve is available with DC current solenoids with 24 V power supply.

1 - IDENTIFICATION CODE

	D	L	3	B	-	/	10	-	DL24	K1	
--	----------	----------	----------	----------	---	---	-----------	---	-------------	-----------	--

Solenoid operated directional control valve

Compact version

ISO 4401-03 size

Spool type (see paragraph 3):

S*	TA
SA*	TB
SB*	RK

Series N.

(the overall and mounting dimensions remain unchanged from 10 to 19)

Seals:

N = NBR seals for mineral oil (**standard**)

V = FPM seals for special fluids

Option:
Surface treatment not standard.
Omit if not required (see **NOTE**)

Coil electrical connection:
plug for connector type EN 175301-803 (ex DIN 43650) (**standard**)

DC power supply 24 V

NOTE: Standard surface treatment is phosphating black.
On request we can supply these valves with zinc-nickel finishing, suitable to ensure a salt spray resistance up to 240 h (test operated according to UNI EN ISO 9227 standard and test evaluation operated according to UNI EN ISO 10289 standard)
Add **/W7** at the end of the code.

2 - HYDRAULIC FLUIDS

Use mineral oil-based hydraulic fluids HL or HM type, according to ISO 6743-4. For these fluids, use NBR seals (code N). For fluids HFDR type (phosphate esters) use FPM seals (code V). For the use of other fluid types such as HFA, HFB, HFC, please consult our technical department. Using fluids at temperatures higher than 80 °C causes a faster degradation of the fluid and of the seals characteristics. The fluid must be preserved in its physical and chemical characteristics.

3 - SPOOL TYPE

<p>Type S*: 2 solenoids - 3 positions with spring centering</p> <p>S1</p> <p>S2</p> <p>S3</p> <p>S4</p>	<p>Type SA*: 1 solenoid side A 2 positions (central + external) with spring centering</p> <p>SA1</p> <p>SA2</p> <p>SA3</p> <p>SA4</p>	<p>Type SB*: 1 solenoid side B 2 positions (central + external) with spring centering</p> <p>SB1</p> <p>SB2</p> <p>SB3</p> <p>SB4</p>
<p>Type RK: 2 solenoids - 2 positions with mechanical retention</p> <p>RK</p>	<p>Type TA: 1 solenoid side A 2 external positions with return spring</p> <p>TA</p> <p>TA02</p>	<p>Type TB: 1 solenoid side B 2 external positions with return spring</p> <p>TB</p> <p>TB02</p>

NOTE: Others spools available on request only.

4 - PRESSURE DROPS $\Delta P-Q$

(obtained with viscosity of 36 cSt at 50 °C)

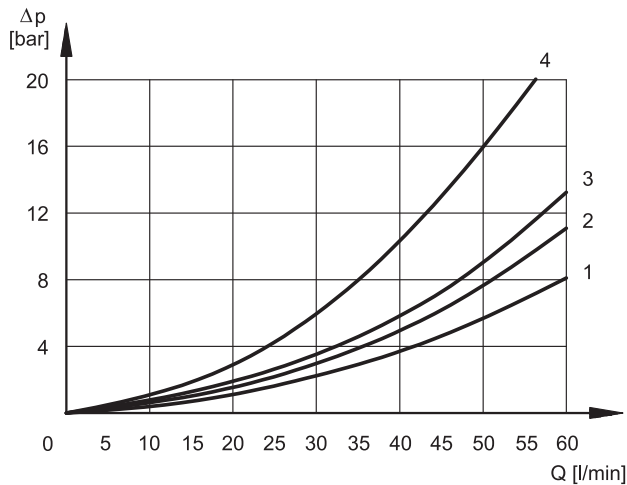

ENERGIZED VALVE

SPOOL	FLOW DIRECTIONS			
	P→A	P→B	A→T	B→T
	CURVES ON GRAPH			
S1	2	3	3	2
S2	1	1	1	1
S3	3	3	1	1
S4	4	4	4	4
RK	3	3	3	3
TA, TB	3	3	3	3
TA02, TB02	1	1	1	1

For the pressure drop with a de-energized valve P→T of the spools S2 and S4 refer to the curve 3; for the spool S4 refer to the curve 4.

5 - OPERATING LIMITS

The curves define the flow rate operating fields according to the valve pressure of the different versions.

The values have been obtained according to ISO 6403 norm with solenoids at rated temperature and supplied with voltage equal to 90% of the nominal voltage. The value have been obtained with mineral oil, viscosity 36 cSt, temperature 50 °C and filtration according to ISO 4406:1999 class 18/16/13.

The limits for TA02 and TA spools refer to the 4-way operation. The operating limits of a 4-way valve in 3-way operation or with port A or B plugged or without flow are shown in the chart on the next page.

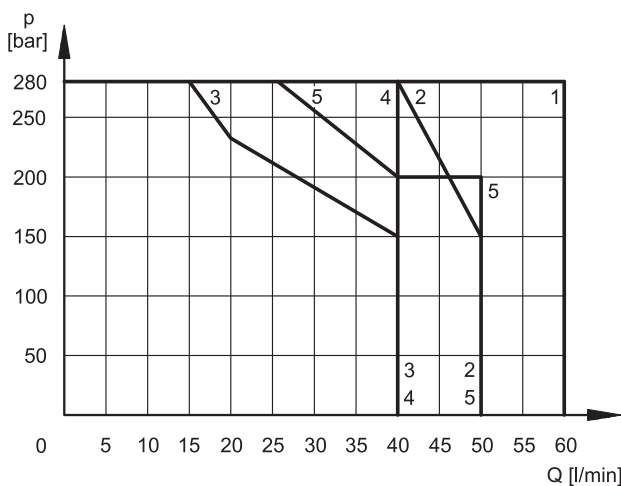

SPOOL	CURVE
S1	1
S2	1
S3	3
S4	4
TA, TB	5
TA02, TB02	2
RK	4

6 - SWITCHING TIMES

The values indicated are obtained with spool S1, according to ISO 6403 standard, with mineral oil viscosity 36 cSt at 50°C.

TIMES (±10%) [ms]	
ENERGIZING	DE-ENERGIZING
25 ÷ 75	15 ÷ 25



7 - ELECTRICAL FEATURES

7.1 - Solenoids

These are essentially made up of two parts: tube and coil. The tube is threaded into the valve body and includes the armature that moves immersed in oil, without wear. The inner part, in contact with the oil in the return line, ensures heat dissipation.

The coil is fastened to the tube by a threaded ring, and can be rotated 360°, to suit the available space.

SUPPLY VOLTAGE FLUCTUATION	± 10% Vnom
MAX SWITCH ON FREQUENCY	7.000 ins/hr
DUTY CYCLE	100%
ELECTROMAGNETIC COMPATIBILITY (EMC)	In compliance with 2014/30/EU
LOW VOLTAGE	In compliance with 2014/35/EU
CLASS OF PROTECTION : Atmospheric agents IEC 60529 Coil insulation (VDE 0580) Impregnation	IP 65 (NOTE) class H class F

NOTE: The IP65 protection degree is guaranteed only with the connector correctly connected and installed.

7.2 - Current and absorbed power for solenoid valve

The table shows current and power consumption values relevant to the 24 VDC coil.

Coil for direct current (values ± 10%)

	Nominal voltage [V]	Resistance at 20°C [Ω]	Current consumpt. [A]	Power consumpt [W]	Coil code
DL24	24	64.6	0.37	8.92	1903291

8 - ELECTRIC CONNECTORS

Solenoid operated are delivered without connectors. Connectors must be ordered separately. See catalogue 49 000.

9 - DL3B OVERALL AND MOUNTING DIMENSIONS

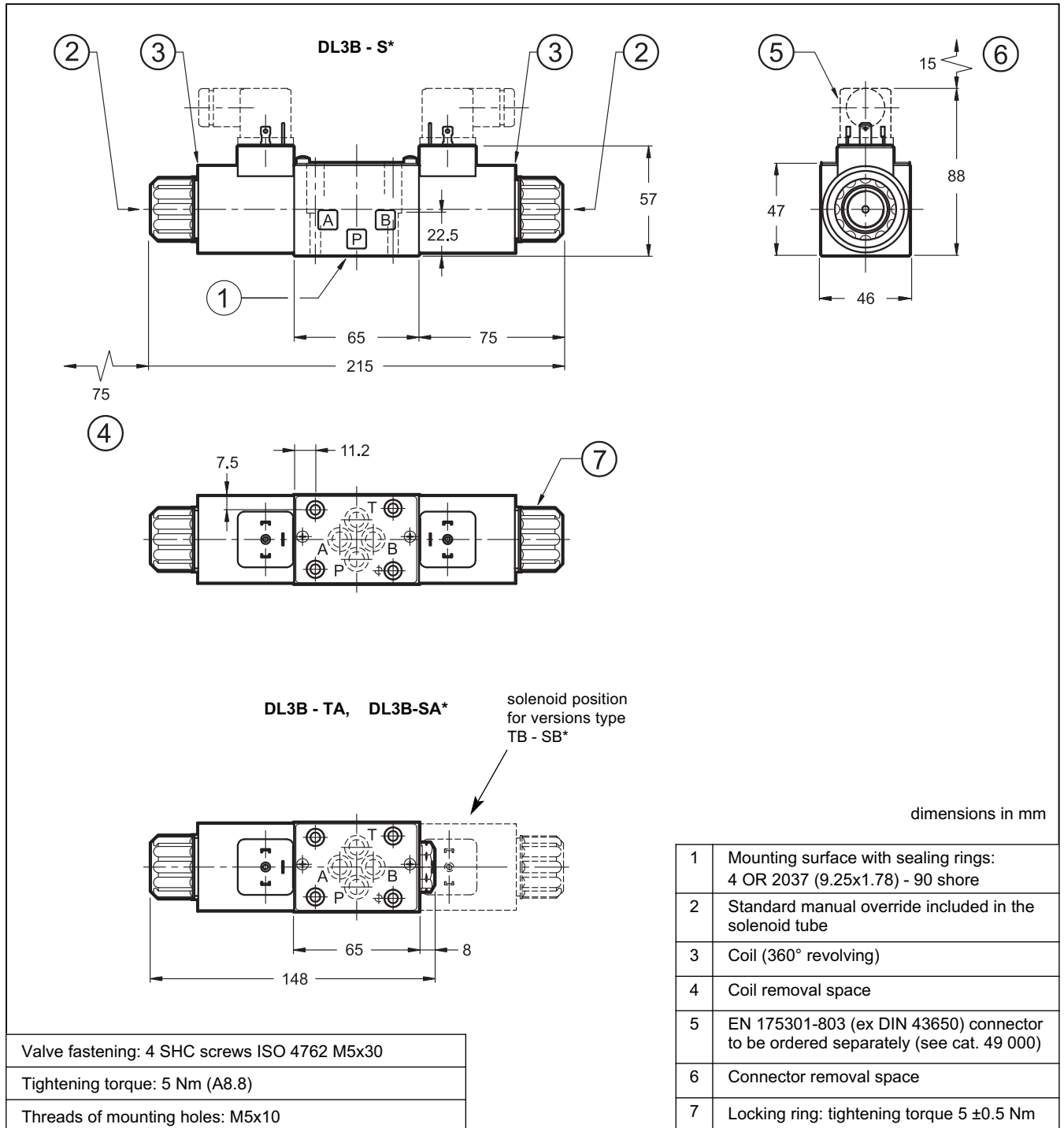

10 - INSTALLATION

Configurations with centering and return springs can be mounted in any position; type RK valves - without springs and with mechanical detent - must be mounted with the longitudinal axis horizontal.

Valve fitting takes place by means of screws or tie rods, fixing the valve on a lapped surface, with values of planarity and smoothness that are equal to or better than those indicated in the drawing.

If the minimum values of planarity or smoothness are not met, fluid leakages between valve and mounting surface can easily occur.

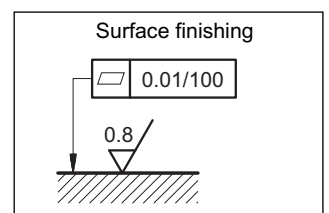

11 - SPARE PARTS FOR SOLENOID VALVE

1	Coil locking ring with seal included cod. 0119412 Tightening torque 5 ±0.5 Nm
2	ORM type 0220-20 (22x2) - 70 Shore
3	Coil C22L3B-DL24K1/11
4	Solenoid tube for standard version: TD22-DL3B/10N (NBR seals) TD22-DL3B/10V (FPM seals) NOTE: OR n°5 included
5	OR type 2062 (15.6x1.78) - 70 Shore
6	N. 4 OR type 2037 (9.25x1.78) - 90 Shore

SEALS KIT

The codes include the O-Ring n° 2, 5 and 6.

Cod. 1985406 NBR seals
Cod. 1985410 FPM (viton) seals

12 - SUBPLATES

(see catalogue 51 000)

Type PMMD-AI3G with rear ports 3/8" BSP
Type PMMD-AL3G with side ports 3/8" BSP