

DS5JB

SOLENOID OPERATED DIRECTIONAL CONTROL VALVE

ALTERNATING CURRENT SERIES 10

NFPA D05 (ISO 4401-05 / CETOP 05)

p max 4600 psi

Q max 32 GPM

MOUNTING INTERFACE

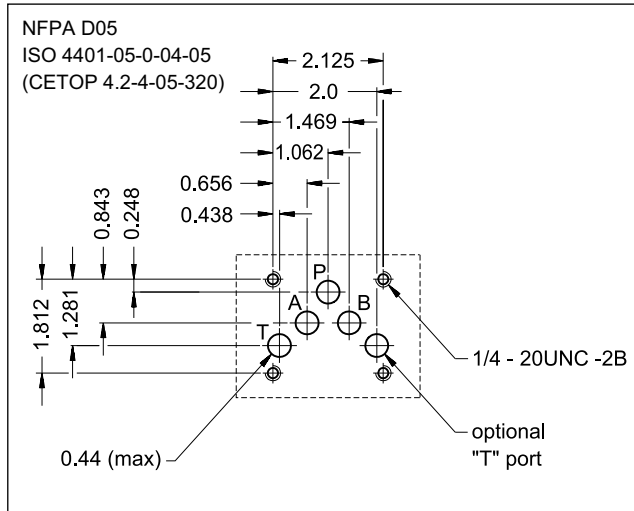

OPERATING PRINCIPLE

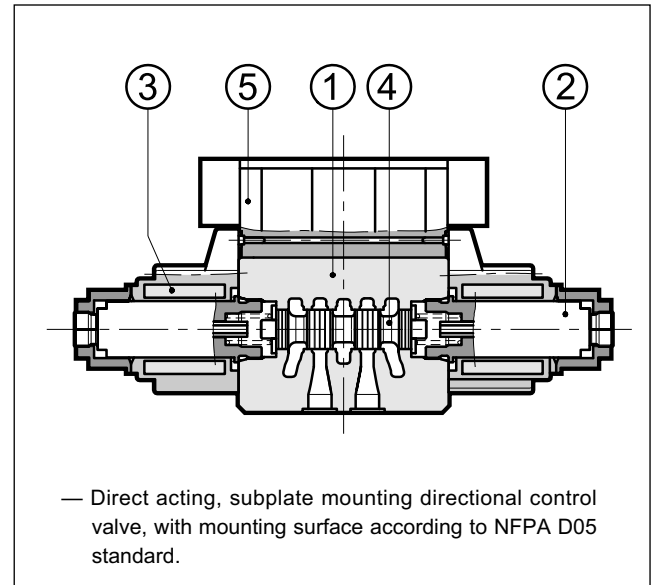

PERFORMANCES (with mineral oil of viscosity of 36 cSt at 50°C)

Maximum operating pressure Ports P - A - B Port T	psi	4600 2000
Maximum flow rate	GPM	32
Pressure drop $\Delta p-Q$	see paragraph 4	
Operating limits	see paragraph 6	
Electrical features	see paragraph 7	
Electrical connections	junction box	
Ambient temperature range	°F	-4 / +125
Fluid temperature range	°F	-4 / +175
Fluid viscosity range	cSt	10 - 400
Fluid contamination degree	according to ISO 4406:1999 class 20/18/15	
Recommended viscosity	cSt	25
Masse: single solenoid valve double solenoid valve	lbs	5.5 7.5

- The valve body (1) is made with high strength iron castings provided with wide internal passages in order to minimize the flow pressure drop. Wet armature solenoids (2) with easily removable interchangeable coils (3) are used (for further information on solenoids see par. 7). It is supplied with junction box (5) for the electrical connection.
- The valve is supplied with 3 or 4 way designs and with several interchangeable spools (4) with different porting arrangements.
- The valve is available with AC solenoids.



1 - IDENTIFICATION CODE

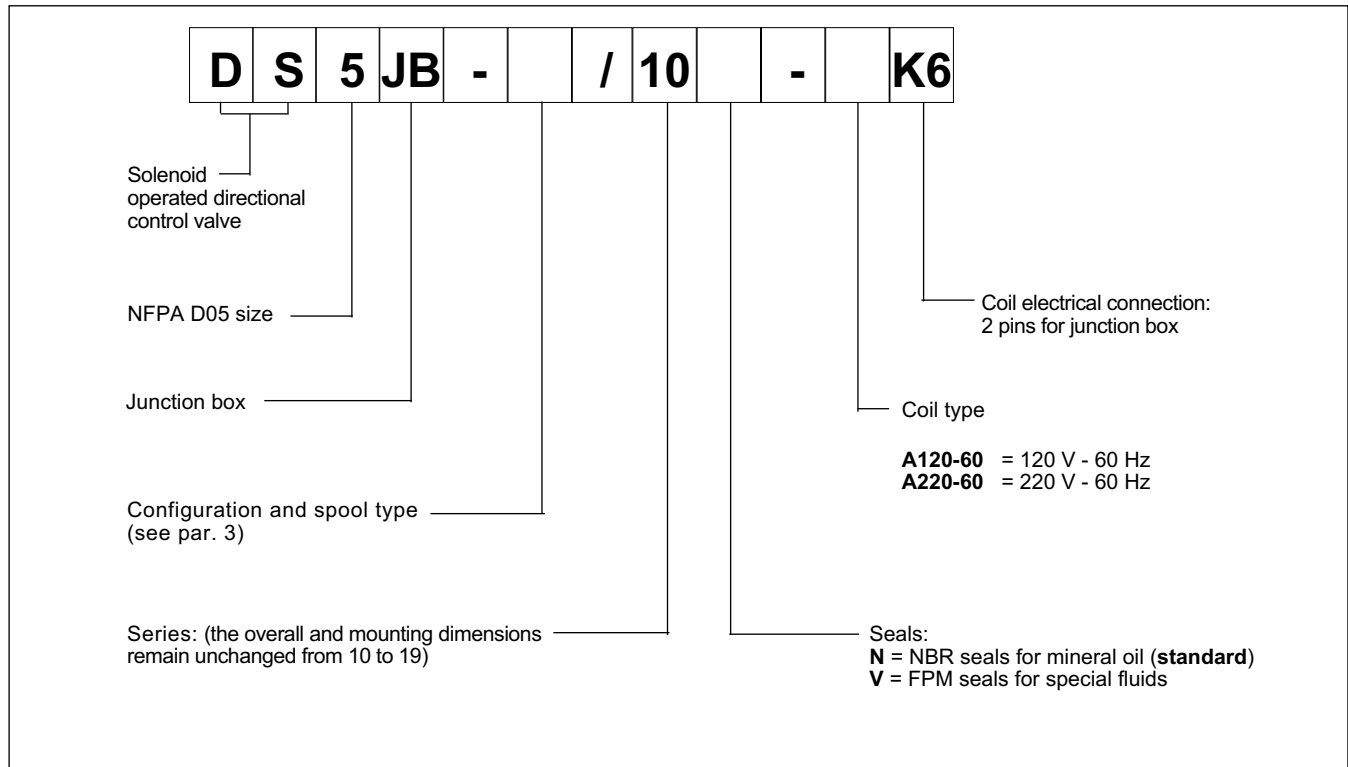

2 - HYDRAULIC FLUIDS

Use mineral oil-based hydraulic fluids HL or HM type, according to ISO 6743-4. For these fluids, use NBR seals (code N). For fluids HFDR type (phosphate esters) use FPM seals (code V). For the use of other fluid types such as HFA, HFB, HFC, please consult our technical department.

Using fluids at temperatures higher than 175 °C causes a faster degradation of the fluid and of the seals characteristics. The fluid must be preserved in its physical and chemical characteristics.

3 - CONFIGURATIONS

Type S*:
2 solenoids - 3 positions
with spring centering

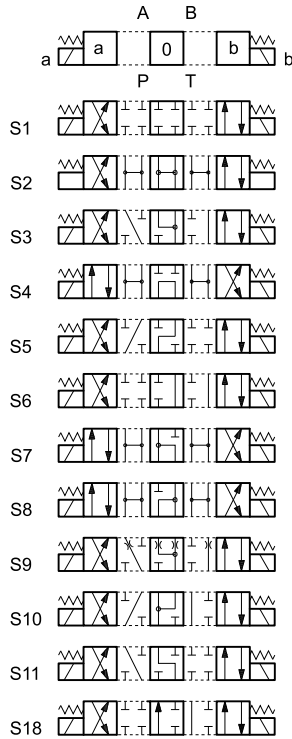

Type SA*:
1 solenoid side A
2 positions (central + external)
with spring centering

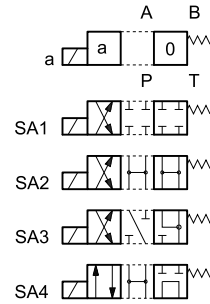

Type SB*:
1 solenoid side B
2 positions (central + external)
with spring centering

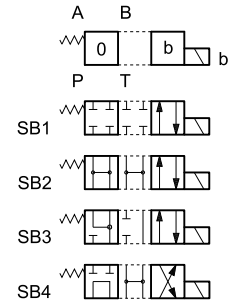

Type TA:
1 solenoid side A
2 external positions
with return spring

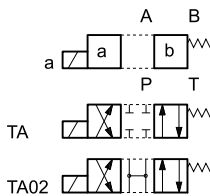

Type TB:
1 solenoid side B
2 external positions
with return spring

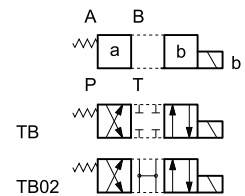

Type RK:
2 solenoids - 2 positions
with mechanical retention

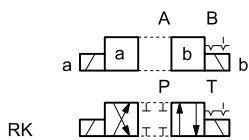

Type TA23 / TB23
three-way valve - 1 solenoid - 2 external positions, return spring

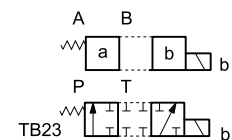
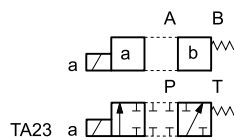

Note: Type TB23 corresponds to type 23TA of the old valve (D4D)

Besides the diagrams shown, which are the most frequently used, other special versions are available: consult our technical department for their identification, feasibility and operating limits.



4 - PRESSURE DROPS Δp -Q (obtained with viscosity 170 SSU at 120 °F)

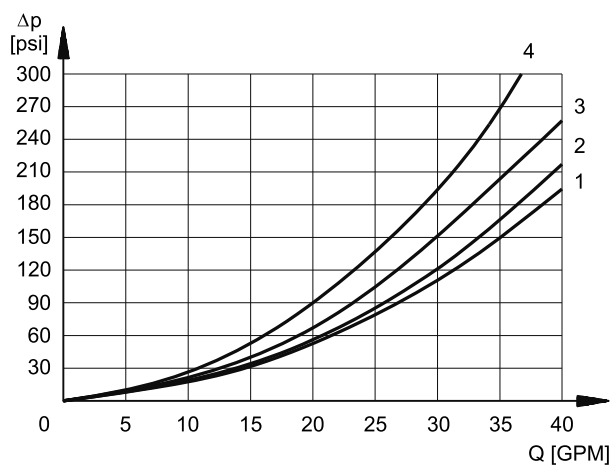

PRESSURE DROPS WITH VALVE ENERGIZED

SPOOL TYPE	FLOW DIRECTION			
	P-A	P-B	A-T	B-T
	CURVES ON GRAPH			
S1, SA1, SB1	2	2	1	1
S2, SA2, SB2	3	3	1	1
S3, SA3, SB3	3	3	2	2
S4, SA4, SB4	1	1	2	2
S5	2	1	1	1
S6	3	3	2	2
S7	1	1	2	2
S8	1	1	2	2
S9	3	3	2	2
S10	1	1	1	1
S11	3	3	2	2
S18	1	2	2	2
TA, TB	3	3	2	2
TA02, TB 02	3	3	2	2
TA23, TB23	4	4		
RK	3	3	2	2

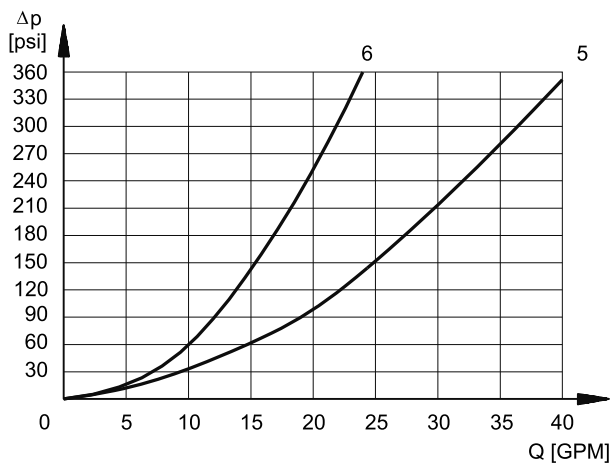

PRESSURE DROPS WITH VALVE IN DE-ENERGIZED POSITION

SPOOL TYPE	FLOW DIRECTION				
	P-A	P-B	A-T	B-T	P-T
	CURVES ON GRAPH				
S2, SA2, SB2					5
S3, SA3, SB3			6	6	
S4, SA4, SB4					5
S5		3			
S6					
S7					
S8					
S9					
S10					
S11					
S18	3				

5 - SWITCHING TIMES

The values indicated are obtained according to ISO 6403 standard, with mineral oil viscosity 170 SSU at 120°F.

SOLENOID TYPE	TIMES	
	ENERGIZING	DE-ENERGIZING
AC	15 ÷ 25 ms	20 ÷ 50 ms



6 - OPERATING LIMITS

The curves define the flow rate operating fields according to the valve pressure with AC solenoids.
The values have been obtained according to ISO 6403, with mineral oil, viscosity 170 SSU, temperature 120 °F.

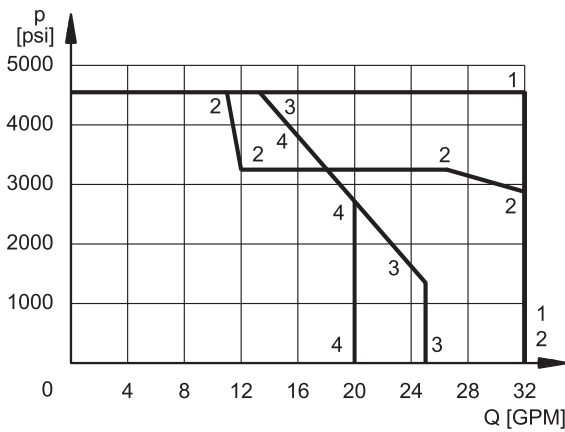

SPOOL TYPE	CURVE	
	P-A	P-B
S1,SA1,SB1	1	1
S2, SA2, SB2	2	2
S3, SA3, SB3	3	3
S4, SA4, SB4	4	4
S5	1	1
S6	2	1
S7	4	4
S8	4	4

SPOOL TYPE	CURVE	
	P-A	P-B
S9	2	2
S10	1	1
S11	1	2
S18	1	1
TA, TB	1	1
TA02, TB02	2	2
TA23, TB23	1	1
RK	1	1

NOTE: The values indicated in the graphs are relevant to the standard solenoid valve. The operating limits can be considerably reduced if a 4-way valve is used as a 3-way valve with port A or B plugged or without flow.

7 - ELECTRICAL FEATURES

7.1 Solenoids

These are essentially made up of two parts: tube and coil. The tube is threaded into the valve body and includes the armature that moves immersed in oil, without wear. The inner part, in contact with the oil in the return line, ensures heat dissipation. The coil is fastened to the tube by a threaded ring.

SUPPLY VOLTAGE FLUNCTUATION	± 10% Vnom
MAX SWITCH ON FREQUENCY	15.000 ins/hr
DUTY CYCLE	100%
Class of protection: Atmospheric agents (CEI EN 60529) Coil insulation (VDE 0580) Impregnation	IP 65 (see note 2) class H class F

Note: The IP65 protection degree is guaranteed only with the connector correctly connected and installed.

7.2 Current and absorbed power

The table shows current and power consumption values at inrush and at holding, relevant to the different coil types for AC current.

Coils (values ± 5%)

Type of coil	Frequency [Hz]	Nominal voltage [V]	Resistance at 20°C [Ohm]	Current consumption at inrush [A]	Current consumption at holding [A]	Power consumption at inrush [VA]	Power consumption at holding [VA]	Code
C26-A120-60K6/10	60	120	9,65	4,5	0,88	540	105,6	1902840
C26-A220-60K6/10		220	29,6	2,5	0,46	550	101,2	1902841

8 - INSTALLATION

Configurations with centering and return springs can be mounted in any position; type RK valves - without springs and with mechanical detent - must be mounted with the longitudinal axis horizontal. Valve fixing is by means of screws or tie rods, with the valve mounted on a lapped surface, with values of planarity and smoothness that are equal to or better than those indicated in the drawing. If the minimum values of planarity and/or smoothness are not met, fluid leakage between valve and mounting surface can easily occur.

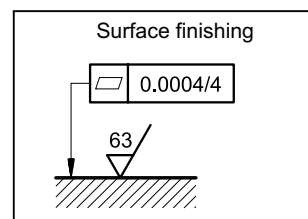

9 - OVERALL AND MOUNTING DIMENSIONS

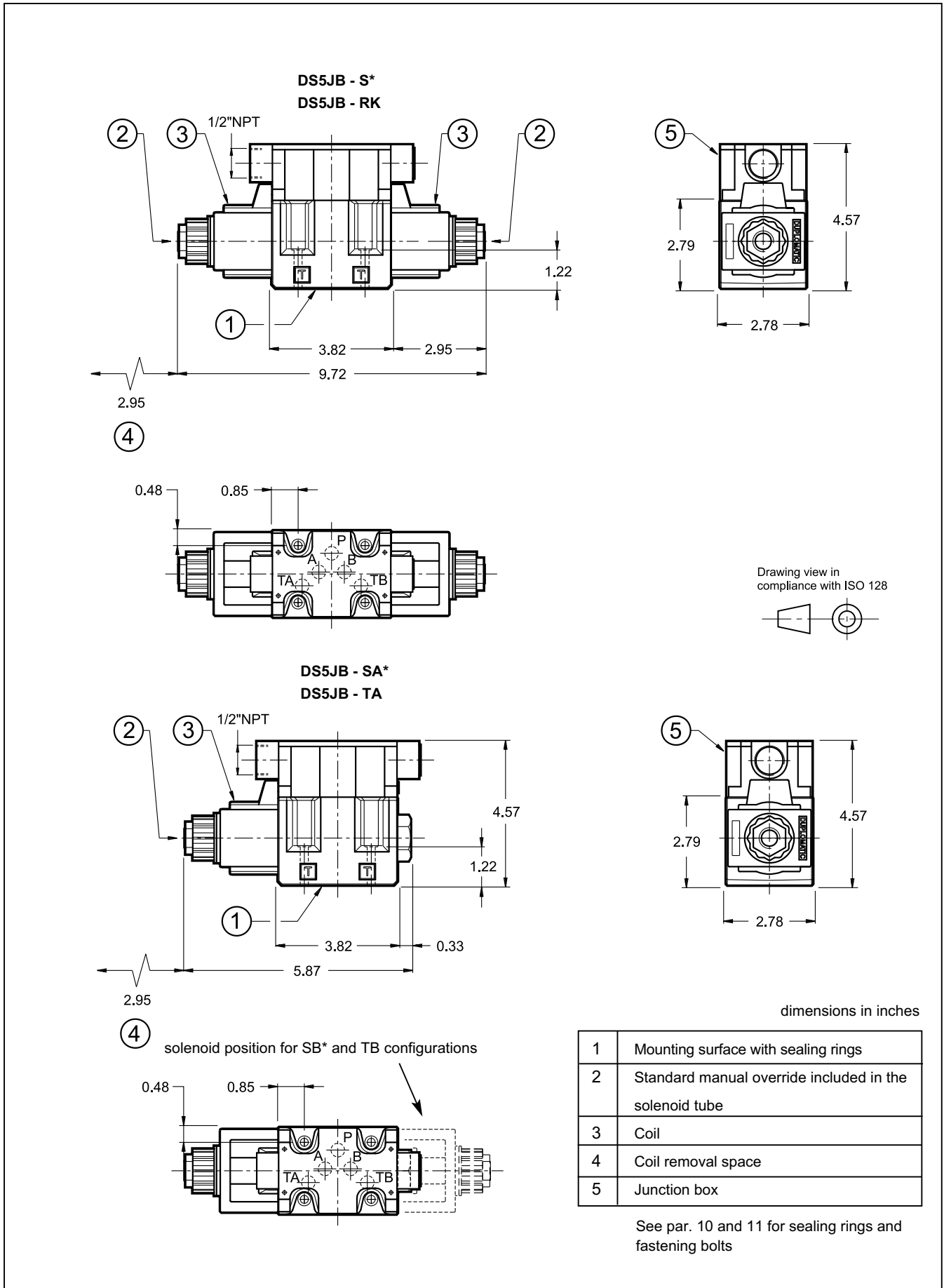

10 - SPARE PARTS FOR AC SOLENOID VALVE

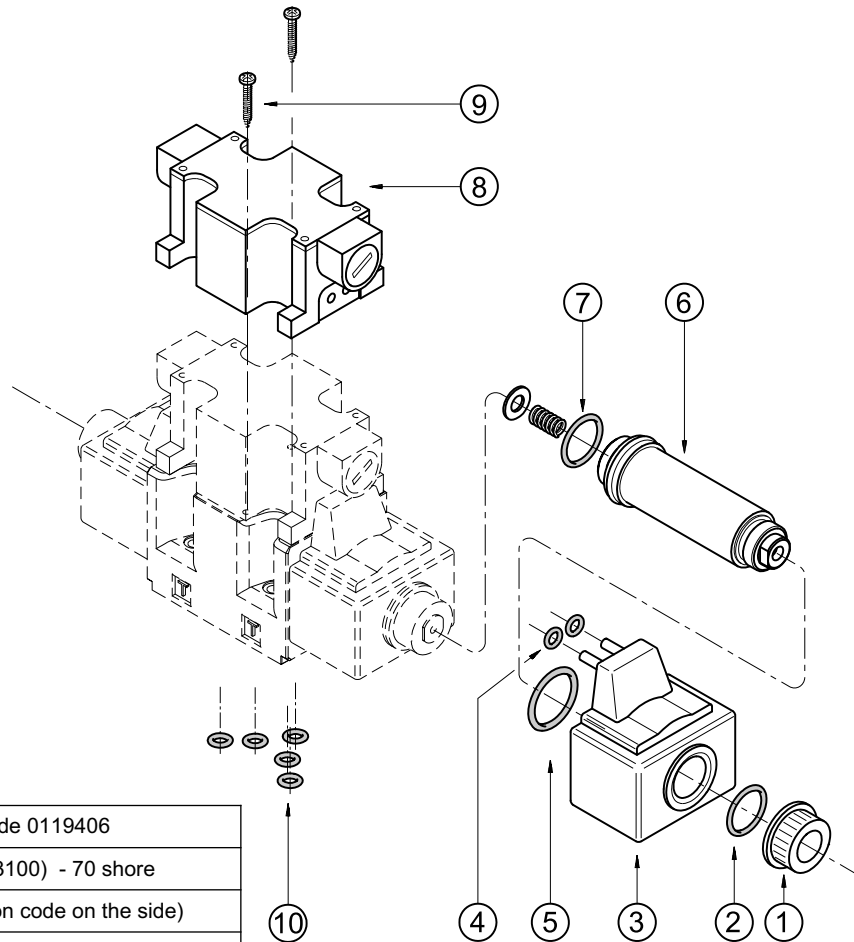

1	Coil locking ring - code 0119406
2	O-Ring type 2-120 (3100) - 70 shore
3	Coil (see identification code on the side)
4	2 O-Ring type 2-007 (2015) - 70 shore
5	O-Ring type 6-454 (ORM-0300-40) 70 shore
6	Solenoid tubes: TA26-M27/10N (NBR seals) TA26-M27/10V (FPM seals) NOTE: the tube is supplied with O-Ring rif. 7
7	2 O-Ring type 3-912 - 70 shore
8	Junction box: EJB5-D/10 (double solenoid valve) EJB5-S/10 (single solenoid valve)
9	2 bolts M3x35 (for single solenoid valve 1 bolt M3x35 + 1 bolt M3x6)
10	5 O-Ring type 2-014 (2050) - 90 shore

COILS IDENTIFICATION CODE

C 26 - K6 / 10

Supply voltage

A120-60 = 120 V - 60 Hz
A220-60 = 220 V - 60 Hz

Series no.: (the overall and mounting dimensions remain unchanged from 10 to 19)

Coil electrical connection:
2 pins for junction box

SEALS KIT

The codes here below include O-Rings ref. 2, 4, 6 and 10

Cod. 1984447 NBR seals

Cod. 1984448 FPM (viton) seals

11 - FASTENING BOLTS

4 bolts type 1/4-20 UNC-2Bx1 3/4 (12.9 class recommended)

Tightening torque 70 lbs·inch