

Pressure transducers type **E-ATR-8**

analog, for open and closed loop systems

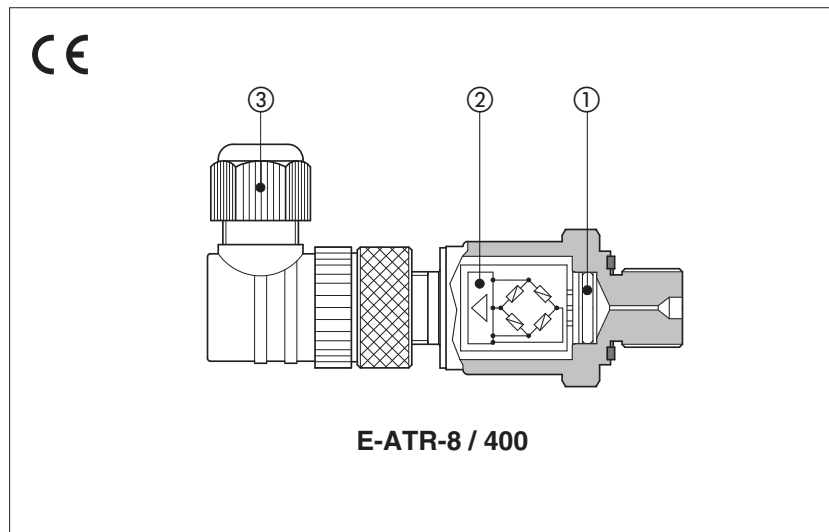

E-ATR-8

This pressure transducers measure the static and dynamic pressure of the hydraulic fluid, supplying a voltage or current output signal.

The sensor is composed by a thin-film circuit ①, with high resistance to overloads and pressure peaks.

The integrated electronic circuit ② supplies an amplified voltage or current output signal, proportional to the hydraulic pressure, with thermal drift compensation.

E-ATR-8 equip pressure control digital proportional valves with integral transducer and electronics, REB/RES execution.

They are also used in association with other Atos digital proportionals to perform closed loop pressure controls:

- variable displacement axial piston pumps, PE(R)S execution (see tech table AS170)
- directional control valves with additional closed loop pressure control, SP and SF options on TES/LES execution (see tech table FS500)

Features:

- Factory preset and calibrated
- Standard 5 pin M12 main connector ③
- IP67 protection degree
- CE mark according to EMC directive

1 MODEL CODE

E-ATR-8	/	400	/	*		*
Pressure transducer						Series number
Pressure measuring range:						
60	= 0 ÷ 60 bar					
100	= 0 ÷ 100 bar					
160	= 0 ÷ 160 bar					
250	= 0 ÷ 250 bar					
400	= 0 ÷ 400 bar					
Options:						
-	= voltage output signal 0 ÷ 10 V					
I	= current output signal 4 ÷ 20 mA					

2 MAIN CHARACTERISTICS

Pressure measuring range	0 ÷ 60/100/160/250/400 bar; other values available on request Note: negative pressure can damage the pressure transducer
Overload pressure	2 x FS without exceeding 600 bar
Burst pressure	5 x FS without exceeding 1700 bar
Response time	≤ 2 ms
Temperature range	Operating -40 ÷ +100 °C; Storage -40 ÷ +100 °C; Fluid: -40 ÷ +100 °C
Thermal drift	@ zero: ≤ ±0,025 % FS/°C max; @ FS: ≤ ±0,025 % FS/°C max
Accuracy	≤ ±1,2 % FS
Non-Linearity	≤ ±0,5 % of FS (BFSL) as per IEC 61298-2
Fluid Compatibility	Hydraulic oil as per DIN51524...535; for water-glycol, phosphate ester and skydrol®, please contact Atos technical department
Power supply	24 Vdc nominal; 14 ÷ 30 Vdc for standard (8 ÷ 30 Vdc for I option); I _{max} 25 mA
Output signal	Standard: voltage output signal 0 ÷ 10 V (3 pins); Min load > maximum output signal / 1 mA I option: current output signal 4 ÷ 20 mA (2 pins); Max load ≤ (power supply - 8 V) / 0,02 mA
Wiring protections	Against reverse polarity on power supply and short-circuit on output signal
Materials	Wetted parts: stainless steel 316L (13-8 PH for sensor); seals: FPM/FKM
Mass	Approx. 57 g
Electromagnetic compatibility (EMC)	According to Directive 2014/30/UE EN 61326 emission (group 1, class B) and immunity (industrial application)
Service life	1x10 ⁶ load cycles
MTTF	> 100 years
Compliance	RoHS Directive 2011/65/EU as last update by 2015/65/EU REACH Regulation (EC) n°1907/2006
Vibration resistance	20 g according to DIN EN 60068-2-6 from 20 to 2000 Hz
Shock resistance	40 g / 6 ms / half-sinusoid, according to DIN EN 60068-2-27
Protection class	IP67 with mating connector
Hydraulic connection	1/4" GAS - DIN 3852 (pressure port orifice Ø 0,6 mm)
Electrical connection	Type: plastic 5 pins M12 at 90° (DIN 43650-C) with cable gland type PG7 for cable max Ø 6 mm Protection: IP67 according to EN 60529; Insulation: according to VDE 0110-C

Notes: FS = Full Scale; BFSL = Best Fit Straight Line

3 INSTALLATION AND COMMISSIONING

3.1 Warning

E-ATR-8 transducers have to be installed as near as possible to the point where the pressure have to be measured, taking care that the oil flow is not turbulent.

3.2 Commissioning

Install the transducer in the hydraulic circuit.

Switch-off the power supply before connecting and disconnecting the transducer connector as shown in scheme 4.

4 ELECTRONIC CONNECTIONS

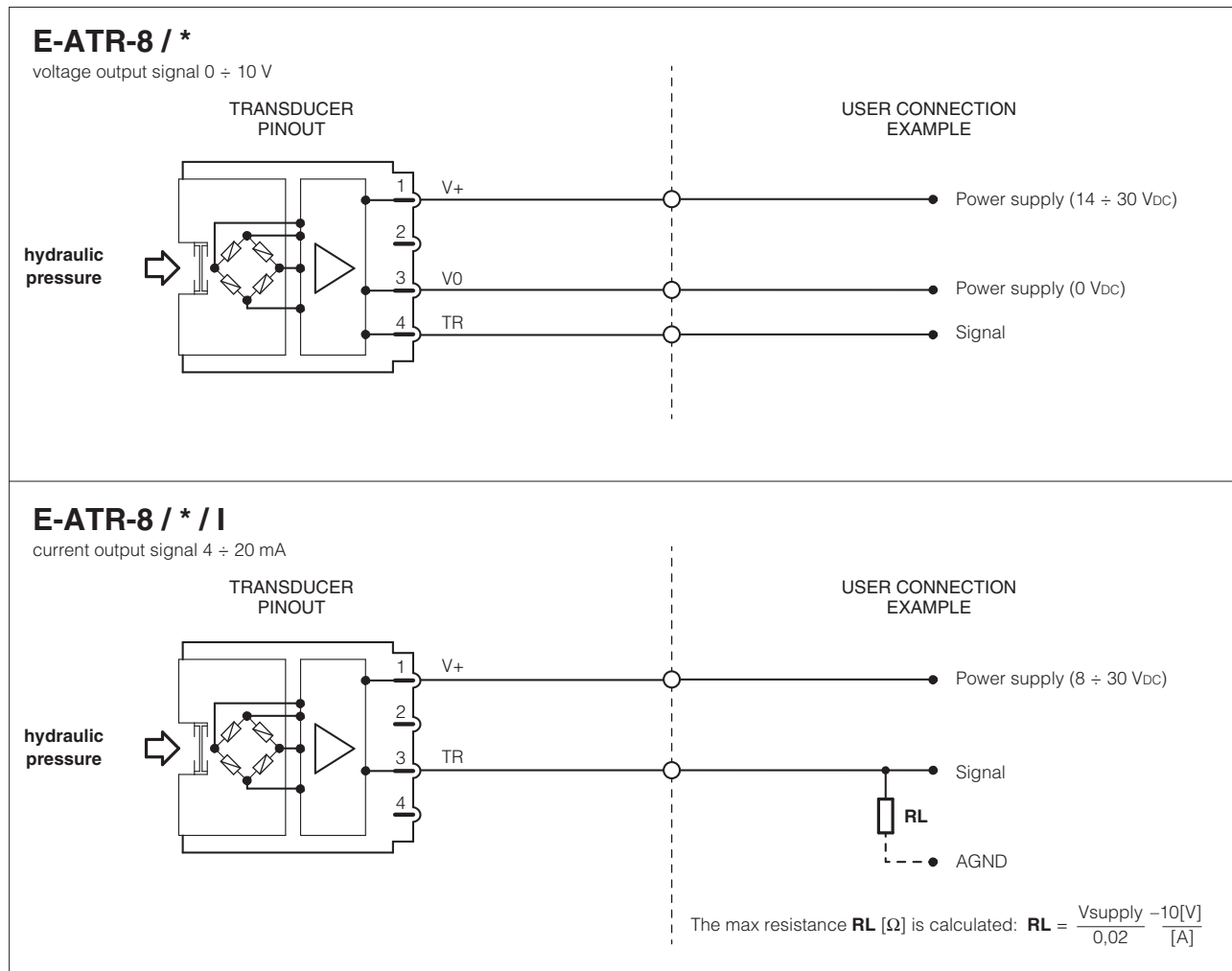

5 OVERALL DIMENSIONS [mm]

