



| | | | | | | |
|------------------|--------------------------------|-------------------------------------|---|--------------------|-------------------|-------------------|
| 60 kN | FORGED STEEL IN MY BODY | DOUBLE ROLLER/TAPPER BEARING | HYDRAULIC INPUTS FROM OPPOSITE SIDES | | | |
| -50 kN | 80 mm | 1/2" BSP | 250 bar | 1/2" BSP | 250 bar | 300 bar |

Rotator's upper mount is applied in FORK form factor of the knuckle joint. Robust and tough built to withstand even overloads. The fork width (between fork ends) is common standard width 80mm and the knuckle pin diameter 35mm.



Hydraulic rotator FHR 6FD2 is ideal for professional use in forestry, agriculture, road and building construction, recycling industry, general cargo and material handling.

| |
|--------------------|
| 30 kN |
| -25 kN |
| 1850 nm |
| 47 kg |
| 25 l/min |



Rotator lower mount is applied in FLANGE form factor to mount direct on grapple / tool surface by fixing with screws

| | | |
|------------------|--------------------|--------------------|
| 173 mm | 1/2" BSP | 1/2" BSP |
|------------------|--------------------|--------------------|

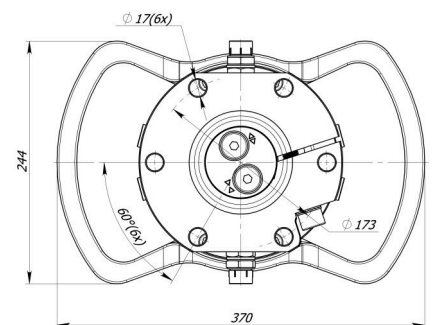
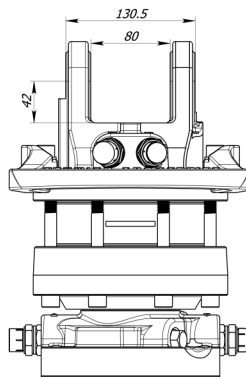
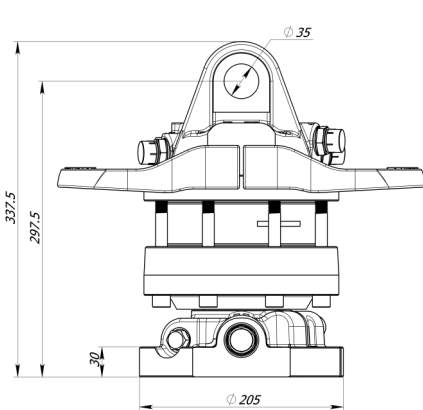

For additional information relating to price levels and technical data, please contact sales@formiko.lv

Formiko Hydraulic s Ltd

Dzirciema Str. 119 k-1,
Rīga LV1055 LATVIA

+371 294 49 552
+371 264 59 383
sales@formiko.lv
www.formiko.lv

On request by special conditions there are metric nipples available for rotator FHR 6FD2



FORESTRY GENERAL CARGO AGRICULTURE CONSTRUCTION RECYCLING





Hydraulic rotator FHR 6FD2 is ideal for professional use in forestry, agriculture, road and building construction, recycling industry, general cargo and material handling.



Rotator's upper mount is applied in FORK form factor of the knuckle joint. Robust and tough built to withstand even overloads. The fork width (between fork ends) is common standard width 80mm and the knuckle pin diameter 35mm.



Rotator lower mount is applied in FLANGE form factor to mount direct on grapple / tool surface by fixing with screws



Rotator FHR 6FD2 based on reliable vane type hydraulic motor which delivers torque up to 1850Nm at 25MPa.



Formiko Hydraulics rotator FHR 6FD2 is equipped with double bearings to withstand both tensional and pushing loads.



FHR 6FD2 is designed with opposite hydraulic channels, to ease the hose replacement in case of rupture.



Some parts in rotator are built from shock resistant and deformation resistant forged steel.



Formiko rotator FHR 6FD2 is compatible with FHL 02 series links.



Rotator for shipping is packed in compact solid cardboard box with dimensions 400x250x250mm.



We providing TWO year warranty for this rotator.

For additional information relating to price levels and technical data, please contact sales@formiko.lv

Formiko Hydraulics Ltd

Dzirciema Str. 119 k-1,
Rīga LV1055 LATVIA

+371 294 49 552
+371 264 59 383
sales@formiko.lv
www.formiko.lv

On request by special conditions there are metric nipples
available for rotator FHR 6FD2

