

In line filters, high pressure type FPH

Threaded or SAE flanged ports - max flow 340 l/min, max pressure 420 bar

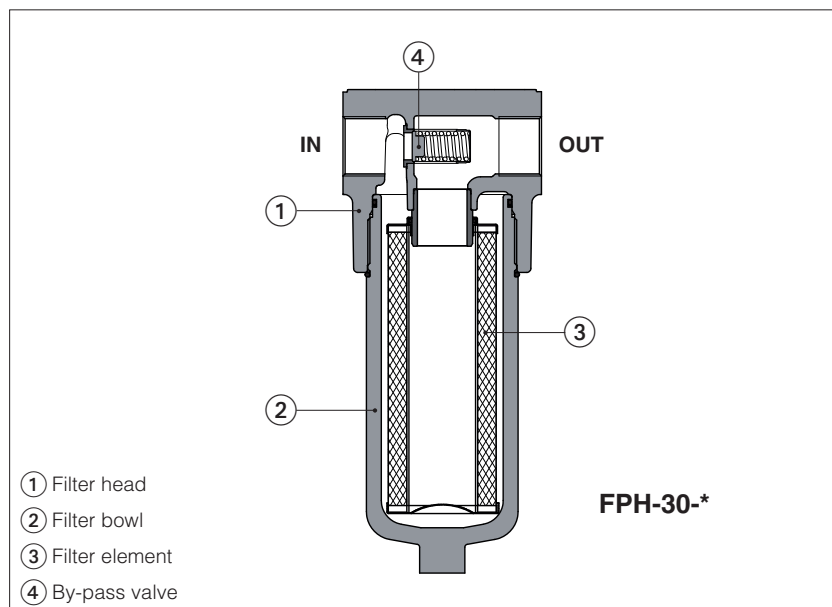

FPH in line filters are designed to protect the whole hydraulic circuit or a single valve from contamination present in the working fluid. They are particularly recommended for circuits with proportional valves.

FPH filters are available with following features:

- two body sizes with BSPP or SAE threaded ports or SAE 6000 flanged ports, from 3/4" to 1 1/2"
- max working pressure up to **420 bar**
- four filter lengths with max flow **340 l/min**
- without or with by-pass valve with cracking pressure 6 bar
- microfibre filter element with filtration rating 4,5 - 7 - 12 µm(c) (βx(c) >1000, ISO 16889). Collapse pressure 21 bar for filters equipped with by-pass valve or 210 bar for filters without by-pass
- without or with differential clogging indicator (electrical or visual).

1 MODEL CODE OF COMPLETE FILTERS

FPH	-	10	-	A	-	F10	-	01	-	R	-	W	**	/	*
In line filter, high pressure													Series number	Seals material: - = NBR PE = FKM (4)	
Filter size: 10 = ports size 3/4" ÷ 1" 30 = ports size 1 1/4" ÷ 1 1/2"													Differential clogging indicator see sect. [9]: W = without, indicator port unplugged P = without, indicator port with steel plug L = electrical indicator with LED (3) M = electrical indicator without LED (3) V = visual indicator (3)		
Filter length:		FPH-10		FPH-30											
A	=	75		175											
B	=	105		260											
C	=	-		310											
D	=	-		340											
Microfibre filtration rating, βx(c) > 1000 - ISO 16889: F03 = 4,5 µm (c) F06 = 7 µm (c) F10 = 12 µm (c)													By-pass: R = by-pass valve with cracking pressure 6 bar (filter element with collapse pressure 21 bar) N = without by-pass (filter element with collapse pressure 210 bar)		
Ports size:													SAE 6000 flange with metric bolts:		
BSPP threaded:													SAE 6000 flange with UNC bolts (2):		
FPH-10				FPH-30				FPH-10				FPH-30			
01 = G 3/4"				03 = G 1 1/4"				21 = 3/4"				23 = 1 1/4"			
02 = G 1"				04 = G 1 1/2"				22 = 1"				24 = 1 1/2"			
SAE J1926-1 threaded (2):															
FPH-10				FPH-30				FPH-10				FPH-30			
42 = SAE-16 (1")				44 = SAE-24 (1 1/2")				32 = 1"				34 = 1 1/2"			

Note: filters for use in potentially explosive atmosphere are available on request, contact Atos Technical Office

- (1) Max flow rates are performed in following conditions:
 - clean filter element
 - filtration rating F10 (12 µm (c))
 - largest port size
 - option /R, filter element with collapse pressure 21 bar
 - Δp = 1 bar
 - mineral oil with viscosity 32 mm²/s
 In case of different conditions the max flow rates have to be recalculated - see section [10]
- (2) Filters with SAE threaded ports and SAE 6000 flange with UNC bolts are available on request
- (3) The clogging indicator is supplied disassembled from the filter. The indicator port on filter head is plugged with plastic plug
- (4) Filters with FKM seals are available on request

2 HYDRAULIC SYMBOLS (representation according to ISO 1219-1)

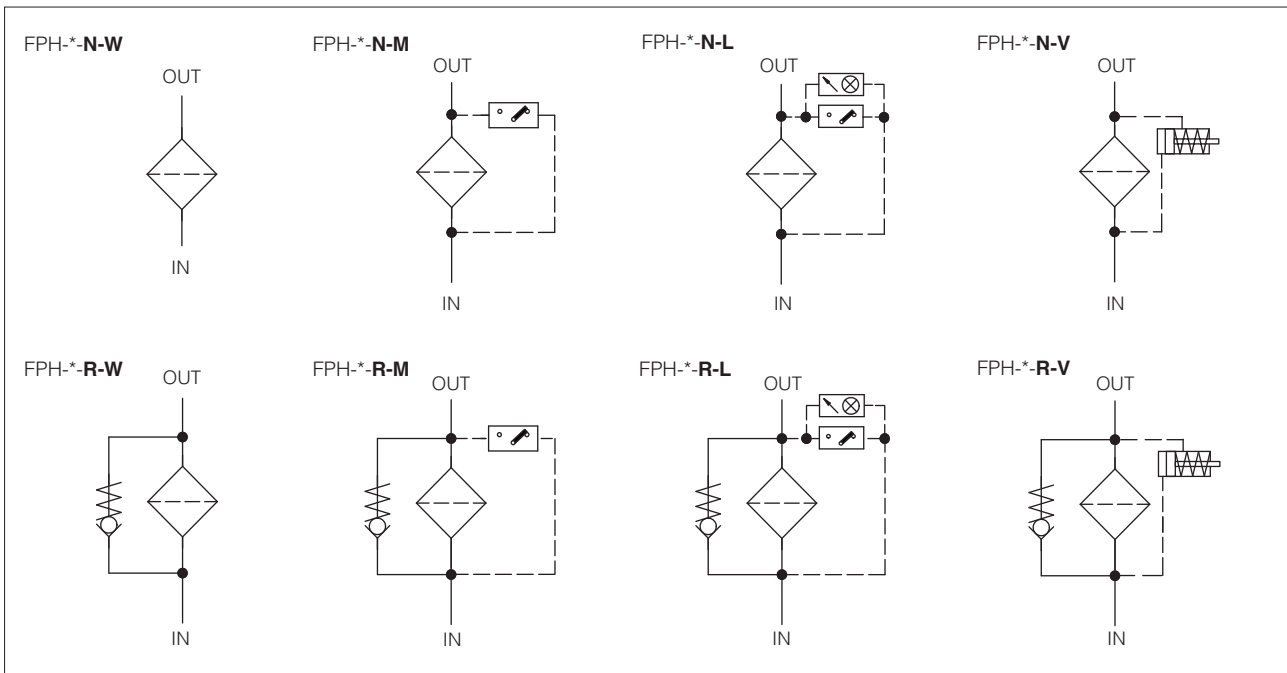

3 MODEL CODE OF FILTER ELEMENTS - only for spare (1)

PSH	-	10	-	A	-	F10	-	R	/	**	/	*
Spare filter element for in line filter type FPH										Series number		Seals material: - = NBR PE = FKM (2)
Filter element size:												
10 = for FPH-10												
30 = for FPH-30												
Filter element length:												
for FPH-10	for FPH-30											
A	A											
B	B											
C	C											
D	D											
		Microfibre filtration rating, $\beta_{x(c)} > 1000$ - ISO 16889:										
		F03 = 4,5 μm (c)										
		F06 = 7 μm (c)										
		F10 = 12 μm (c)										
		R = filter element with collapse pressure 21 bar, for filter FPH-*-R with by-pass valve										
		N = filter element with collapse pressure 210 bar, for filter FPH-*-N without by-pass valve										

(1) Select the filter element according to the model code reported on the filter nameplate, see section 14.1

(2) Filters element with FKM seals are available on request

4 MODEL CODE OF DIFFERENTIAL CLOGGING INDICATORS - only for spare

CID	-	E	-	05	-	M	/	**	/	*	
Spare differential clogging indicator for in line filter								Series number		Seals material: - = NBR PE = FKM	
Type of indicator:											
E = electrical											
V = visual											
Differential switching pressure:											
05 = 5 bar for filters with by-pass valve											
08 = 8 bar for filters without by-pass valve											
		Optional LED - only for CID-E									
		L = with LED									
		M = without LED									

5 GENERAL CHARACTERISTICS

Assembly position / location	Vertical position with the bowl downward	
Ambient temperature range	Standard = -20°C ÷ +70°C / PE option = -20°C ÷ +70°C	
Storage temperature range	Standard = -20°C ÷ +80°C / PE option = -20°C ÷ +80°C	
Materials	Filter head	Cast iron
	Filter bowl	Steel
Surface protection	Phosphatized	
Fatigue strength	min. 1 x 10 ⁶ cycles at 420 bar	

6 HYDRAULICS CHARACTERISTICS

Filter size	10						30					
	01	21	02	22	32	42	03	23	04	24	34	44
Port size code												
Ports dimensions: BSPP threaded	G3/4"		G1"				G1 1/4"		G1 1/2"			
SAE J1926-1 threaded						SAE-16						SAE-24
SAE 6000 with metric bolts		3/4"		1"				1 1/4"		1 1/2"		
SAE 6000 with UNC bolts					1"						1 1/2"	
Max operating pressure (bar)	420											
Max flow (1) R = filter with by-pass	65 ÷ 80			75 ÷ 105			165 ÷ 300			170 ÷ 330		
(l/min) N = filter without by-pass	55 ÷ 70			65 ÷ 90			145 ÷ 245			150 ÷ 260		
Direction of filtration	See the arrow on the filter head											
(1) Max flow rates are performed in following conditions:												
- clean filter element - filtration rating F10 (12 µm (c)) - Δp 1 bar - min ÷ max filter length - mineral oil with viscosity 32 mm ² /s												
In case of different conditions the max flow rates have to be recalculated - see section 10												

7 FILTER ELEMENTS

Material		Inorganic microfibre
Filtration rating as per ISO16889	F03	β _{4,5µm (c)} ≥ 1000
	F06	β _{7,5µm (c)} ≥ 1000
	F10	β _{12µm (c)} ≥ 1000
Filter element collapse pressure	R = for filter with by-pass valve N = for filter without by-pass valve	21 bar 210 bar

8 SEALS AND HYDRAULIC FLUIDS - for other fluids not included in below table, consult our technical office

Seals, recommended fluid temperature	NBR seals (standard) = -25°C ÷ +100°C, with HFC hydraulic fluids = +10°C ÷ +50°C FKM seals (/PE option) = -25°C ÷ +100°C		
Recommended viscosity	15 ÷ 100 mm ² /s - max allowed range 2.8 ÷ 500 mm ² /s		
Hydraulic fluid	Suitable seals type	Classification	Ref. Standard
Mineral oils	NBR, FKM	HL, HLP, HLPD, HVL, HVLDP	DIN 51524
Flame resistant without water	FKM	HFDU, HFDR	ISO 12922
Flame resistant with water	NBR	HFC	

9 DIFFERENTIAL CLOGGING INDICATORS

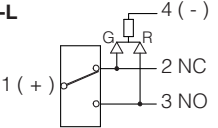
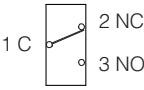
Model code	CID-E* ELECTRICAL		CID-V* VISUAL
Differential switching pressure	CID-E05, CID-V05	5 bar ± 10%	5 bar ± 15%
	CID-E08, CID-V08	8 bar ± 10%	8 bar ± 10%
Max pressure	450 bar		420 bar
Max differential pressure	200 bar		
Ambient temperature	-25°C ÷ +100°C		-25°C ÷ +80°C
Hydraulic connection	M20x1,5		
Duty factor	100%		
Mechanical life	1 x 10 ⁶ operations		
Mass (Kg)	0,16		0,11
Electric connection	Electric plug connection as per DIN 43650 with cable gland type PG7		
Power supply	CID-E05-L, CID-E08-L	24 V _{DC} ± 10%	
	CID-E05-M, CID-E08-M	14 V _{DC} ÷ 30 V _{DC}	125 V _{AC} ÷ 250 V _{AC}
Max current - resistive (inductive)	5 A (4 A) ÷ 4 A (3 A)	5 A (3 A) ÷ 3 A (2 A)	
Protection degree to DIN EN 60529	IP65 with mating connector		
Electric scheme shown with switch position in case of clean filter element	CID*-L		CID*-M
			

10 FILTERS SIZING

For the filter sizing it is necessary to consider the Total Δp at the maximum flow at which the filter must work.
The Total Δp is given by the sum of filter head Δp plus the filter element Δp :

$$\text{Total } \Delta p = \text{filter head } \Delta p + \text{filter element } \Delta p$$

In the best conditions the total Δp should not exceed 1,0 bar
See below sections to calculate the Δp of filter head and Δp of the filter element

10.1 Q/ Δp DIAGRAMS OF FILTER HEAD

The pressure drop of filter head mainly depends on the ports size and fluid density

In the following diagrams are reported the Δp characteristics of filter head based on mineral oil with density 0,86 kg/dm³ and viscosity 30 mm²/s

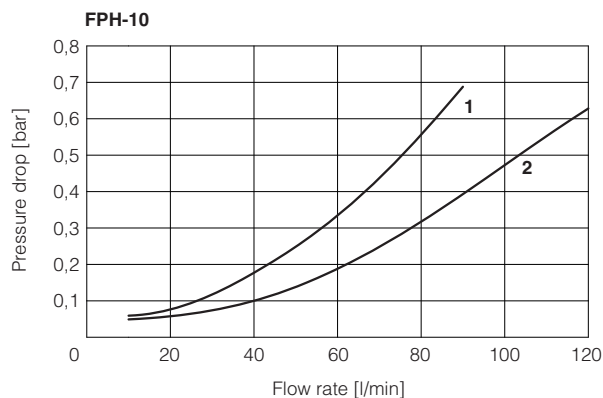

1 = FPH-10*** 01 (G 3/4")
FPH-10*** 21 (3/4" SAE 6000)

2 = FPH-10*** 02 (G 1")
FPH-10*** 22 (1" SAE 6000)
FPH-10*** 32 (1" SAE 6000)
FPH-10*** 42 (1" SAE-16)

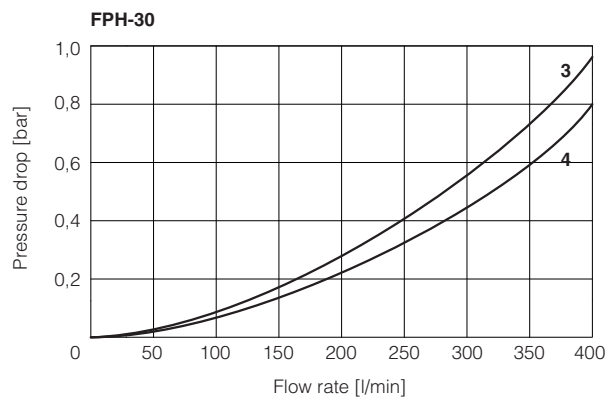

3 = FPH-30*** 03 (G 1 1/4")
FPH-30*** 23 (1 1/4" SAE 6000)

4 = FPH-30*** 04 (G 1 1/2")
FPH-30*** 24 (G 1 1/2" SAE 6000)
FPH-30*** 34 (G 1 1/2" SAE 6000)
FPH-30*** 44 (SAE-24)

10.2 FILTER ELEMENT Δp

The pressure drop through the filter depends to:

- size of filter element
- filtration rating
- fluid viscosity

The Δp of filter element is given by the formula:

$$\Delta p \text{ of filter element} = Q \times \frac{Gc}{1000} \times \frac{\text{Viscosity}}{30}$$

Q = working flow (l/min)

Gc = Gradient coefficient (mbar/(l/min)). The Gc values are reported in the following table

Viscosity = effective fluid viscosity in the working conditions (mm²/s)

Gradient coefficient Gc of PSH filter elements

Filter element size		10		30			
Filter element lenght		A	B	A	B	C	D
Filter element type	Filtration rating	Gc Gradient coefficient					
R for filter with bypass valve	F03	27.75	15.25	14	7.13	4.7	3.62
	F06	15.12	7.58	8.03	3.37	2.2	1.89
	F10	9.37	4.91	4.43	2.33	1.5	1.12
N for filter without bypass valve	F03	32.2	17.32	16.48	8.13	5.5	4.71
	F06	22.38	9.41	11.88	4.18	3.28	2.91
	F10	11.2	6.27	5.27	3.45	2.36	2.15

Example:

calculation of Total Δp for filter type FPH-30-C-F06-04-R at Q = 200 l/min and viscosity 46 mm²/s (filter element PSH-30-C-F06-R)

Δp of filter head = 0,22 bar

Gr = 2,2 mbar/(l/min)

$$\text{Filter element } \Delta p = 200 \times \frac{2,2}{1000} \times \frac{46}{30} = 0,68 \text{ bar}$$

Total Δp = 0,22 + 0,68 = 0,90 bar

11 INSTALLATION DIMENSIONS OF FPH FILTERS [mm]

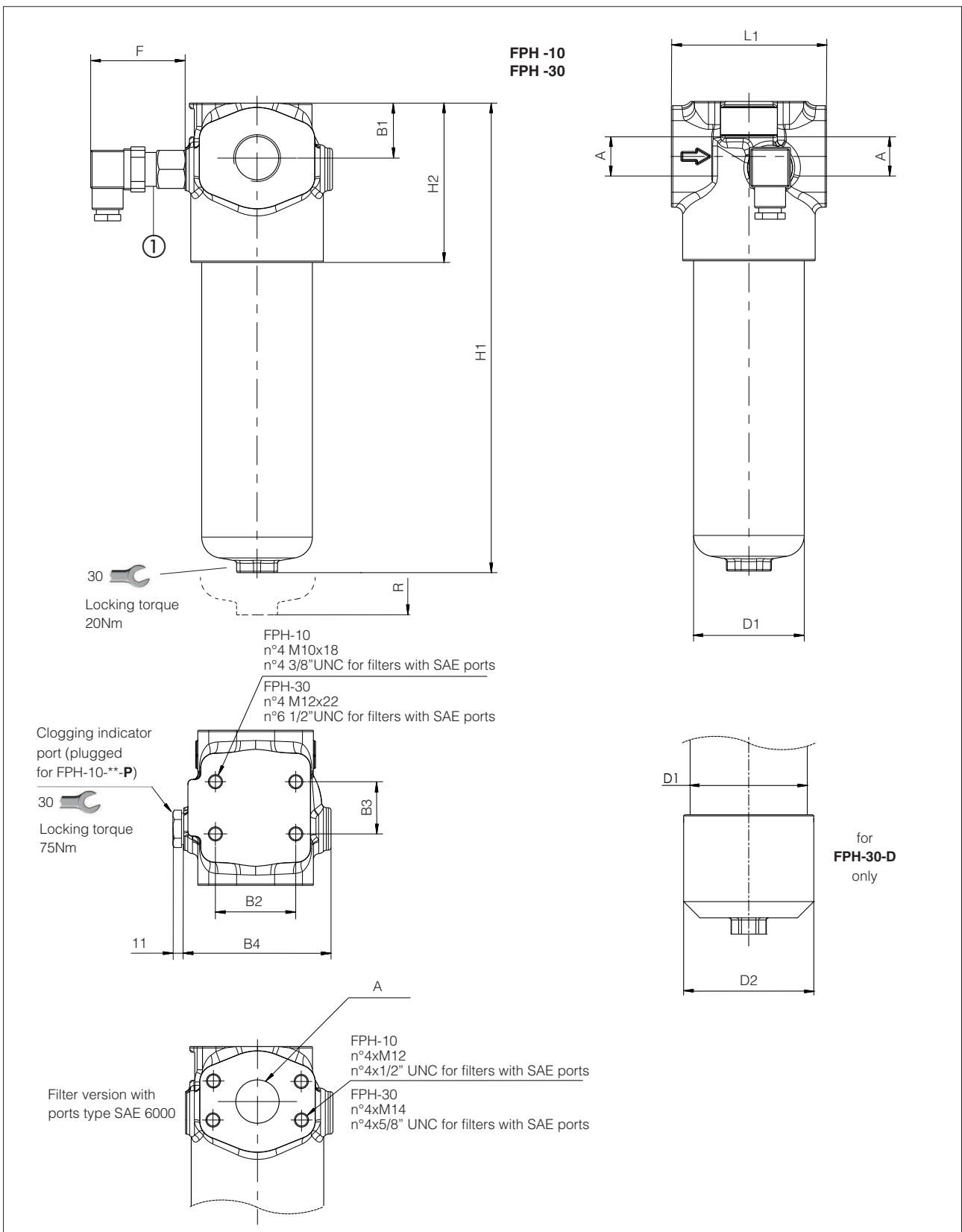

① Optional differential clogging indicator. The drawing shows the electrical indicator type CIA-E*

Code	A	B1	B2	B3	B4	D1	D2	F	H1	H2	L1	R	Mass (Kg)
FPH-10-A	see sect. 6 for available port size	39	57	37	105	78,5	-	68	222	113	110	130	6,7
FPH-10-B									333				8,4
FPH-30-A		47	76	64	140	107			262	13,2			
FPH-30-B									355	15,5			
FPH-30-C									475	18,4			
FPH-30-D									568	22,8			

12 DIMENSIONS OF DIFFERENTIAL CLOGGING INDICATORS

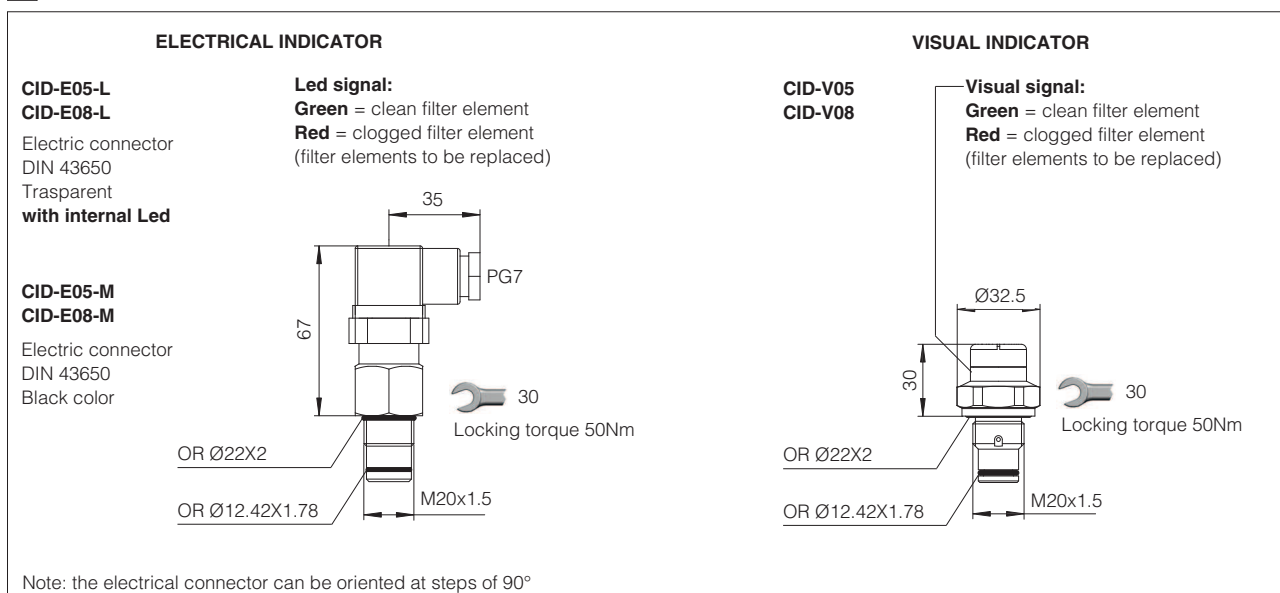

13 INSTALLATION AND COMMISSIONING

The max operating pressure of the system must not exceed the max working pressure of the filter. During the filter installation, pay attention to respect the flow direction, shown by the arrow on the filter head. The filter should be preferably mounted with the housing downward. The filter head should be properly secured using the threaded fixing holes on the filter head. Make sure that there is enough space for the replacement of the filter element. Never run the system without the filter element. For filters ordered with clogging indicator:

- remove the plastic plug from the indicator port on the filter head
- install the clogging indicator and lock it at the specified torque

During the cold start up (fluid temperature lower than 30°C), a false clogging indicator signal can be given due to the high fluid viscosity.

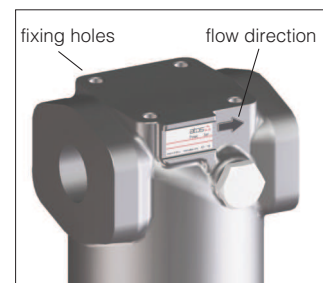

14 MAINTENANCE

The filter element must be replaced as soon as the clogging indicator switches to highlight the filter clogged condition. For filters without clogging indicator, the filter element must be replaced according to the system manufacturer's recommendations. Select the new filter element according to the model code reported on the filter nameplate, see section 14.1. For the replacement of the filter element, proceed as follow:

- releases the system pressure; the filter has no pressure bleeding device
- pay attention to the fluid and filter surface temperature. Always use suitable gloves and protection glasses
- unscrew the bowl ② from the filter head ① by turning counterclockwise (view from bottom side)
- remove the dirty filter element ③ pulling it carefully
- lubricate the seal of new filter element and insert it over the spigot in the filter head
- clean the bowl internally, lubricate the threads and screw by hand the bowl to the filter head by turning clockwise (view from bottom side). Tighten at the recommended torque.

WARNING: The dirty filter elements cannot be cleaned and re-used. They are classified as "dangerous waste material", then they must be disposed of by authorized Companies, according to the local laws.

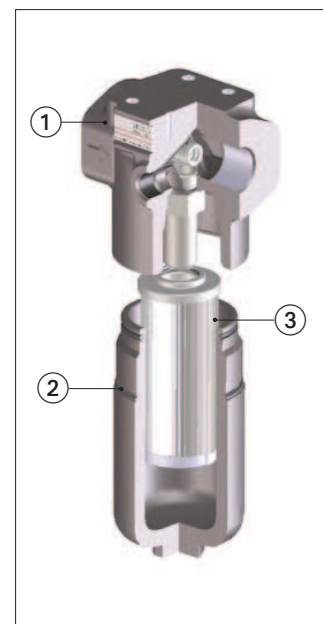

14.1 FILTER IDENTIFICATION NAMEPLATE

