

Ex-proof digital servoproportional 3-way cartridges

piloted, with on-board driver and two LVDT transducers - ATEX and IECEx

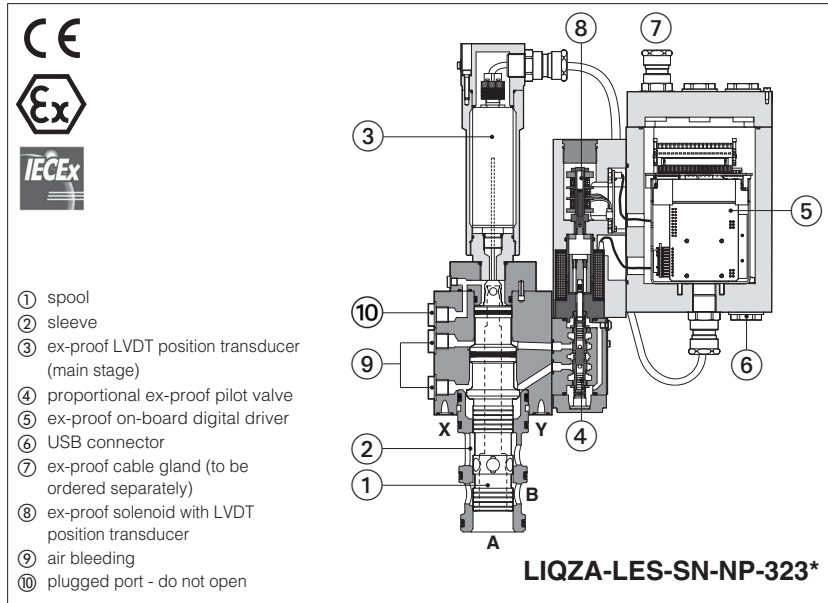

LIQZA-LES

Ex-proof digital servoproportional 3-way cartridges, with two LVDT position transducers (pilot valve and main stage) for best accuracy in directional controls and in not compensated flow regulations.

They are equipped with ex-proof on-board digital driver, LVDT transducers and proportional solenoid certified for safe operations in hazardous environments with potentially explosive atmosphere.

- Multicertification **ATEX** and **IECEx** for gas group **II 2G** and dust category **II 2D**

The flameproof enclosure of on-board digital driver, solenoid and transducer, prevents the propagation of accidental internal sparks or fire to the external environment.

The driver and solenoid are also designed to limit the surface temperature within the classified limits.

Size: **25 ÷ 80** - not ISO cavity

Max flow: **500 ÷ 5000 l/min**

Max pressure: **420 bar**

1 MODEL CODE

LIQZA	-	LES	-	SN	-	NP	-	32	3	L4	/	M	/	*	*	/	*
Ex-proof proportional cartridge																	Seals material, see section 9: - = NBR PE = FKM BT = HNBR

Ex-proof proportional cartridge

LES = on-board driver and two LVDT transducers

Alternated P/Q controls:

- SN** = none
- SP** = pressure control (1 pressure transducer)
- SL** = force control (1 load cell)

Fieldbus interfaces, USB port always present:

- NP** = Not present
- BC** = CANopen
- BP** = PROFIBUS DP
- EH** = EtherCAT
- EW** = POWERLINK
- EI** = EtherNet/IP
- EP** = PROFINET RT/IRT

Valve size and nominal flow (l/min) at Δp 5 bar:

- 25** = 185
- 32** = 330
- 40** = 420
- 50** = 780
- 63** = 1250
- 80** = 2100

Hydraulic options (1):

A = reversal hydraulic configuration of main spool: P-A in rest position

Electronic options (1):

- C** = current feedback for pressure transducer 4÷20mA (omit for std voltage ±10Vdc) only for **SP, SL**
- I** = current reference input and monitor 4÷20mA (omit for std voltage ±10Vdc)

Cable entrance threaded connection:

M = M20X1,5

Spool type ,regulating characteristics:



Configuration: 3 = 3 way

functional symbol: **Standard**

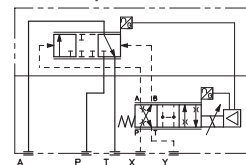

simplified symbol: **Standard**

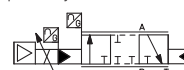

option **/A**

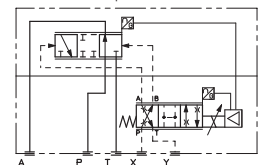

option **/A**

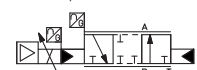

(1) For possible combined options, see section 15

2 GENERAL NOTES

Atos digital proportionals valves are CE marked according to the applicable directives (e.g. Immunity and Emission EMC Directive). Installation, wirings and start-up procedures must be performed according to the general prescriptions shown in tech table **FX900** and in the user manuals included in the E-SW-* programming software.

3 VALVE SETTINGS AND PROGRAMMING TOOLS

WARNING: the below operation must be performed in a safety area

Valve's functional parameters and configurations, can be easily set and optimized using Atos E-SW programming software connected via USB port to the digital driver (see table **GS003**). For fieldbus versions, the software permits valve's parameterization through USB port also if the driver is connected to the central machine unit via fieldbus.

The software is available in different versions according to the driver's options (see table **GS500**):

E-SW-BASIC support: NP (USB) PS (Serial) IR (Infrared)
E-SW-FIELDBUS support: BC (CANopen) BP (PROFIBUS DP) EH (EtherCAT)
 EW (POWERLINK) EI (EtherNet/IP) EP (PROFINET)
E-SW-*/PQ support: valves with SP, SF, SL alternated control (e.g. E-SW-BASIC/PQ)

WARNING: drivers USB port is not isolated! For E-C-SB-USB/M12 cable, the use of isolator adapter is highly recommended for PC protection

WARNING: Bluetooth adapter is available only for European, USA and Canadian markets! Bluetooth adapter is certified according RED (Europe), FCC (USA) and ISED (Canada) directives

USB or Bluetooth connection

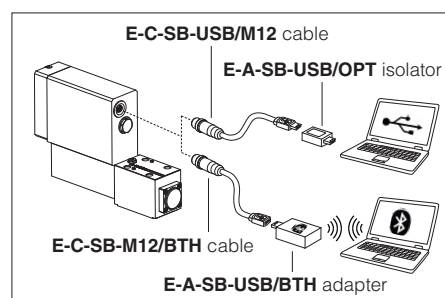

4 FIELDBUS - see tech. table **GS510**

Fieldbus allows valve direct communication with machine control unit for digital reference, valve diagnostics and settings. These execution allow to operate the valves through fieldbus or analog signals available on the main connector.

5 ALTERNATED P/Q CONTROLS - see tech. table **FX500**

S* options add the closed loop control of pressure (**SP**) or force (**SL**) to the basic functions of proportional directional valves flow regulation. A dedicated algorithm alternates pressure (force) depending on the actual hydraulic system conditions. An additional connector is available for transducers to be interfaced to the valve's driver (1 pressure transducer for SP or 1 load cell for SL). The alternated pressure control (SP) is possible only for specific installation conditions.

6 GENERAL CHARACTERISTICS

Assembly position	Any position
Subplate surface finishing to ISO 4401	Acceptable roughness index, Ra ≤0,8 recommended Ra 0,4 - flatness ratio 0,01/100
MTTFd valves according to EN ISO 13849	75 years, see technical table P007
Ambient temperature range	Standard = -20°C ÷ +60°C /PE option = -20°C ÷ +60°C /BT option = -40°C ÷ +60°C
Storage temperature range	Standard = -20°C ÷ +70°C /PE option = -20°C ÷ +70°C /BT option = -40°C ÷ +70°C
Surface protection	Zinc coating with black passivation - salt spray test (EN ISO 9227) > 200 h
Compliance	Explosion proof protection, see section 10 -Flame proof enclosure "Ex d" -Dust ignition protection by enclosure "Ex t" RoHs Directive 2011/65/EU as last update by 2015/65/EU REACH Regulation (EC) n°1907/2006

7 HYDRAULIC CHARACTERISTICS - based on mineral oil ISO VG 46 at 50 °C

	25	32	40	50	63	80
Max regulated flow [l/min]						
Δp P-A or A-T at Δp = 5 bar	185	330	420	780	1250	2100
at Δp = 10 bar	260	470	590	1100	1750	3000
Max permissible flow	500	850	1050	2000	3100	5000
Max pressure [bar]	Ports P, A, T = 420 X = 350 Y ≤ 10					
Nominal flow of pilot valve at Δp = 70 bar [l/min]	4	8	28	40	100	100
Leakage of pilot valve at P = 100 bar [l/min]	0,2	0,2	0,5	0,7	0,7	0,7
Piloting pressure [bar]	min: 40% of system pressure max 350 recommended 140 ÷ 160					
Piloting volume [cm³]	2,16	7,2	8,9	17,7	33,8	42,7
Piloting flow (1) [l/min]	6,5	20	25	43	68	76
Response time (2) [ms]	≤ 25	≤ 27	≤ 27	≤ 30	≤ 35	≤ 40
Hysteresis [% of the max regulation]	≤ 0,1					
Repeatability [% of the max regulation]	± 0,1					
Thermal drift	zero point displacement < 1% at ΔT = 40°C					

(1) 0÷100% step signal

(2) With pilot pressure = 140 bar

WARNING

The loss of the pilot pressure causes the undefined position of the main spool.

The sudden interruption of the power supply during the valve operation causes the immediate main spool opening A → T or P → A (for option /A). This could cause pressure surges in the hydraulic system or high decelerations which may lead to machine damages.

8 ELECTRICAL CHARACTERISTICS

Power supplies	Nominal : +24 VDC Rectified and filtered : VRMS = 20 ÷ 32 VMAX (ripple max 10 % VPP)		
Max power consumption	35 W		
Analog input signals	Voltage: range ±10 VDC (24 VMAX tollerant) Current: range ±20 mA		Input impedance: Ri > 50 kΩ Input impedance: Ri = 500 Ω
Insulation class	H (180°) Due to the occuring surface temperatures of the solenoid coils, the European standards ISO 13732-1 and EN982 must be taken into account		
Monitor outputs	Output range: voltage ±10 Vdc @ max 5 mA current ±20 mA @ max 500 Ω load resistance		
Enable input	Range: 0 ÷ 5 Vdc (OFF state), 9 ÷ 24 VDC (ON state), 5 ÷ 9 VDC (not accepted); Input impedance: Ri > 10 kΩ		
Fault output	Output range: 0 ÷ 24 Vdc (ON state > [power supply - 2 V] ; OFF state < 1 V) @ max 50 mA; external negative voltage not allowed (e.g. due to inductive loads)		
Pressure/force transducer power supply (only for SP, SL)	+24VDC @ max 100 mA (E-ATRA-7 see tech table GX800)		
Alarms	Solenoid not connected/short circuit, cable break with current reference signal, over/under temperature, valve spool transducer malfunctions		
Protection degree to DIN EN60529	IP66/67 with relevant cable gland		
Duty factor	Continuous rating (ED=100%)		
Tropicalization	Tropical coating on electronics PCB		
Additional characteristics	Short circuit protection of solenoid current supply; spool position control (SN) or pressure/force control (SP, SL) by P.I.D. with rapid solenoid switching; protection against reverse polarity of power supply		
Electromagnetic compatibility (EMC)	According to Directive 2014/30/UE (Immunity: EN 61000-6-2; Emission: EN 61000-6-3)		
Communication interface	USB	CANopen	PROFIBUS DP
	Atos ASCII coding	EN50325-4 + DS408	EN50170-2/IEC61158
Communication physical layer	not insulated	optical insulated	optical insulated
	USB 2.0 + USB OTG	CAN ISO11898	RS485
			EtherCAT, POWERLINK, EtherNet/IP, PROFINET IO RT / IRT EC 61158 Fast Ethernet, insulated 100 Base TX

Note: a maximum time of 800 ms (depending on communication type) have be considered between the driver energizing with the 24 Vdc power supply and when the valve is ready to operate. During this time the current to the valve coils is switched to zero

9 SEALS AND HYDRAULIC FLUIDS - for other fluids not included in below table, consult our technical office

Seals, recommended fluid temperature	NBR seals (standard) = -20°C ÷ +60°C, with HFC hydraulic fluids = -20°C ÷ +50°C FKM seals (PE option) = -20°C ÷ +80°C HNBR seals (/BT option) = -40°C ÷ +60°C, with HFC hydraulic fluids = -40°C ÷ +50°C		
Recommended viscosity	20 ÷ 100 mm ² /s - max allowed range 15 ÷ 380 mm ² /s		
Max fluid contamination level	normal operation	ISO4406 class 18/16/13 NAS1638 class 7	see also filter section at www.atos.com or KTF catalog
	longer life	ISO4406 class 16/14/11 NAS1638 class 5	
Hydraulic fluid	Suitable seals type	Classification	Ref. Standard
Mineral oils	NBR, FKM, HNBR	HL, HLP, HLPD, HVLP, HVLPD	DIN 51524
Flame resistant without water	FKM	HFDU, HFDR	ISO 12922
Flame resistant with water (1)	NBR, HNBR	HFC	

 The ignition temperature of the hydraulic fluid must be 50°C higher than the max solenoid surface temperature

(1) Performance limitations in case of flame resistant fluids with water:

- max operating pressure = 210 bar
- max fluid temperature = 50°C

10 CERTIFICATION DATA

Components type	Pilot valve solenoid and LVDT transducer		LVDT main stage transducer
Certifications	Multicertification ATEX IECEx		
Components Certified code	OZA-LES		ETHA-15
Type examination certificate (1)	<ul style="list-style-type: none"> • ATEX: TUV IT 18 ATEX 068 X • IECEx: IECEx TPS 19.0004X 		<ul style="list-style-type: none"> • ATEX: TUV IT 16 ATEX 053 X • IECEx: IECEx TPS 16.0003X
Method of protection	<ul style="list-style-type: none"> • ATEX Ex II 2G Ex db IIC T6/T5/T4 Gb Ex II 2D Ex tb IIIC T85°C/T100°C/T135°C Db 		<ul style="list-style-type: none"> • IECEx Ex db IIC T6/T5/T4 Gb Ex tb IIIC T85°C/T100°C/T135°C Db
Temperature class	T6	T5	T4
Surface temperature	≤ 85 °C	≤ 100 °C	≤ 135 °C
Ambient temperature (2)	-40 ÷ +40 °C	-40 ÷ +55 °C	-40 ÷ +70 °C
Applicable Standards	EN 60079-0 EN 60079-1	EN 60079-31	IEC 60079-0 IEC 60079-1
Cable entrance: threaded connection	M = M20x1,5		factory wired

(1) The type examiner certificates can be downloaded from www.atos.com

(2) The driver solenoid and LVDT transducers are certified for minimum ambient temperature -40°C.

In case the complete valve must withstand with minimum ambient temperature -40°C, select **/BT** in the model code.

 **WARNING: service work performed on the valve by the end users or not qualified personnel invalidates the certification**

11 CABLE SPECIFICATION AND TEMPERATURE - Power supply and grounding cables have to comply with following characteristics:

Power supply and signals: section of wire = 1,0 mm ²	Grounding: section of external ground wire = 4 mm ²
--	---

11.1 Cable temperature

The cable must be suitable for the working temperature as specified in the "safety instructions" delivered with the first supply of the products.

Max ambient temperature [°C]	Temperature class	Max surface temperature [°C]	Min. cable temperature [°C]
40 °C	T6	85 °C	80 °C
55 °C	T5	100 °C	90 °C
70 °C	T4	135 °C	110 °C

12 CABLE GLANDS

Cable glands with threaded connections M20x1,5 for standard or armoured cables have to be ordered separately, see tech table **KX800**

Note: a Loctite sealant type 545, should be used on the cable gland entry threads

13 HYDRAULIC OPTIONS

- A** = The standard valve version provides the hydraulic configuration A-T of main spool in absence of electric power supply to the valve.
The option /A provides the reverse configuration P-A of main spool in absence of electric power supply to the valve.
This execution is particularly requested in vertical presses for safety reasons, because in case of electric power breakdown the P-A configuration of the main spool prevents the uncontrolled and dangerous downstroke of the press ram.

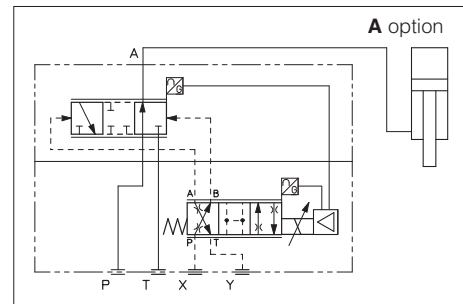

14 ELECTRONICS OPTIONS

- I** = This option provides 4 ÷ 20 mA current reference and monitor signals, instead of the standard 0 ÷ 10 VDC.
Input signal can be reconfigured via software selecting between voltage and current, within a maximum range of ±10 VDC or ±20 mA.
It is normally used in case of long distance between the machine control unit and the valve or where the reference signal can be affected by electrical noise; the valve functioning is disabled in case of reference signal cable breakage.
- C** = Only for **SP, SL**
This option is available to connect pressure (force) transducers with 4 ÷ 20 mA current output signal, instead of the standard ±10 VDC.
Input signal can be reconfigured via software selecting between voltage and current, within a maximum range of ±10 VDC or ±20 mA.

15 POSSIBLE COMBINED OPTIONS

For **SN**: /AI
For **SP, SL**: /AC, AI, /CI, /ACI

16 DIAGRAMS (based on mineral oil ISO VG 46 at 50 °C)

16.1 Regulation diagrams, see note

1 = LIQZA (all sizes)

Hydraulic configuration vs. reference signal:

	standard	option /A
Reference signal 0 ÷ +10 V } P → A		A → T
12 ÷ 20 mA } P → A		A → T
Reference signal 0 ÷ -10 V } A → T		P → A
4 ÷ 12 mA } A → T		P → A

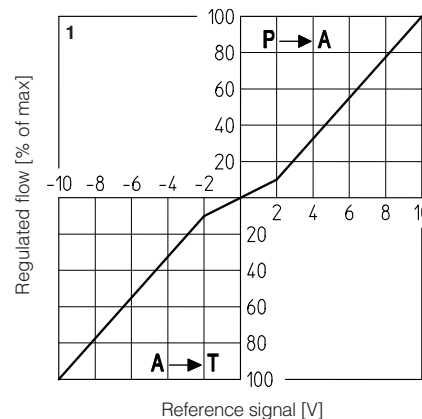

17 POWER SUPPLY AND SIGNALS SPECIFICATIONS

Generic electrical output signals of the valve (e.g. fault or monitor signals) must not be directly used to activate safety functions, like to switch-ON/OFF the machine's safety components, as prescribed by the European standards (Safety requirements of fluid technology systems and components-hydraulics, EN-982).

17.1 Power supply (V+ and V0)

The power supply must be appropriately stabilized or rectified and filtered: apply at least a 10000 μ F/40 V capacitance to single phase rectifiers or a 4700 μ F/40 V capacitance to three phase rectifiers.

 A safety fuse is required in series to each power supply: 2,5 A time lag fuse.

17.2 Power supply for driver's logic and communication (VL+ and VL0)

The power supply for driver's logic and communication must be appropriately stabilized or rectified and filtered: apply at least a 10000 μ F/40 V capacitance to single phase rectifiers or a 4700 μ F/40 V capacitance to three phase rectifiers.

The separate power supply for driver's logic on pin 3 and 4, allow to remove solenoid power supply from pin 1 and 2 maintaining active the diagnostics, USB and fieldbus communications.

 A safety fuse is required in series to each driver's logic and communication power supply: 500 mA fast fuse.

17.3 Flow reference input signal (Q_INPUT+)

The driver controls in closed loop the valve spool position proportionally to the external reference input signal.

Reference input signal is factory preset according to selected valve code, defaults are ± 10 VDC for standard and $4 \div 20$ mA for /I option.

Input signal can be reconfigured via software selecting between voltage and current, within a maximum range of ± 10 VDC or ± 20 mA.

Drivers with fieldbus interface can be software set to receive reference signal directly from the machine control unit (fieldbus reference).

Analog reference input signal can be used as on-off commands with input range $0 \div 24$ VDC.

17.4 Pressure or force reference input signal (F_INPUT+) - only SP, SL

Functionality of F_INPUT+ signal (pin 12), is used as reference for the driver pressure/force closed loop (see tech. table FX500).

Reference input signal is factory preset according to selected valve code, defaults are ± 10 VDC for standard and $4 \div 20$ mA for /I option.

Input signal can be reconfigured via software selecting between voltage and current, within a maximum range of ± 10 VDC or ± 20 mA.

Drivers with fieldbus interface can be software set to receive reference signal directly by the machine control unit (fieldbus reference).

Analog reference input signal can be used as on-off commands with input range $0 \div 24$ VDC.

17.5 Flow monitor output signal (Q_MONITOR)

The driver generates an analog output signal proportional to the actual spool position of the valve; the monitor output signal can be software set to show other signals available in the driver (e.g. analog reference, fieldbus reference, pilot spool position).

Monitor output signal is factory preset according to selected valve code, defaults are ± 10 VDC for standard and $4 \div 20$ mA for /I option.

Output signal can be reconfigured via software selecting between voltage and current, within a maximum range of ± 10 VDC or ± 20 mA.

17.6 Pressure or force monitor output signal (F_MONITOR) - only for SP, SL

The driver generates an analog output signal proportional to alternated pressure/force control; the monitor output signal can be software set to show other signals available in the driver (e.g. analog reference, force reference).

Monitor output signal is factory preset according to selected valve code, defaults are ± 10 VDC for standard and $4 \div 20$ mA for /I option.

Output signal can be reconfigured via software selecting between voltage and current, within a maximum range of ± 10 VDC or ± 20 mA.

17.7 Enable input signal (ENABLE)

To enable the driver, supply a 24 VDC on pin 6: Enable input signal allows to enable/disable the current supply to the solenoid, without removing the electrical power supply to the driver; it is used to active the communication and the other driver functions when the valve must be disabled for safety reasons. This condition **does not comply** with norms IEC 61508 and ISO 13849.

Enable input signal can be used as generic digital input by software selection.

17.8 Fault output signal (FAULT)

Fault output signal indicates fault conditions of the driver (solenoid short circuits/not connected, reference signal cable broken for $4 \div 20$ mA input, spool position transducer cable broken, etc.). Fault presence corresponds to 0 VDC, normal working corresponds to 24 Vdc.

Fault status is not affected by the Enable input signal. Fault output signal can be used as digital output by software selection.

17.9 Remote pressure/force transducer input signal - only for SP, SL

Analog remote pressure transducers or load cell can be directly connected to the driver.

Analog input signal is factory preset according to selected valve code, defaults are ± 10 VDC for standard and $4 \div 20$ mA for /C option.

Input signal can be reconfigured via software selecting between voltage and current, within a maximum range of ± 10 VDC or ± 20 mA.

Refer to pressure/force transducer characteristics to select the transducer type according to specific application requirements (see table FX500).

18 TERMINAL BOARD OVERVIEW

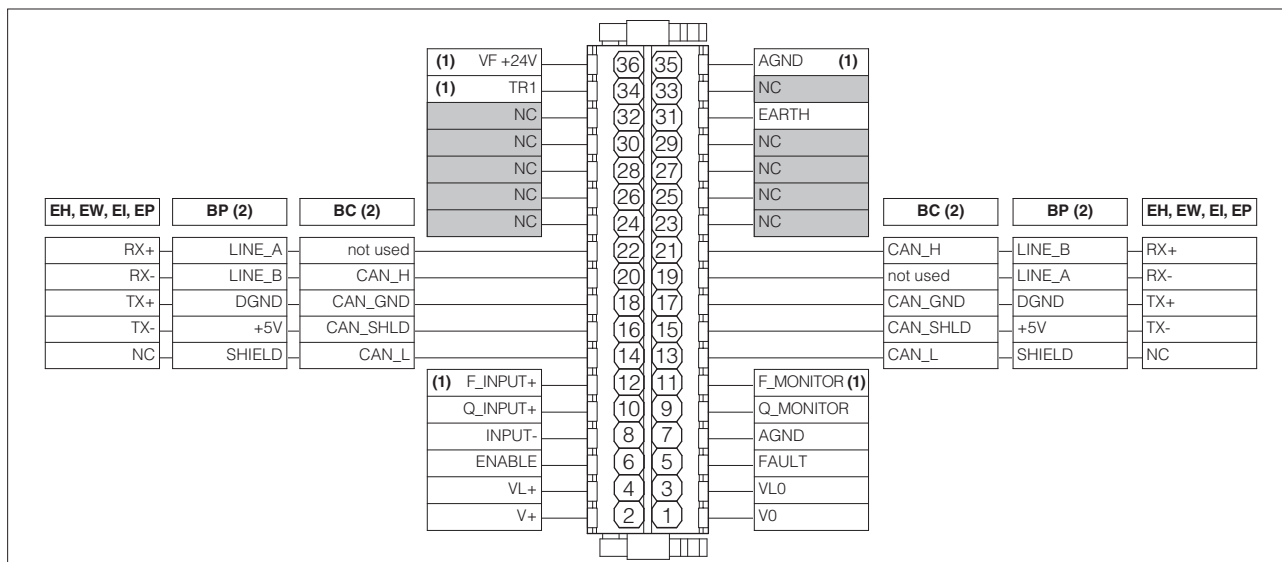

(1) Connections available only SP, SL

(2) For BC and BP executions the fieldbus connections have an internal pass-through connection

19 ELECTRONIC CONNECTIONS

19.1 Main connections signals

CABLE ENTRANCE	PIN	SIGNAL	TECHNICAL SPECIFICATIONS	NOTES
A	1	V0	Power supply 0 Vdc	Gnd - power supply
	2	V+	Power supply 24 Vdc	Input - power supply
	3	VL0	Power supply 0 Vdc for driver's logic and communication	Gnd - power supply
	4	VL+	Power supply 24 Vdc for driver's logic and communication	Input - power supply
	5	FAULT	Fault (0 Vdc) or normal working (24 Vdc), referred to VL0	Output - on/off signal
	6	ENABLE	Enable (24 Vdc) or disable (0 Vdc) the driver, referred to VL0	Input - on/off signal
	7	AGND	Analog ground	Gnd - analog signal
	8	INPUT-	Negative reference input signal for Q_INPUT+ and F_INPUT+	Input - analog signal
	9	Q_MONITOR	Flow monitor output signal: ± 10 Vdc / ± 20 mA maximum range, referred to AGND Defaults are: ± 10 Vdc for standard and $4 \div 20$ mA for /I option	Output - analog signal Software selectable
	10	Q_INPUT+	Flow reference input signal: ± 10 Vdc / ± 20 mA maximum range Defaults are: ± 10 Vdc for standard and $4 \div 20$ mA for /I option	Input - analog signal Software selectable
	11	F_MONITOR	Pressure/Force monitor output signal: ± 10 Vdc / ± 20 mA maximum range, referred to AGND (1) Defaults are: ± 10 Vdc for standard and $4 \div 20$ mA for /I option	Output - analog signal Software selectable
	12	F_INPUT+	Pressure/Force reference input signal: ± 10 Vdc / ± 20 mA maximum range (1) Defaults are: ± 10 Vdc for standard and $4 \div 20$ mA for /I option	Input - analog signal Software selectable
31	EARTH	Internally connected to driver housing		

(1) Available only for **SP, SL**

19.2 USB connector - M12 - 5 pin always present

CABLE ENTRANCE	PIN	SIGNAL	TECHNICAL SPECIFICATIONS	Driver view	
B	1	+5V_USB	Power supply		
	2	ID	Identification		
	3	GND_USB	Signal zero data line		
	4	D-	Data line -		
	5	D+	Data line +		

19.3 BC fieldbus execution connections

CABLE ENTRANCE	PIN	SIGNAL	TECHNICAL SPECIFICATIONS	CABLE ENTRANCE	PIN	SIGNAL	TECHNICAL SPECIFICATIONS
C1	14	CAN_L	Bus line (low)	C2	13	CAN_L	Bus line (low)
	16	CAN_SHLD	Shield		15	CAN_SHLD	Shield
	18	CAN_GND	Signal zero data line		17	CAN_GND	Signal zero data line
	20	CAN_H	Bus line (high)		19	not used	Pass-through connection (1)
	22	not used	Pass-through connection (1)		21	CAN_H	Bus line (high)

(1) Pin 19 and 22 can be fed with external +5V supply of CAN interface

19.4 BP fieldbus execution connections

CABLE ENTRANCE	PIN	SIGNAL	TECHNICAL SPECIFICATIONS	CABLE ENTRANCE	PIN	SIGNAL	TECHNICAL SPECIFICATIONS
C1	14	SHIELD		C2	13	SHIELD	
	16	+5V	Power supply		15	+5V	Power supply
	18	DGND	Data line and termination signal zero		17	DGND	Data line and termination signal zero
	20	LINE_B	Bus line (low)		19	LINE_A	Bus line (high)
	22	LINE_A	Bus line (high)		21	LINE_B	Bus line (low)

19.5 EH, EW, EI, EP fieldbus execution connections

CABLE ENTRANCE	PIN	SIGNAL	TECHNICAL SPECIFICATIONS	CABLE ENTRANCE	PIN	SIGNAL	TECHNICAL SPECIFICATIONS
C1 (input)	14	NC	do not connect	C2 (output)	13	NC	do not connect
	16	TX-	Transmitter		15	TX-	Transmitter
	18	TX+	Transmitter		17	TX+	Transmitter
	20	RX-	Receiver		19	RX-	Receiver
	22	RX+	Receiver		21	RX+	Receiver

19.6 Remote pressure transducer connector - only for **SP, SL**

CABLE ENTRANCES	PIN	SIGNAL	TECHNICAL SPECIFICATIONS	NOTES	SP, SL - Single transducer (1)		SF - Double transducers (1)	
					Voltage	Current	Voltage	Current
D1	34	TR1	1st igital transducer ± 10 Vdc / ± 20 mA maximum range	Input - analog signal Software selectable	Connect	Connect	Connect	Connect
	35	AGND	Common gnd for transducer power and signals	Common gnd	Connect	/	Connect	/
	36	VF +24V	Power supply +24Vdc	Output - power supply	Connect	Connect	Connect	Connect

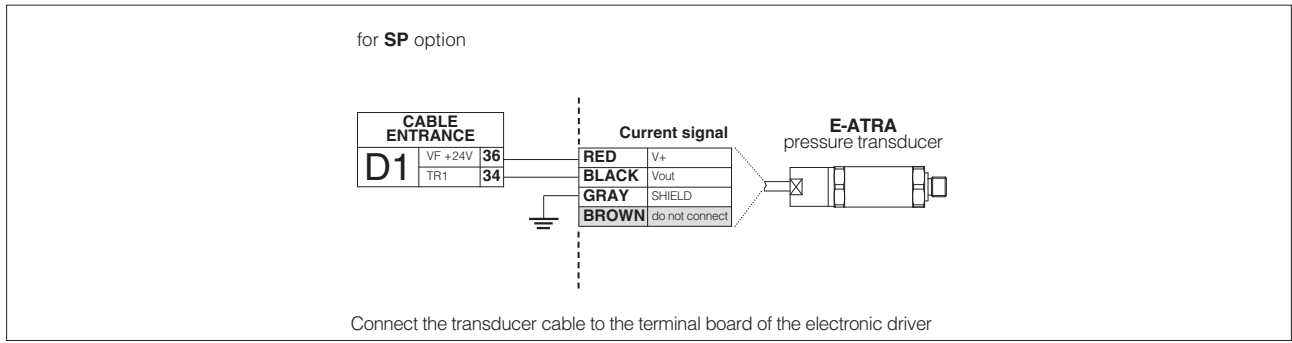

20 CONNECTIONS LAYOUT

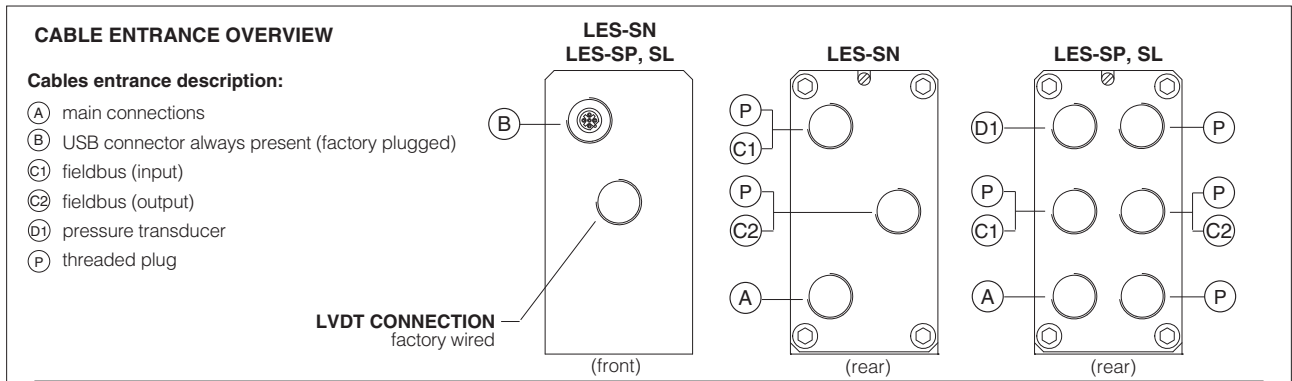

TERMINAL BOARD AND FIELDBUS TERMINATOR

Remove the 4 screws of driver's rear cover to access terminal board and fieldbus terminator

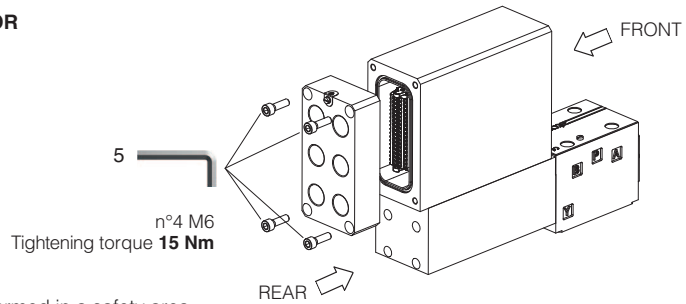

WARNING: the above operation must be performed in a safety area

Terminal board - see section 18

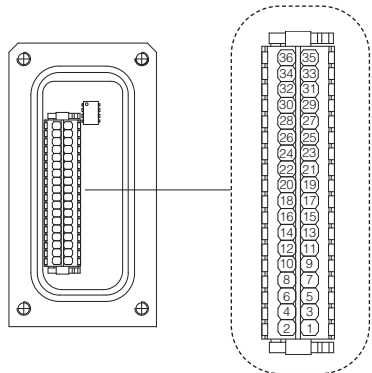

Fieldbus terminator only for BC and BP executions (1)

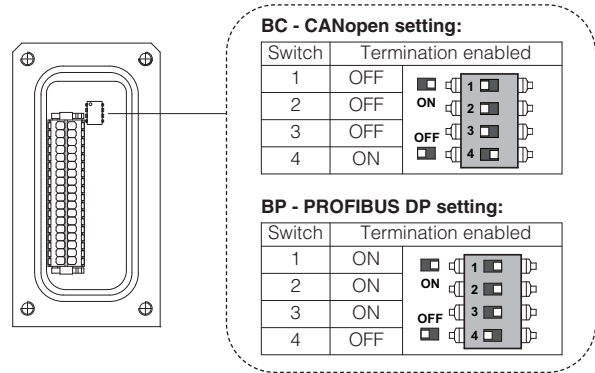

USB CONNECTOR

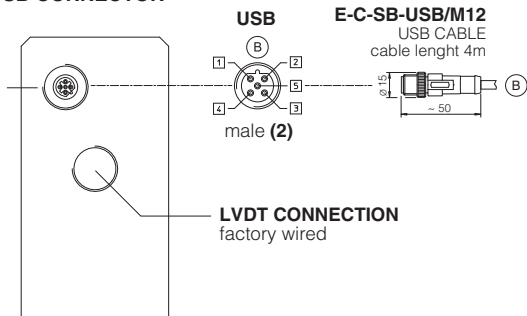

METALLIC PROTECTION CAP - supplied with the valves

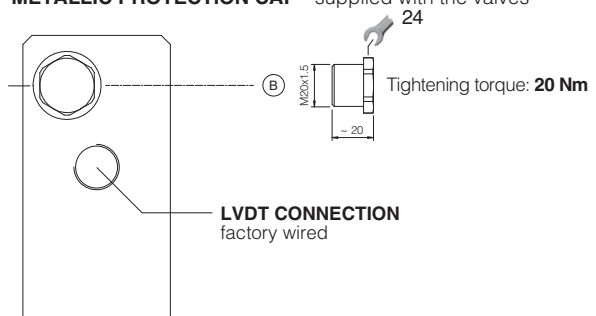

(1) Drivers with BC and BP fieldbus interface are delivered by default 'Not Terminated'. All switches are set OFF
(2) Pin layout always referred to driver's view

20.1 Cable glands and threaded plug for LES-SN - see tech table KX800

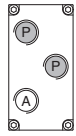
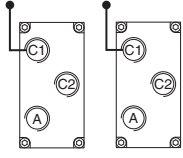
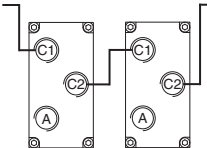
Communication interfaces	To be ordered separately				Cable entrance overview	Notes
	Cable gland quantity	entrance	Threaded plug quantity	entrance		
NP	1	A	none	none		Cable entrance A is open for costumers Cable entrance P are factory plugged
BC, BP, EH, EW, EI, EP "via stub" connection	2	C1 A	1	C2		Cable entrance A, C1, C2 are open for costumers
BC, BP, EH, EW, EI, EP "daisy chain" connection	3	C1 C2 A	none	none		Cable entrance A, C1, C2 are open for costumers

20.2 Cable glands and threaded plug for LES-SP, SL - see tech table KX800

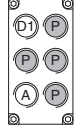
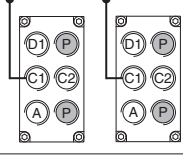
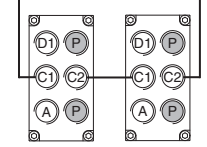
Communication interfaces	To be ordered separately				Cable entrance overview	Notes
	Cable gland quantity	entrance	Threaded plug quantity	entrance		
NP	2	D1 A	none	none		Cable entrance A, D1 are open for costumers Cable entrance P are factory plugged
BC, BP, EH, EW, EI, EP "via stub" connection	3	D1 C1 A	1	C2		Cable entrance A, C1, C2, D1 are open for costumers Cable entrance P are factory plugged
BC, BP, EH, EW, EI, EP "daisy chain" connection	4	D1 C1 - C2 A	none	none		Cable entrance A, C1, C2, D1 are open for costumers Cable entrance P are factory plugged

21 AIR BLEEDING

Size 25

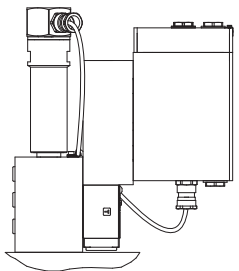

Sizes 32, 40

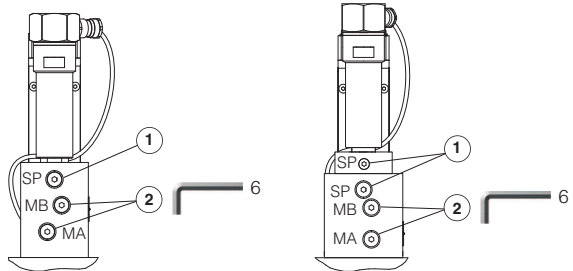

Sizes 50 to 80

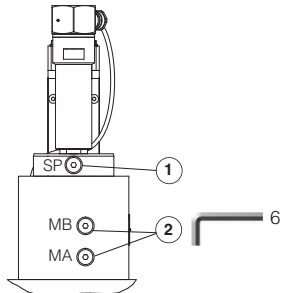

① **Plugged port - do not open**

② **Air bleeding (MA, MB):**
 N° 2 plugs G1/4"
 At the machine commissioning it is advisable to bleed the air from piloting chambers, by loosening the 2 plugs shown in the picture.
 Operate the valve for few seconds at low pressure and then lock the plugs.

22 INSTALLATION DIMENSIONS [mm]

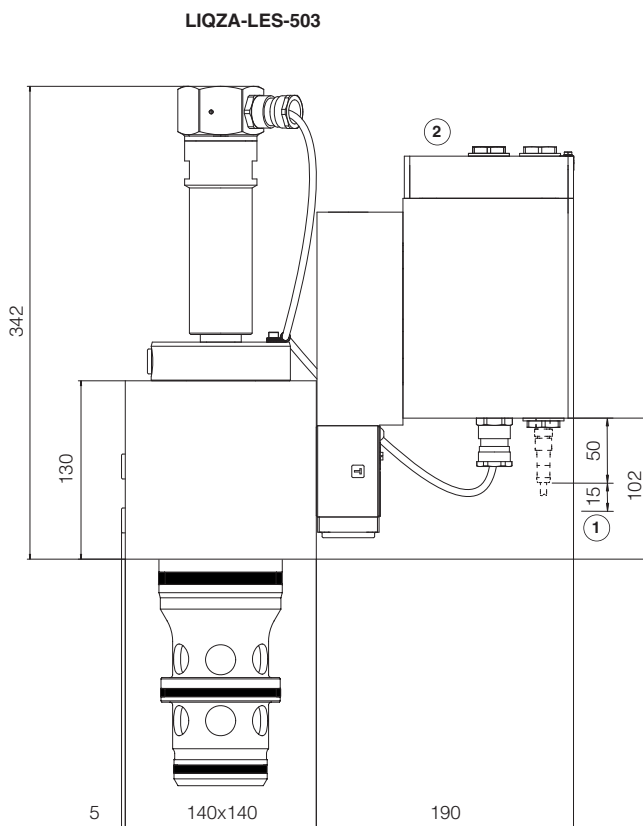
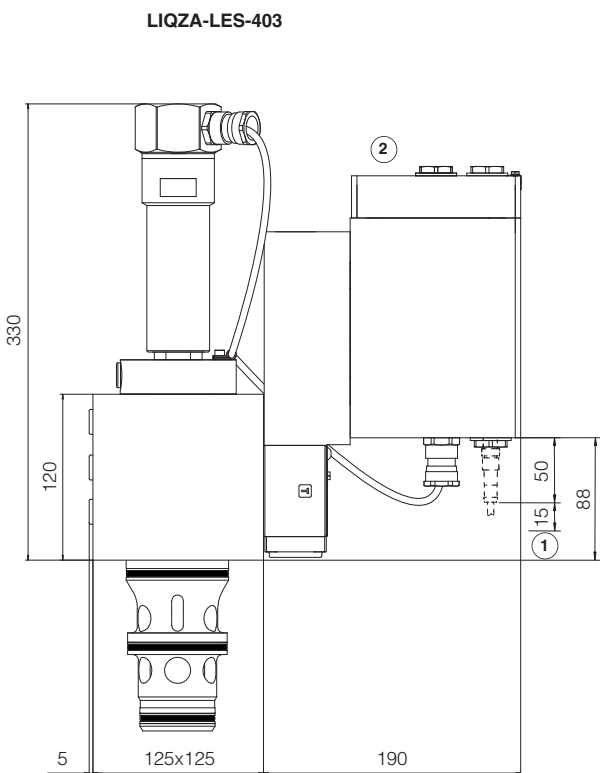
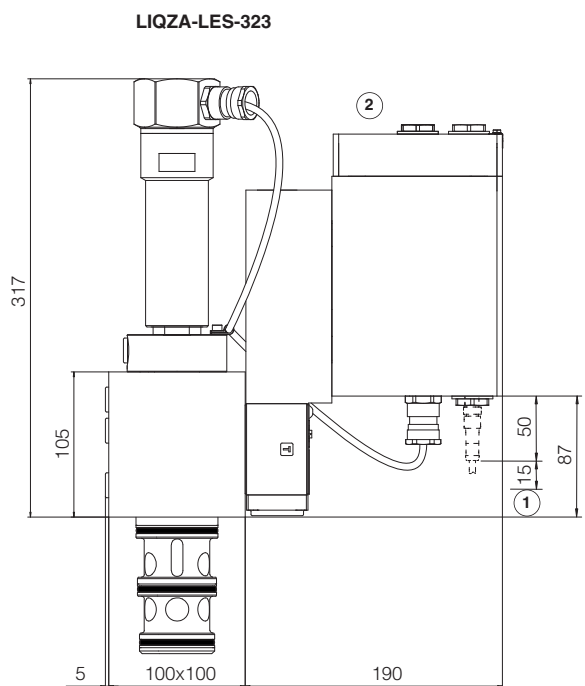
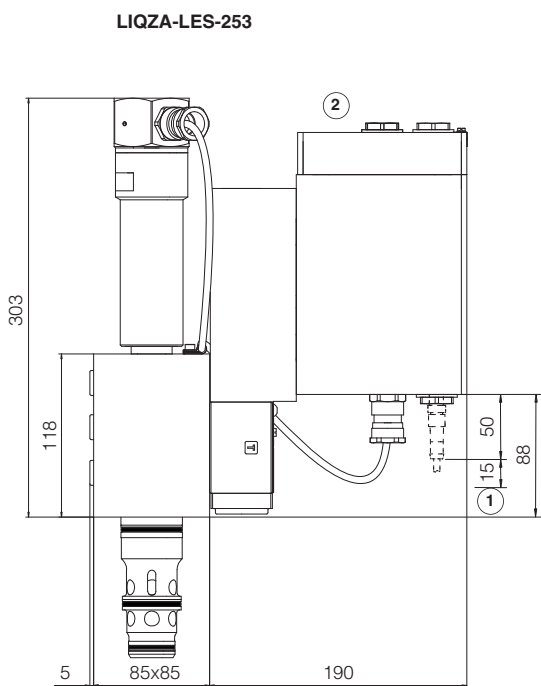

① = Space to remove the USB connector

② = The dimensions of all cable glands must be considered (see tech. table KX800)

Note: for mounting surface and cavity dimensions, see table P006

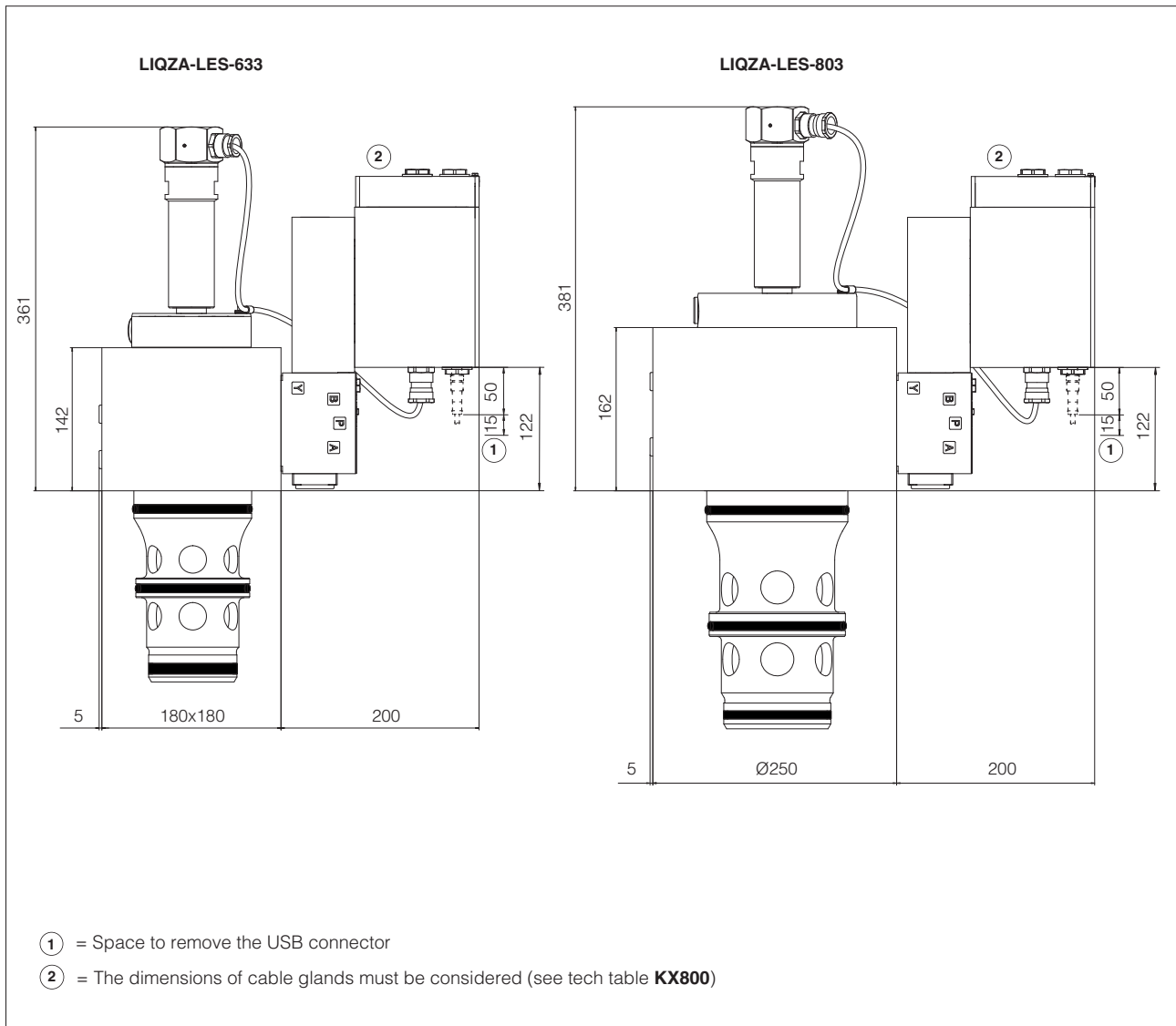

23 FASTENING BOLTS AND VALVE MASS

Type	Size	Fastening bolts (1) supplied with the valve	Mass [kg]
LIQZA	25	4 socket head screws M12x100 class 12.9 Tightening torque = 125 Nm	15,8
	32	4 socket head screws M16x60 class 12.9 Tightening torque = 300 Nm	18,2
	40	4 socket head screws M20x70 class 12.9 Tightening torque = 600 Nm	23,7
	50	4 socket head screws M20x80 class 12.9 Tightening torque = 600 Nm	31,6
	63	4 socket head screws M30x120 class 12.9 Tightening torque = 2100 Nm	51,6
	80	8 socket head screws M24x80 class 12.9 Tightening torque = 1000 Nm	79,2

24 RELATED DOCUMENTATION

X010	Basics for electrohydraulics in hazardous environments	GS500	Programming tools
X020	Summary of Atos ex-proof components certified to ATEX, IECEx, EAC, PESO	GS510	Fieldbus
FX500	Ex-proof digital proportionals with P/Q control	GX800	Ex-proof pressure transducer type E-ATRA-7
FX630	Ex-proof servoproportionals with on-board axis card	KX800	Cable glands for ex-proof valves
FX900	Operating and maintenance information for ex-proof proportional valves	P006	Mounting surfaces and cavities for cartridge valves