



# MERS

## FLOW RESTRICTOR VALVE

### SERIES 50

#### MODULAR VERSION ISO 4401-03

**p** max 350 bar  
**Q** max (see table of performances)

#### MOUNTING INTERFACE

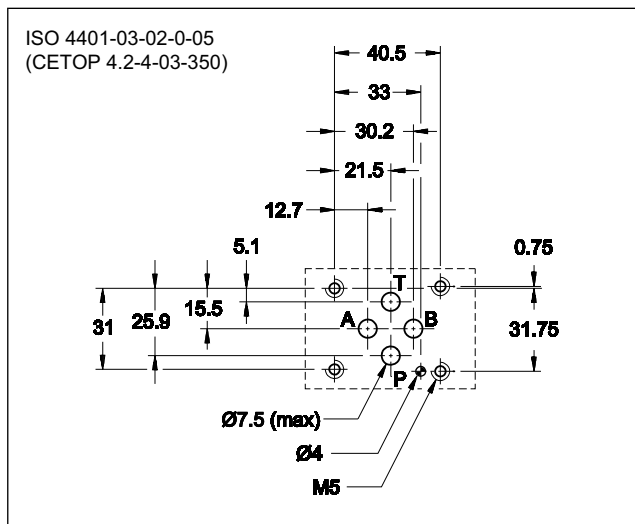

#### CONFIGURATIONS (see hydraulic symbols table)

- "D": independently controls the output flow from the two actuator chambers.
- "RD": independently controls the inlet flow in the two actuator chambers.
- "SA": controls the output flow from the actuator on line A.
- "SB": controls the output flow from the actuator on line B.
- "G\*": reversible valve. See par. 1.

#### PERFORMANCES (measured with mineral oil of viscosity 36 cSt at 50°C)

Maximum operating pressure	bar	350
Check valve cracking pressure		0,5
Maximum flow rate in the controlled lines	l/min	50
Maximum flow rate in the free lines		75
Min. controlled flowrate with $\Delta p$ 10 bar		$\leq 0,060$
Ambient temperature range	°C	-20 / +60
Fluid temperature range	°C	-20 / +80
Fluid viscosity range	cSt	10 ÷ 400
Fluid contamination degree	According to ISO 4406:1999 class 20/18/15	
Recommended viscosity	cSt	25
Mass	kg	1,3

#### OPERATING PRINCIPLE

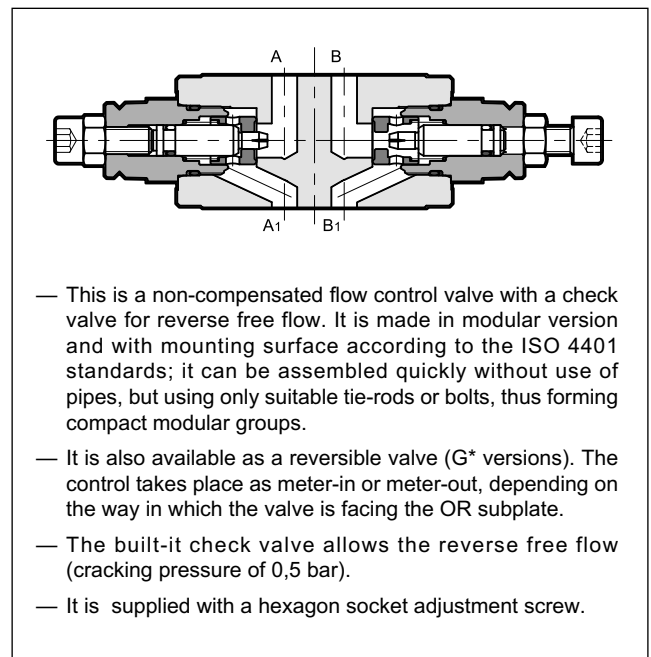

#### HYDRAULIC SYMBOLS

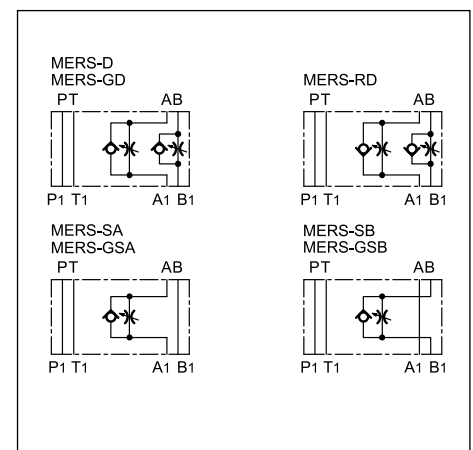

## 1 - IDENTIFICATION CODE

	<b>M</b>	<b>E</b>	<b>R</b>	<b>S</b>	<b>-</b>		<b>/</b>		<b>/</b>	<b>50</b>	<b>/</b>		
--	----------	----------	----------	----------	----------	--	----------	--	----------	-----------	----------	--	--

ISO 4401-03 size  
Modular version

Flow restrictor valve with check valve for reverse free flow

Configurations:  
**D:** meter-out control in lines A and B (**standard**)  
**RD:** meter-in control in lines A and B  
**SA:** meter-out control in line A  
**SB:** meter-out control in line B

Configurations G\* - reversible valve (**NOTE 1**)  
**GD:** control in lines A and B  
**GSA:** control in line A  
**GSB:** control in line A

Option: W7 surface treatment. Omit if not required (**NOTE 2**)

Seals:  
omit for mineral oils  
**V** = viton for special fluids

Series No.  
(the overall and mounting dimensions remain unchanged from 50 to 59)

**M** = Adjustment with SICBLOC knob  
(omit for adjustment with hexagonal head adjustment screw)

**NOTE 1:** the valve body does not provide the OR seats. The mounting interface is achieved by interposition of an OR subplate. The control of flow (meter-in or meter-out) is depending on the way of assembly the valve on the subplate.

**NOTE 2:** Upon request we can supply these valves completely with zinc-nickel surface treatment on the body. Add the suffix **/W7** at the end of the identification code.

## 2 - CHARACTERISTIC CURVES

(values obtained with viscosity of 36 cSt at 50°C)

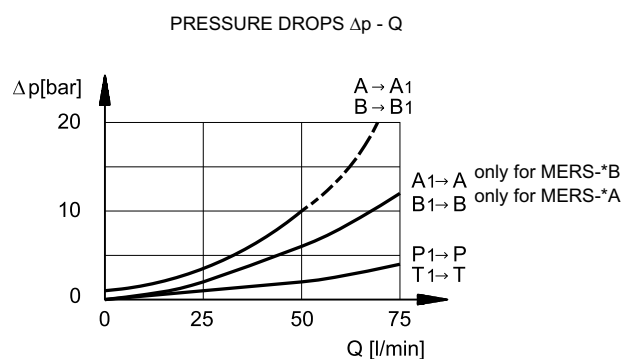
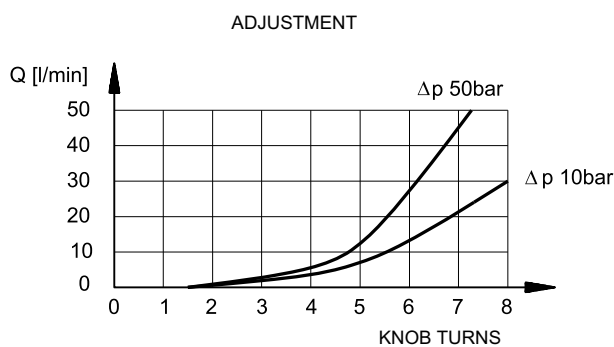

## 3 - HYDRAULIC FLUIDS

Use mineral oil-based hydraulic fluids HL or HM type, according to ISO 6743-4. For these fluids, use NBR seals. For fluids HFDR type (phosphate esters) use FPM seals (code V). For the use of other kinds of fluid such as HFA, HFB, HFC, please consult our technical department.

Using fluids at temperatures higher than 80 °C causes a faster degradation of the fluid and of the seals characteristics. The fluid must be preserved in its physical and chemical characteristics.

## 4 - MERS -D, -RD and -S\* - OVERALL AND MOUNTING DIMENSIONS

dimensions in mm

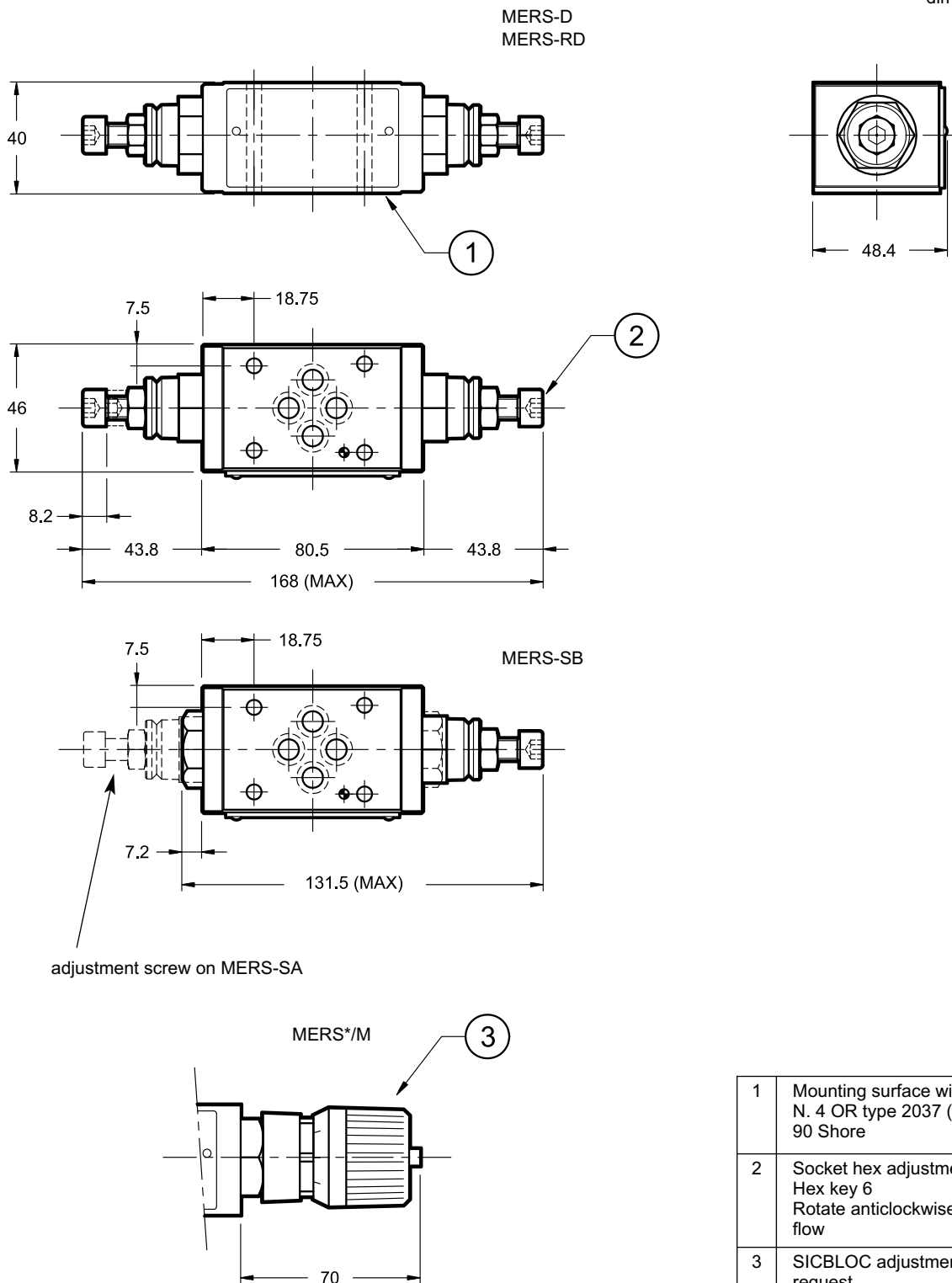

1	Mounting surface with sealing rings: N. 4 OR type 2037 (9.25x1.78) 90 Shore
2	Socket hex adjustment screw: Hex key 6 Rotate anticlockwise to increase flow
3	SICBLOC adjustment knob, upon request. To operate, push and rotate at the same time.

## 4 - MERS-G\* - OVERALL AND MOUNTING DIMENSIONS

