



# PRK10

## PILOT OPERATED PRESSURE CONTROL VALVE SERIES 12

**CARTRIDGE TYPE**  
seat 7/8-14 UNF-2B (SAE - 10)

**p** max 350 bar  
**Q** max 120 l/min

### SEAT DIMENSIONS: 7/8 - 14 UNF-2B (SAE - 10)

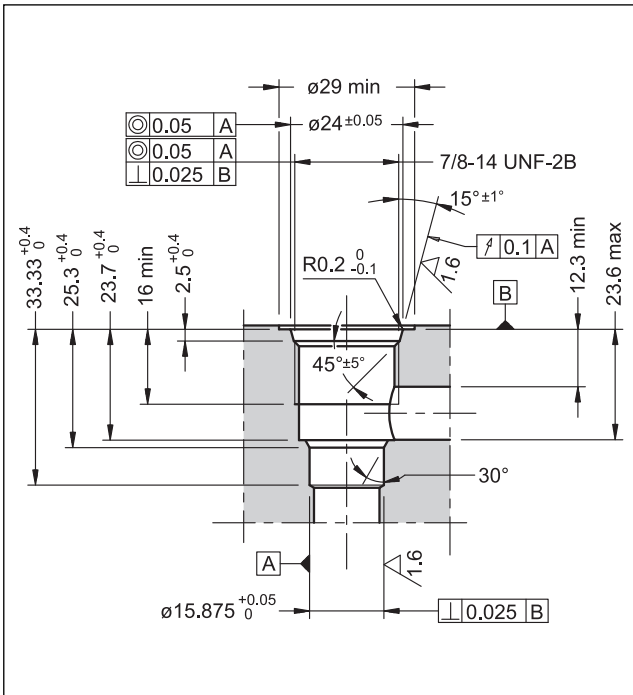

### OPERATING PRINCIPLE

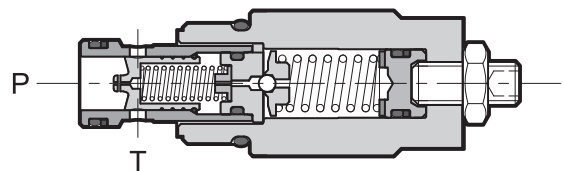

- The PRK10 valve is a pilot operated pressure control valve, cartridge type, that can be used in blocks or panels with 7/8-14 UNF-2B (SAE - 10) type seat.
- It is used to control the hydraulic circuit pressure and allows use of the entire flow of the pump even at pressure values near the set value.
- It consists of a main balanced type spool and a pilot stage. The main spool, normally closed, opens when the circuit pressure exceeds the set value generated by the pilot stage, discharging the excess flow in port T, directly connected to the tank.
- It's available in 4 pressure control ranges from 6 to 350 bar.
- The PRK10 are supplied with a finishing surface treatment (zinc-nickel) suitable to ensure a salt spray resistance up to 600 h (test according to UNI EN ISO 9227 standards and test evaluation according to UNI EN ISO 10289 standards)
- The pressure is adjustable by a socket set screw with locking nut, or by knob.

### PERFORMANCES

(measured with mineral oil of viscosity 36 cSt at 50°C)

Max working pressure	bar	350
Minimum controlled pressure and pressure drop	see diagram	
Maximum flow rate	l/min	120
Ambient temperature range	°C	-20 / +60
Fluid temperature range	°C	-20 / +80
Fluid viscosity range	cSt	10 + 400
Fluid contamination degree	According to ISO 4406:1999 class 20/18/15	
Recommended viscosity	cSt	25
Mass	kg	0,2
Surface finishing: galvanic treatment	zinc-nickel	

### HYDRAULIC SYMBOL

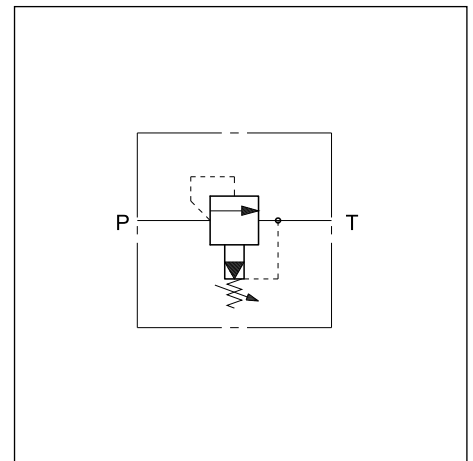

### 1 - IDENTIFICATION CODE

<b>P</b>	<b>R</b>	<b>K</b>	<b>10</b>	<b>-</b>	<b>/</b>	<b>12</b>	<b>/</b>	
----------	----------	----------	-----------	----------	----------	-----------	----------	--

Pressure control valve, pilot operated

Cartridge type \_\_\_\_\_

Size \_\_\_\_\_

Pressure adjustment range: \_\_\_\_\_

**070** = from 14 to 70 bar (17 bar/turn)      **210** = from 14 to 210 bar (47 bar/turn)  
**140** = from 14 to 140 bar (32 bar/turn)      **350** = from 14 to 350 bar (78 bar/turn)

Option: **K** = Adjustment knob.  
Omit for adjustment with hex socket screw (**standard**)

Seals:  
**N** = NBR seals for mineral oils (**standard**)  
**V** = FPM seals for special fluids

Series No.  
(the overall and mounting dimensions remain unchanged from 10 to 19)

**⚠ NOTE:** the maximum regulated pressure value is reached when the screw is flush with the nut.  
**Screwing over this limit can damage the valve.**

### 2 - CHARACTERISTIC CURVES

(values obtained with viscosity of 36 cSt at 50°C)

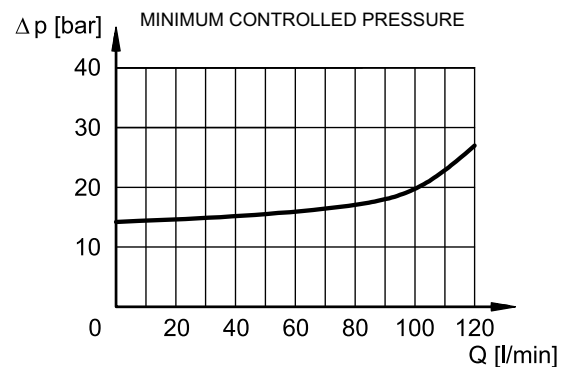
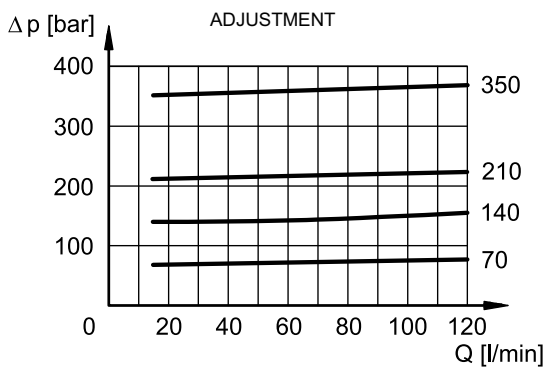

### 3 - HYDRAULIC FLUIDS

Use mineral oil-based hydraulic fluids HL or HM type, according to ISO 6743-4. For these fluids, use NBR seals (code N). For fluids HFDR type (phosphate esters) use FPM seals (code V). For the use of other kinds of fluid such as HFA, HFB, HFC, please consult our technical department. Using fluids at temperatures higher than 80 °C causes a faster degradation of the fluid and of the seals characteristics.

The fluid must be preserved in its physical and chemical characteristics.

### 4 - OVERALL AND MOUNTING DIMENSIONS

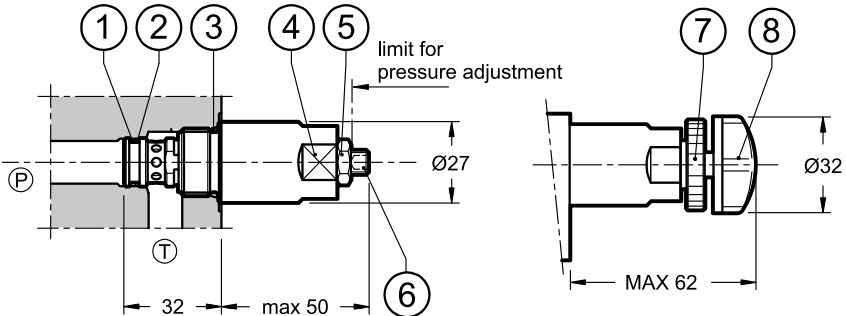

dimensions in mm	
1	OR type 2050 (12.42x1.78)
2	Parbak 8-014 (13.23x1.14x1.35)
3	OR type 3-910 (19.18x2.46)
4	Cartridge tightening: spanner 24 Tightening torque 38 Nm
5	Locking nut: spanner 13
6	Socket hex adjustment screw: Hex key 4. Rotate clockwise to increase pressure
7	Locking ring
8	Adjustment knob: K