

RPC*

PRESSURE AND TEMPERATURE COMPENSATED FLOW CONTROL VALVES



SUBPLATE MOUNTING

RPC2 ISO 6263-06
RPC3 ISO 6263-07

HYDRAULIC SYMBOL

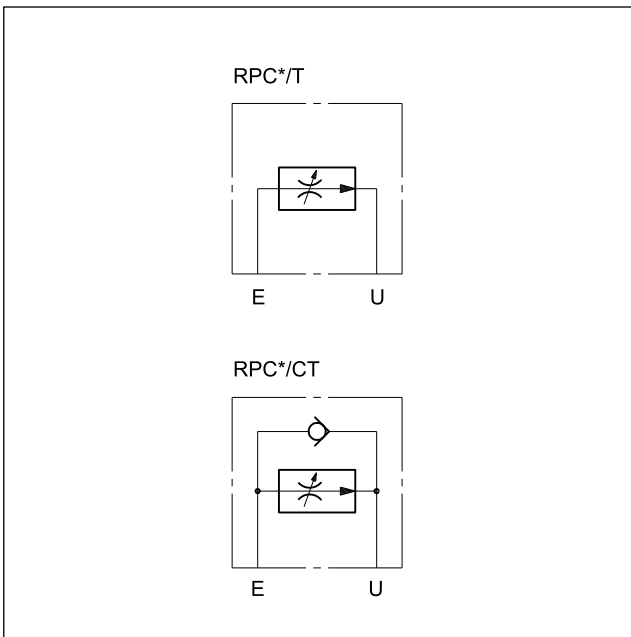

OPERATING PRINCIPLE

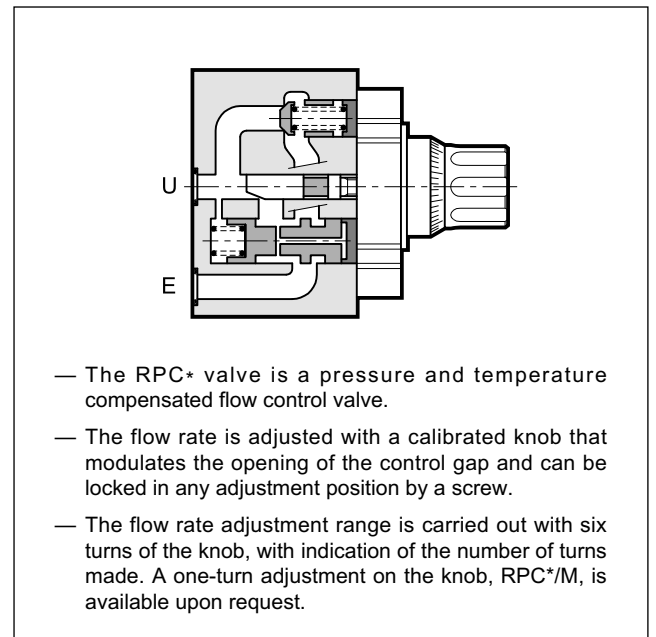

PERFORMANCES

(obtained with mineral oil with viscosity of 36 cSt at 50°C)

		RPC2	RPC3
Maximum operating pressure		320	250
Check valve cracking pressure	bar	0,5	0,5
Minimum pressure difference between E and U		10	12
Maximum controlled flow rates		22 - 38 - 70	100 - 150
Minimum controlled flow rate	l/min	0,050	0,120
Ambient temperature range	°C	-20 / +60	
Fluid temperature range	°C	-20 / +80	
Fluid viscosity range	cSt	10 + 400	
Fluid contamination degree		According to ISO 4406:1999 class 20/18/15	
Recommended viscosity	cSt	25	
Mass	kg	3,6	7,8

1 - IDENTIFICATION CODE

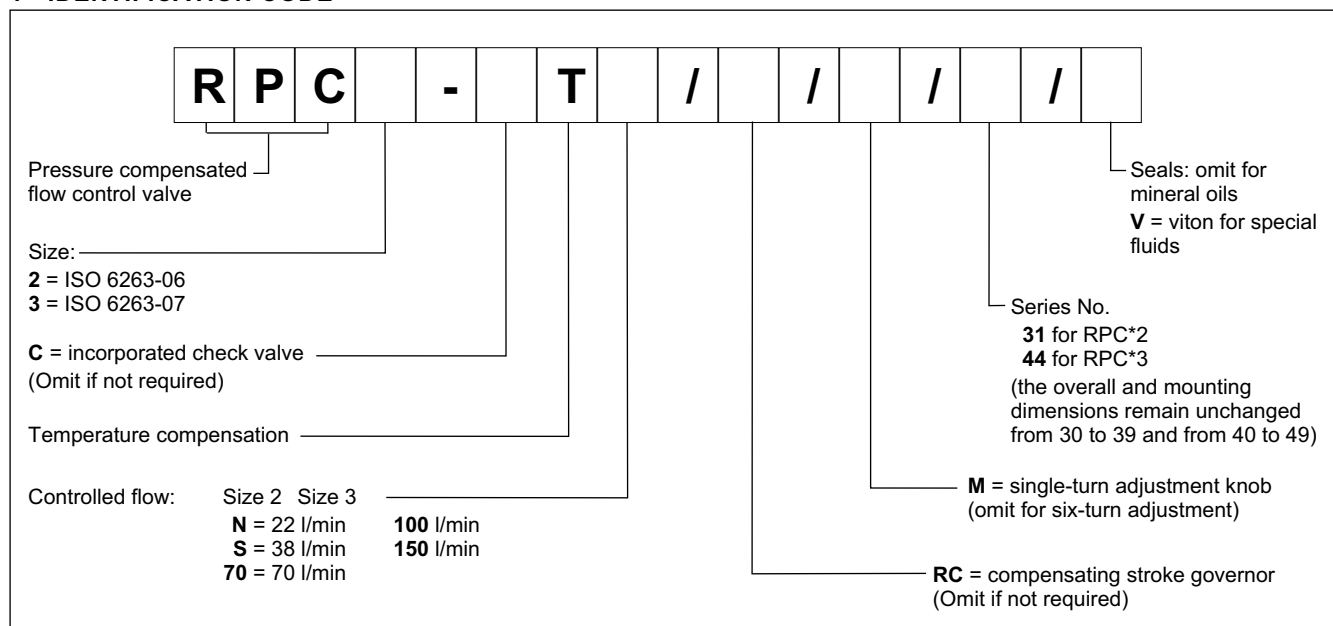

2 - CHARACTERISTIC CURVES

(values obtained with viscosity of 36 cSt at 50°C)

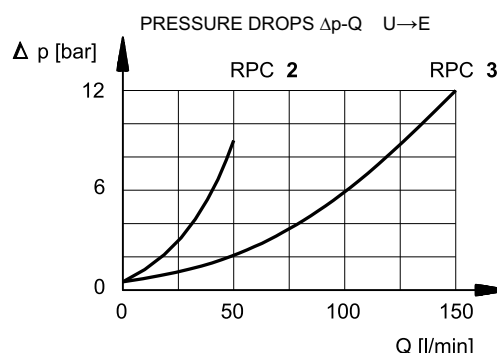
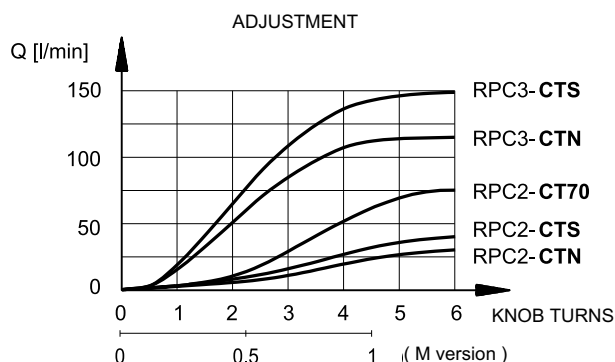

3 - HYDRAULIC FLUIDS

Use mineral oil-based hydraulic fluids HL or HM type, according to ISO 6743-4. For these fluids, use NBR seals. For fluids HFDR type (phosphate esters) use FPM seals (code V).

For the use of other kinds of fluid such as HFA, HFB, HFC, please consult our technical department. Using fluids at temperatures higher than 80 °C causes a faster degradation of the fluid and of the seals characteristics.

The fluid must be preserved in its physical and chemical characteristics.

4 - PRESSURE COMPENSATION

Two throttles in series are in the valve. The first is an opening regulated by the knob; the second, piloted by the pressure upstream and downstream of the first throttle, assures a constant pressure drop across the adjustable throttle.

In these conditions, the set flow rate value stays constant within a tolerance range of $\pm 3\%$ of the maximum flow controlled by the valve for the maximum pressure variation between inlet and outlet chambers of the valve.

5 - TEMPERATURE COMPENSATION

A device located on the first throttle which is sensitive to the temperature fluctuations corrects the position keeping the controlled flow more or less unaltered even should the oil viscosity change.

The fluctuation of the set flow rate stays within $\pm 2,5\%$ of the maximum flow controlled by the valve.

6 - REVERSE FREE FLOW

The RPC* valves, upon request, are supplied with an incorporated check valve to allow free flow in the direction opposite of the controlled flow. In this case the valve code becomes RPC*-CT.

7 - COMPENSATING STROKE GOVERNOR

In order to avoid jumps in the actuator when it is started, the RPC valve can be equipped with a special accessory that controls the compensating stroke, thus preventing it from making uncontrolled movements.

Add the suffix **RC** to the identification code to request this governor. See paragraph 1.

8 - RPC2 OVERALL AND MOUNTING DIMENSIONS

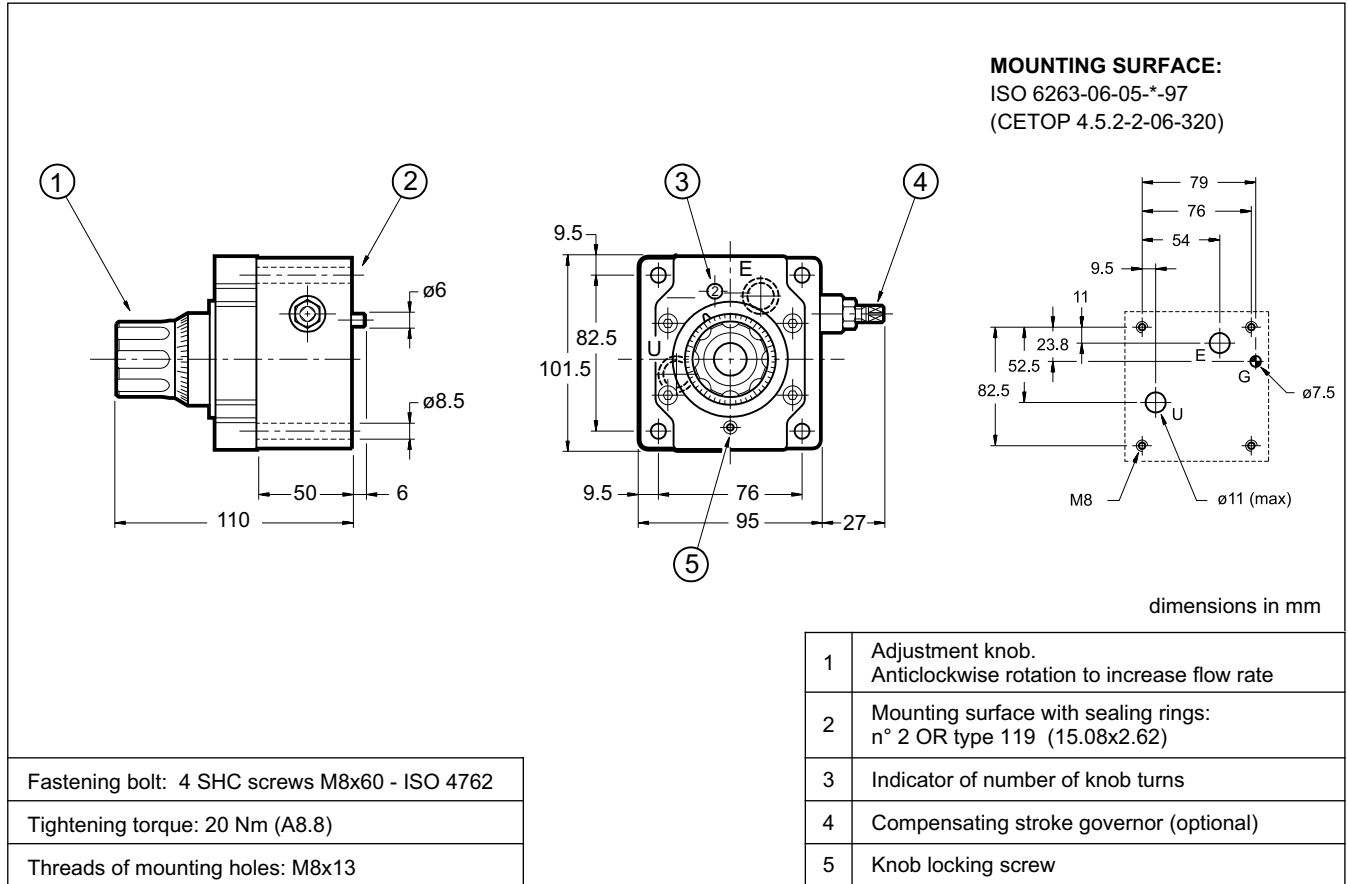

9 - RPC3 OVERALL AND MOUNTING DIMENSIONS

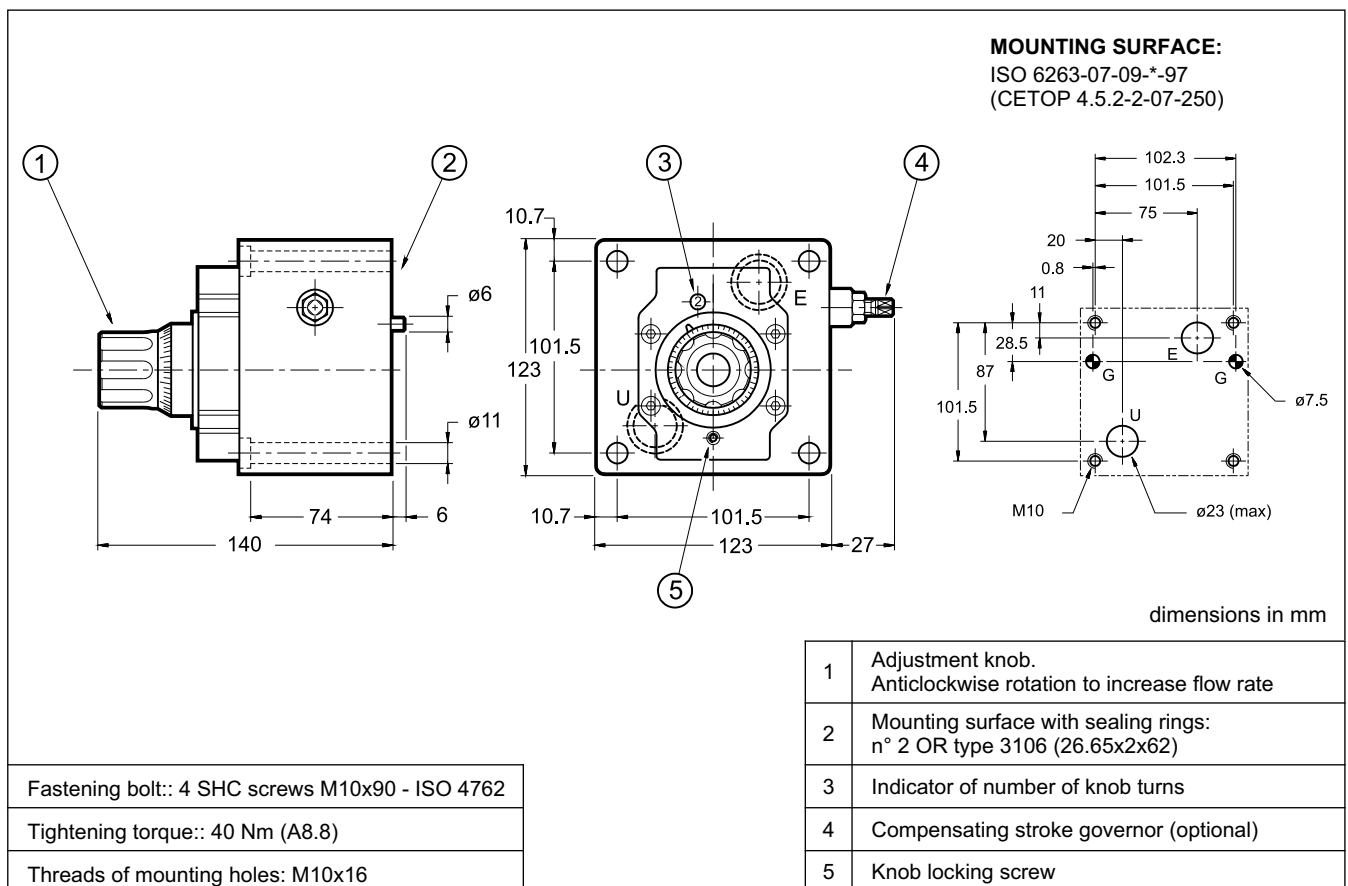



RPC*

10 - SUBPLATES

(see catalogue 51 000)

	RPC2	RPC3
Type	PMRPC2-AI4G rear ports	PMRPC3-AI6G rear ports
Port dimensions	1/2" BSP	1" BSP