

UEIK-2*RL

ELECTRONIC CONTROL UNIT FOR OPEN LOOP DOUBLE SOLENOID PROPORTIONAL VALVE

SERIES 51
WITH REFERENCE SIGNAL AND RAMP SELECTION

EUROCARD TYPE

FUNCTIONAL BLOCK DIAGRAM

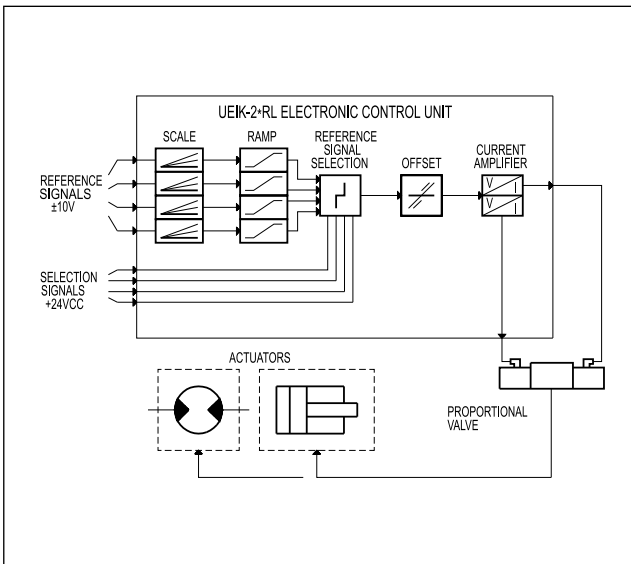

TECHNICAL CHARACTERISTICS

Power supply	V DC	22 ± 30 Ripple included
Required power	see paragraph 2.1	
Output current	vedi paragraph 3.4	
Power supply electrical protection	– overload – polarity inversion	
No. of selectable channels	4	
Reference signal	V	± 10 adjustable for each channel
Electromagnetic compatibility (EMC) (see par. 5 - NOTE 1)	in compliance with 2014/30/EU	
Card size	Eurocard 100x160x50	
Connector interface	DIN 41612-D 32 Male	
Operating temperature range	°C	0 ± 50
Mass	kg	0,3

FRONT PANEL

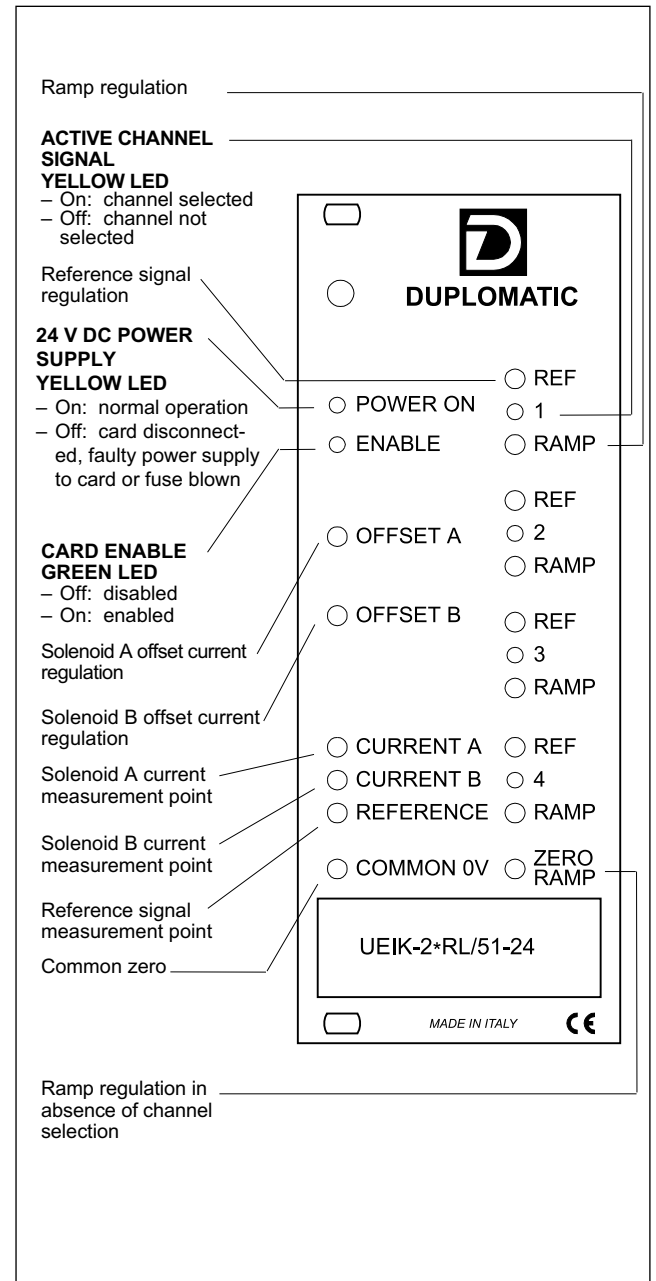

1 - IDENTIFICATION CODE

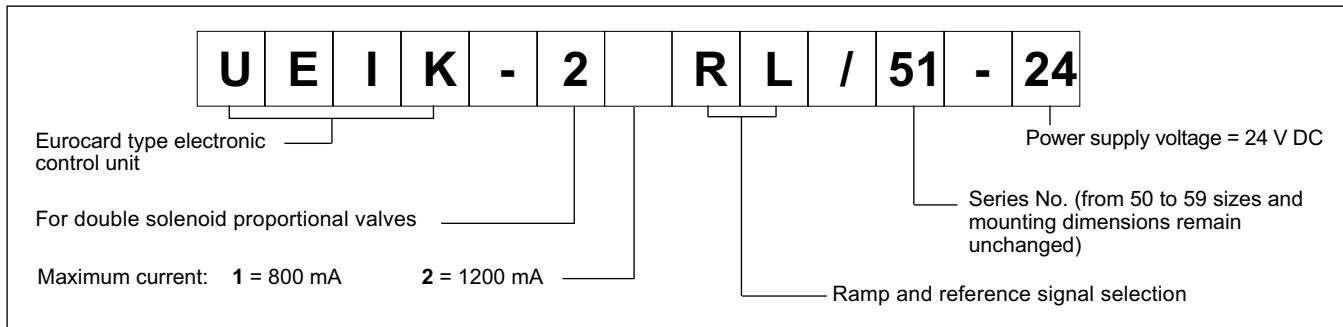

The UEIK-2*RL card is an electronic control unit in Eurocard format for open loop control of double solenoid proportional valves, with selection in sequence of four different reference and ramp time regulation signals.

The unit is suitable for management of "fast-slow" work cycles.

The front panel is fitted with LEDs to indicate card functions and potentiometers to optimise performance.

2 - FUNCTIONAL SPECIFICATIONS

2.1 - Electric power supply

The card requires a power supply of between 22 and 30 V DC (pin 2a/2c - 4a/4c) and 20 W (UEIK21-RL) - 29 W (UEIK-22-RL).

Power supply voltage must be rectified and filtered, with maximum admissible ripple within the above voltage range.

2.2 - Electrical protection

The card is protected against overvoltage and polarity inversion.

A 2A fast-acting fuse is fitted for power circuit protection.

3 - SIGNALS AND ADJUSTMENT

3.1 - POWER ON

The yellow LED indicates card power supply:

ON - normal power supply

OFF - no power supply, faulty power supply or blown fuse

3.2 - ENABLE

A 22 to 30 V DC on pin 24c enable command is required for card operation.

The condition of the enable card is shown by both a visible LED on the front panel and as a contact available for the user on pins 6a and 6c.

The green LED indicates:

ON - card enabled

OFF - card disabled or failed

3.3 - OFFSET A / OFFSET B (Polarization current regulation of solenoids A and B)

"OFFSET A" and "OFFSET B" potentiometers enable regulation of the polarization current of the solenoids A and B respectively. They are used to eliminate the valve insensitivity zone (dead zone) in the two valve hydraulic configurations.

The regulation field is up between 0 and 0,5 A (UEIK-21-RL) and between 0 and 0,65 A (UEIK-22-RL). The default value is zero.

The offset current is activated when the reference signal exceeds the threshold of ± 150 mV.

The offset is not active and only the polarization current equal to 25 mA is present beneath this threshold.

NOTE: The variation of the set value of the offset current causes a corresponding variation of the scale factor value.

Rotate clockwise to increase current.

3.4 - REF (Reference signal regulation)

The card enables settings by means of multi-turn potentiometers on the front panel (indicated by "REF") of four different reference signal values (one per channel).

Solenoid A is controlled with positive reference of $0 + 10V$, and solenoid B is controlled with negative reference signal of $0 + -10V$.

Maximum output current, corresponding to the maximum potentiometers regulation, is limited to 1 A. See par. 6 for default settings.

Rotate clockwise to increase the reference signal by absolute values. See par. 9 for electrical connections.

One of the four channels can be selected automatically by transmitting a +24 V DC command to pin 18c (channel 1) - 18a (channel 2) - 20c (channel 3) - 20a (channel 4).

To obtain correct signal switching and continuous regulation with the selection of channels from 1 to 4, select the new channel before deactivating the previous one. A yellow LED illuminates on the front panel in correspondence to the channel selected.

NOTE: The system manages reference signals and ramp values of the channel with the highest selected number. To enable channel selection in reverse order (4 to 1) all previous channels must be deactivated.



3.5 - RAMP (Ramp regulation)

A "RAMP" potentiometer is associated with each of the channels to enable regulation of the time required to reach the current supplied according to the selected reference signal.

The regulation range is from 0,03 to 7 sec.

This makes it possible to smooth valve response and adapt it to the requirements of the hydraulic system and the machine cycle.

The "ZERO RAMP" potentiometer enables regulation of the valve deactivation time (current=0) when all channels are switched off.

Rotate clockwise to increase ramp time.

Ramps can be inhibited by transmitting a 22 to 30 V DC exclusion command to pin 16a. In this case, the ramp residual time is 10 ms.

4 - SIGNAL MEASUREMENT

4.1 - CURRENT A / CURRENT B

(Current measurement points of solenoids A and B)

Measurement points for voltage readings of current supplied to solenoids A and B.

Reading conversion is 1V DC = 1A (UEIK-21-RL) and

0,82 V DC = 1A (UEIK-22-RL).

4.2 - REFERENCE (Reference signal measurement point)

Enables reading of reference signal related to the selected channel, in voltage, but of the opposite sign.

5 - INSTALLATION

The card is suitable for assembly on a rack or a card holder with interface for connector types DIN 41612 - size D - 32 pole.

It is recommended to use cable sections of 1 to 2,5 mm², in function with their length, for power supply and solenoid connections. For other connections, it is advisable to use cables with a screened sheath connected to earth only on the card side.

NOTE 1

To observe EMC requirements it is important that the control unit electrical connection is in strict compliance with the wiring diagram of par. 9.

As a general rule, the valve and the electronic unit connection wires must be kept as far as possible from interference sources (e.g. power wires, electric motors, inverters and electrical switches).

In environments that are critical from the electromagnetic interference point of view, a complete protection of the connection wires can be requested.

6 - DEFAULT CONDITIONS

The electronic control unit is supplied factory-set.

Standard settings are:

- "OFFSET" regulation: zero
- "REF" regulation: corresponding to 0,82A to A and B solenoids
- "RAMP" regulation: minimum
- position SW1 on V
- position SW2 on S
- position SW3 on AA
- switching frequency (PWM) = 200Hz (UEIK-21-RL) - 100Hz (UEIK-22-RL)

7 - START-UP AND FRONTAL SETTINGS

Settings can be modified and references can be regulated according to specific work cycles as follows:

a) OFFSET CURRENT REGULATION

- Select one of the channels connected to positive reference +10V (pin 10a).
- Regulate the relative potentiometer "REF" at a value between 200 and 300 mV (for reference signal see par. 4.2)
- Regulate the "OFFSET A" potentiometer so that the valve is positioned at the start of the work zone controlled by solenoid "A".

Repeat the procedure by selecting a channel connected to the negative reference -10V (pin 10c) and regulate the "OFFSET B" potentiometer.

b) REFERENCE REGULATION

- Select a channel and regulate the relative "REF" potentiometer to obtain the required actuator speed.
- Repeat the procedure for all four channels to obtain the required speed cycle.

c) RAMP REGULATION

- Regulate the four "RAMP" potentiometers to obtain the required regulation smoothness during passage from one channel to another.
- Regulate the "ZERO RAMP" potentiometer to obtain regulation smoothness when all four channels are deactivated.

8 - CARD CIRCUIT SETTINGS

The overall dimension diagram in par. 10 shows three switch banks: SW 1 - SW 2 - SW 3 which enable card set up as required.

NOTE: Each modification to switch settings must be carried out with the card disconnected from the power supply. The individual switches inside each bank must all be set in the same position.

SELECTION OF SINGLE ENDED OR DIFFERENTIAL REFERENCE SIGNAL (SW 2 bank comprising one individual switch)

- select S for single ended. This condition is obligatory in the case that the reference signal is generated with the four potentiometers inside the card.
- by selecting D (differential), it is possible to add an external reference signal that can control the valve during the manual cycle.

- **SW 1 bank (comprising three individual switches) must always be set on V, as per standard supply conditions.**
- **SW 3 bank (comprising two individual switches) must always be set on AA, as per standard supply conditions.**

SWITCHING FREQUENCY ADJUSTMENT

It is possible to change the switching frequency (PWM) by acting on the trimmer PT7 (see par. 10).

The setting range is from 80 to 370 Hz.

An appropriate switching frequency adjustment allows reduction of the valve hysteresis value.

Clockwise rotation to increase the frequency.



UEIK-2*RL

SERIES 52

9 - CARD CIRCUIT AND WIRING DIAGRAM

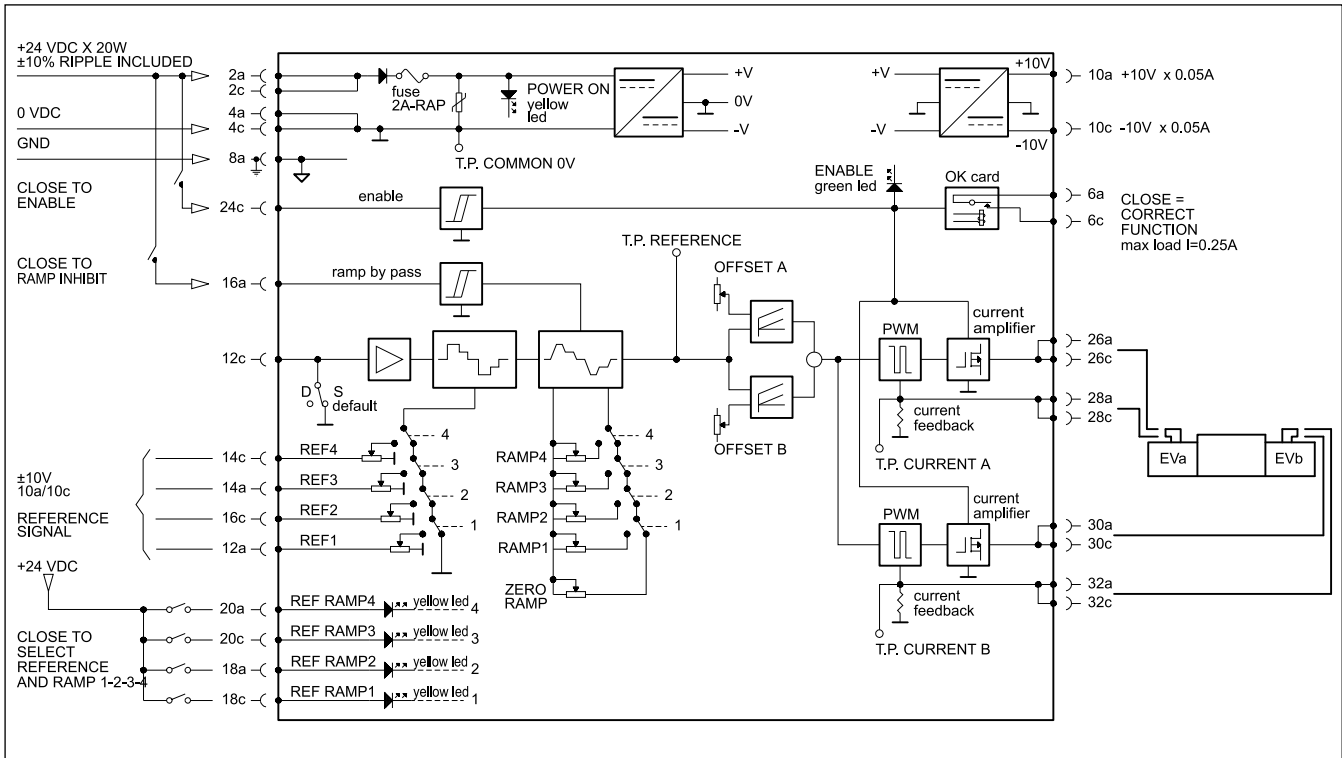

10 - OVERALL AND MOUNTING DIMENSIONS

