

Digital Z-BM-TEZ/LEZ axis cards with driver functionality

DIN-rail format, for position and force controls

Z-BM-TEZ- NP Not Present

Z-BM-TEZ- BC CANopen
BP PROFIBUS DP

Z-BM-TEZ- EH EtherCAT
EW POWERLINK
EI EtherNet/IP
EP PROFINET RT/IRT

Position Control 	Alternated Control P/Q	Internal Reference 	 DVD Z-SW-FULL Programming Software Z-SW-FULL programming software
Real-time Fieldbus Reference 	Enhanced Diagnostic 	USB port 	

Connectors ② included

Z-BM-TEZ/LEZ

Digital axis cards ① perform the driver functions for proportional valves plus the position closed loop control of the linear or rotative actuator to which the proportional valve is connected.

Z-BM-TEZ execution controls direct and pilot operated directional valves with one LVDT transducer.

Z-BM-LEZ execution controls directional pilot operated valves with two LVDT transducers. The controlled actuator has to be equipped with transducer (analog, SSI or Encoder) to read the axis position feedback.

The axis card can be operated via an external reference signal or automatic cycle, see section ④.

A force alternated control may be set by software additionally to the position control: a pressure/force transducer has to be assembled into the actuator and connected to the axis card; a second pressure/force reference signal is required.

Atos PC software allows to customize the axis card configuration to the specific application requirements.

Electrical Features:

- up to 11 fast plug-in connectors ②
- Mini USB port ③ always present
- DB9 fieldbus communication connector ④ for CANopen and ⑤ PROFIBUS DP
- RJ45 ethernet communication connectors ⑥ output and ⑦ input for EtherCAT, POWERLINK, EtherNet/IP, PROFINET
- 8 leds for diagnostics ⑧ (see 8.1)
- Electrical protection against reverse polarity of power supply
- Operating temperature range: $-20 \div +50$ °C
- Plastic box with IP20 protection degree and standard DIN-rail mounting
- CE mark according to EMC directive

Software Features:

- Intuitive graphic interface
- Internal generation of motion cycle
- Setting of axis dynamic response (PID) to optimize the application performances
- Setting of valve's functional parameters: bias, scale, ramps, dither
- Linearization function for hydraulic regulation
- Complete diagnostics of axis status
- Internal oscilloscope function
- In field firmware update through USB port

1 MODEL CODE

Z-BM	-	TEZ	-	NP	-	01H	/	*	/	*
Off-board electronic axis card in DIN rail format										Set code (see section ⑨)
TEZ = digital full driver + axis card, for valves with one LVDT transducer LEZ = digital full driver + axis card, for valves with two LVDT transducers										Series number
Fieldbus interface , USB port always present: NP = Not Present BC = CANopen BP = PROFIBUS DP EH = EtherCAT EW = POWERLINK EI = EtherNet/IP EP = PROFINET RT/IRT										Options , see section ③ : A = max current limitation for Ex-proof valves C = current feedback $4 \div 20$ mA for LVDT transducers, only in combination with option A
										01H = for single solenoid proportional valves 05H = for double solenoid proportional valves (only for TEZ)

2 BLOCK DIAGRAM EXAMPLE

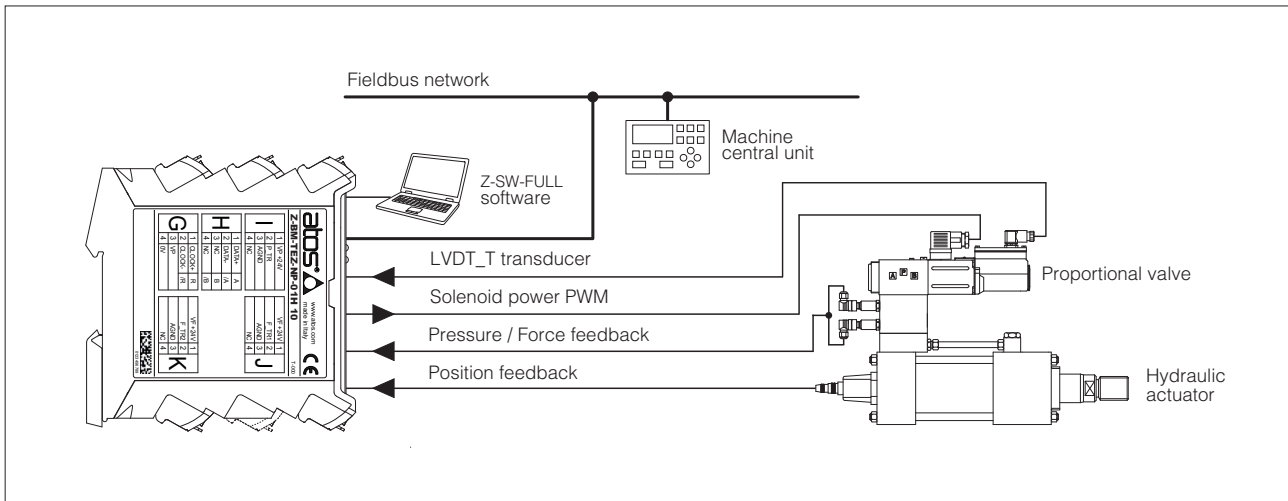

Note: block diagram example for alternated position/force control, with fieldbus interface

3 VALVES RANGE

Valves	Directional		
Industrial Tech table	DHZO-T, DKZOR-T F168	DLHZO-T, DLKZOR-T F180	DPZO-L F178
Ex-proof Tech table	-	DLHZA-T, DLKZA-T FX140	-
Axis card model	Z-BM-TEZ		Z-BM-LEZ

4 POSITION CONTROL

4.1 External reference signal

Axis card controls in closed loop the actuator position according to a reference signal from the machine central unit.

Position profile can be managed in two ways (software selectable):

- Without trajectory generation **(a)**: the axis card receives from the machine central unit the reference signal and follows it at any given instant
- With trajectory generation **(b)**: the axis card receives from the machine central unit just the final target position and internally generates a position profile limiting acceleration, velocity and deceleration

The reference signal can be software selected between Analog **(c)** and Fieldbus reference **(d)**.

Refer to the axis card user manual for further details on position control features.

External reference signal

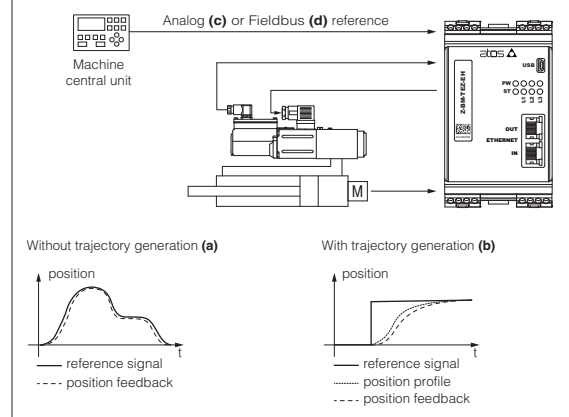

4.2 Automatic cycle

Axis card controls in closed loop the actuator position according to an internally generated automatic cycle: only start, stop and switch-over commands are required from the machine electronic central unit by means On-off commands **(e)** or Fieldbus commands **(f)**.

Atos PC software allows to realize an automatic cycle according to the application requirements. Refer to the axis card user manual for further details on automatic cycle features.

Automatic cycle

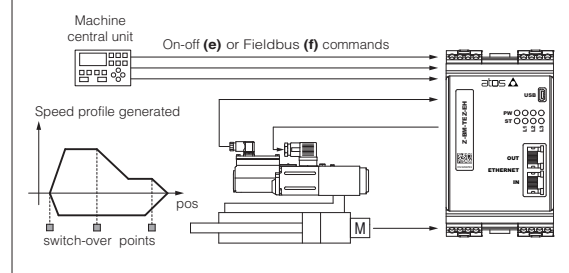

5 ALTERNATED POSITION / FORCE CONTROL

The alternated pressure or force closed loop control can be added to the actuator standard position control, requiring one or two remote transducers (pressure or force) that have to be installed on the actuator, see below functional schemes.

The position/force controls are operated according to two separate reference signals and a dedicated algorithm automatically selects which control is active time by time.

The dynamics of the switching between the two controls can be regulated thanks to specific software setting, in order to avoid instability and vibrations.

Position control is active (see phase ① and ③ at side) when the actuator force is lower than the relevant reference signal - the valve controls the actuator position by closed-loop regulation.

Force control is active (see phase ② and ④ at side) when the actuator actual force, measured by remote transducers, grows up to the relevant reference signal - the axis card reduces the valve's regulation in order to limit the actuator force; if the force tends to decrease under its reference signal, the position control returns active.

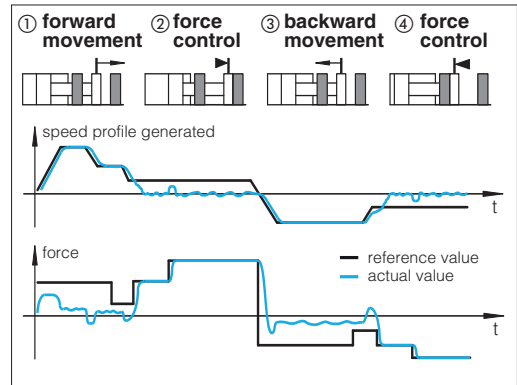

Alternated control configurations - software selectable

SF	SL
<p>two remote pressure transducers have to be installed on the actuator's ports; the actuator force is calculated by the pressure feedbacks ($P_a - P_b$)</p>	<p>one load cell transducer has to be installed between the actuator and the controlled load</p>
<p>T valve's spool transducer M actuator's position transducer P pressure transducer L load cell</p>	

SF – position/force control

Adds force control to standard position control and permits to limit the max force in two directions controlling in closed loop the delta pressure acting on both sides of the hydraulic actuator. Two pressure transducers have to be installed on both hydraulic line.

SL – position/force control

Adds force control to standard position control and permits to limit the max force in one or two directions controlling in closed loop the force performed by the hydraulic actuator. A load cell has to be installed on hydraulic actuator.

General Notes:

- servoproportional type DLHZO, DLKZOR and DPZO-L are strongly recommended for high accuracy applications see tech tables **F180**, **F175**
- auxiliary check valves are recommended in case of specific hydraulic configuration requirements in absence of power supply or fault, see tech table **EY105**
- for additional information about alternated P/Q controls configuration please refer to tech table **FS500**
- Atos technical service is available for additional evaluations related to specific applications usage

6 APPLICATION EXAMPLES

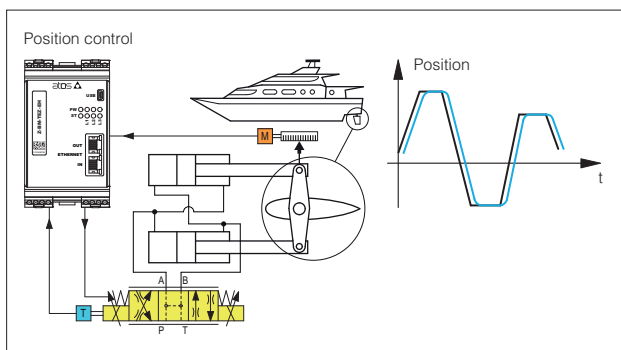

Hydraulic steering wheel in marine applications

Rudder controls on motor yachts and sail boats requires smooth control for precise and reliable operations.

Z-BM-TEZ/LEZ axis cards perform the rudder position control system, ensuring accurate and repetitive regulations for a comfortable ride, thanks to:

- analog position reference mode for real time controls
- analog position transducer for simple and compact solution
- position PID control parameters to optimize the system response
- complete diagnostic information for advanced system monitoring

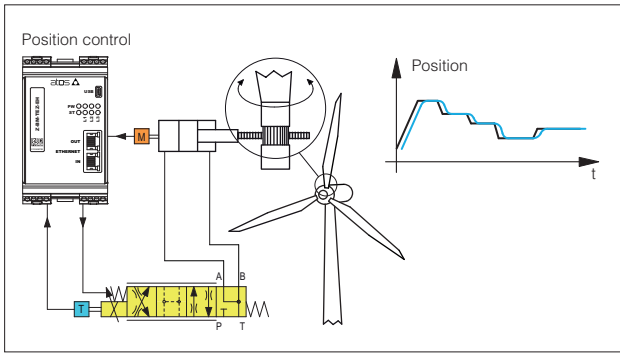

Wind turbines

The pitch control of the rotor blades is required to maximize the energy production. Accurate positioning, decentralized intelligence as well as long service life and reliability are required.

Z-BM-TEZ/LEZ axis cards perform high quality regulation of the blade pitch simplifying the system architecture, thanks to:

- SSI digital position transducer for high precision control
- complete remote system management with fieldbus interface
- position PID selection to adapt the position control to the different wind conditions

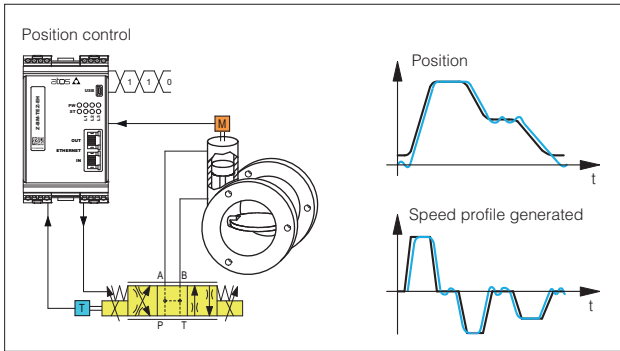

Process valves

Process valves motion regulation requires smooth and remote controls due to wide distributed applications.

Z-BM-TEZ/LEZ axis cards allow remote control, thanks to:

- internal reference generation with maximum speed and acceleration settings for standing alone axis control
- potentiometer position transducer for compact and cost effective solution
- fieldbus connection for easy parameterization and remote commands

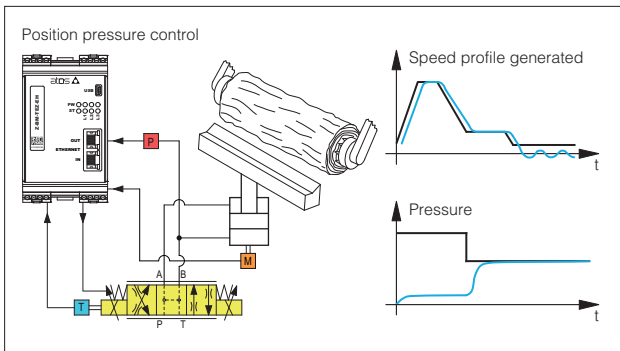

Wood machinery

Hydraulic wood machines require configurable and repetitive motion profiles, accurate position controls, and digital signals for synchronization purpose.

Z-BM-TEZ/LEZ axis cards allow remote control, thanks to:

- internal reference generation with maximum speed and acceleration settings
- analog position transducer for simple and reliable solution
- pressure transducer for alternated pressure control
- fieldbus connection for remote parameterization, commands, and axis card state indication

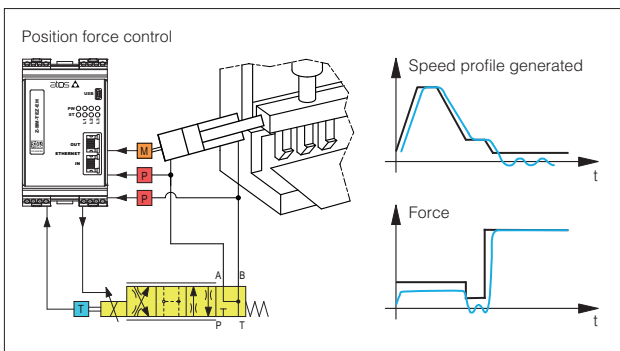

Bending Machines

Machine tools for cold-forming flat sheets require complete, automatic, programmable and flexible machine control to produce sheet metal panels from punched blank.

Z-BM-TEZ/LEZ axis cards combine high level position regulation with accurate force control to provide in a single device a complete and dedicated solution, thanks to:

- internal reference generation to simplify the machine control cycle
- digital position sensor for high resolution measurement system
- two pressure transducers for alternated force control
- fieldbus interface for easy machine control integration
- auxiliary digital outputs for system status indication (target reached, force control active)

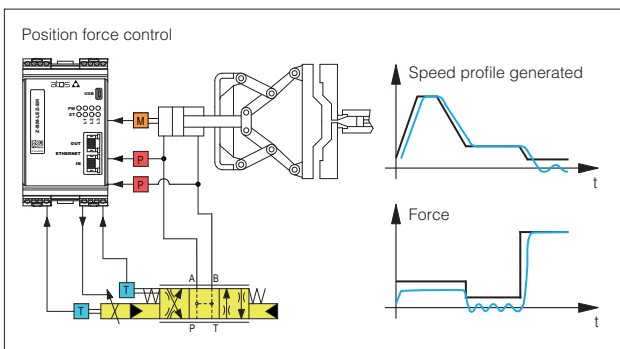

Die-casting machinery

Clamp movements in die-casting phases involve fast/slow motion cycle with accurate and repetitive alternated position/force controls for the mould safety functions.

Z-BM-TEZ/LEZ axis cards, with alternated position/force control, simplify the hydraulic + electronic system architecture, thanks to:

- internal reference generation for repetitive working cycles
- SSI digital position transducer for accurate axis control
- two pressure transducers for alternated force control
- auxiliary digital inputs/output to synchronize the machine functions
- fieldbus connection for machine remote control and advanced diagnostics

7 MAIN CHARACTERISTICS

Power supplies (see 10.1, 10.2)	Nominal : +24 V _{dc} Rectified and filtered : V _{RMS} = 20 ÷ 32 V _{MAX} (ripple max 10 % V _{FP})			
Max power consumption	50 W			
Current supplied to solenoids	I _{MAX} = 3,0 A for standard axis card I _{MAX} = 2,5 A for ex-proof axis card (IA option)			
Analog input signals (see 10.3, 10.4)	Voltage: range ±10 V _{dc} (24 V _{MAX} tollerant) Input impedance: R _i > 50 kΩ Current: range ±20 mA Input impedance: R _i = 500 Ω			
Monitor outputs (see 10.5, 10.6)	Output range: voltage ±10 V _{dc} @ max 5 mA current ±20 mA @ max 500 Ω load resistance			
Enable input (see 10.7)	Range: 0 ÷ 5 V _{dc} (OFF state), 9 ÷ 24 V _{dc} (ON state), 5 ÷ 9 V _{dc} (not accepted); Input impedance: R _i > 10 kΩ			
Fault output (see 10.8)	Output range: 0 ÷ 24 V _{dc} (ON state > [power supply - 2 V] ; OFF state < 1 V) @ max 50 mA; external negative voltage not allowed (e.g. due to inductive loads)			
Alarms	Solenoid not connected/short circuit, cable break with current reference signal, over/under temperature, position control monitoring, valve spool transducer malfunctions, alarms history storage function			
Position transducers power supply	+24 V _{dc} @ max 100 mA or +5 V _{dc} @ max 100 mA are software selectable			
Pressure/Force transducers power supply	+24 V _{dc} @ max 100 mA			
Format	Plastic box ; IP20 protection degree ; L 35 - H 7,5 mm DIN-rail mounting as per EN60715			
Operating temperature	-20 ÷ +50 °C (storage -25 ÷ +85 °C)			
Mass	Approx. 450 g			
Additional characteristics	8 leds for diagnostic; protection against reverse polarity of power supply			
Compliance	CE according to EMC directive 2014/30/EU (Immunity: EN 61000-6-2; Emission: EN 61000-6-3) RoHS Directive 2011/65/EU as last update by 2015/65/EU REACH Regulation (EC) n°1907/2006			
Communication interface	USB Atos ASCII coding	CANopen EN50325-4 + DS408	PROFIBUS DP EN50170-2/IEC61158	EtherCAT, POWERLINK, EtherNet/IP, PROFINET IO RT / IRT EC 61158
Communication physical layer	not insulated USB 2.0 + USB OTG	optical insulated CAN ISO11898	optical insulated RS485	Fast Ethernet, insulated 100 Base TX
Recommended wiring cable	LiYCY shielded cables: 0,5 mm ² max 50 m for logic - 1,5 mm ² max 50 m for power supply Note: for transducers wiring cable please consult the transducers datasheet			
Max conductor size (see 15)	2,5 mm ²			

Note: a maximum time of 800 ms (depending on communication type) have be considered between the axis card energizing with the 24 V_{dc} power supply and when the valve is ready to operate. During this time the current to the valve coils is switched to zero.

8 CONNECTIONS AND LEDS

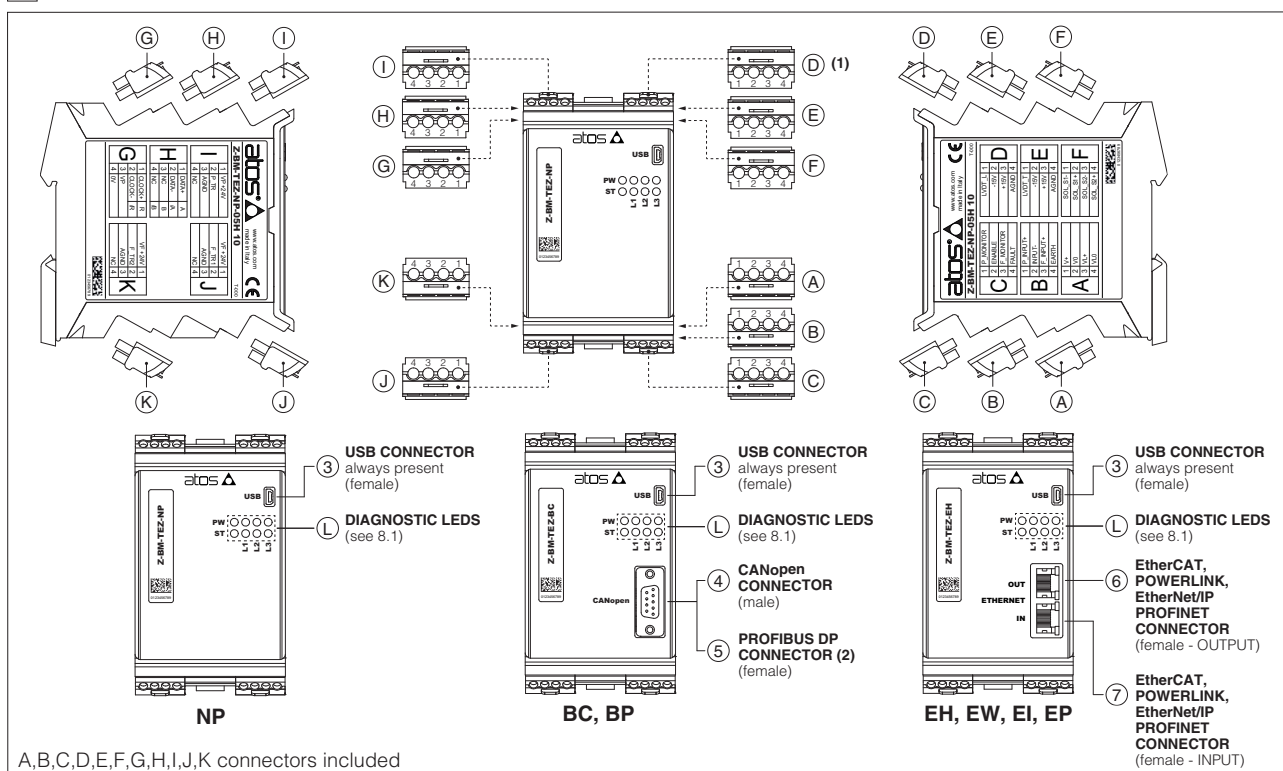

(1) D connector is available only for Z-BM-LEZ-**-01H
(2) To interface with Siemens 6ES7972-0BA12-0XA connector, it is mandatory to use also one of the following adapters to avoid interference with the USB connector: DG909MF1 - the connector will be oriented upwards; DG909MF3 - the connector will be oriented downwards

8.1 Diagnostic LEDs (L)

Eight leds show axis card operative conditions for immediate basic diagnostics. Please refer to the axis card user manual for detailed information.

FIELDBUS LEDS	NP Not Present	BC CANopen	BP PROFIBUS DP	EH EtherCAT	EW POWERLINK	EI EtherNet/IP	EP PROFINET	PW L1 L2 L3
L1	VALVE STATUS			LINK/ACT				
L2	NETWORK STATUS			NETWORK STATUS				
L3	SOLENOID STATUS			LINK/ACT				
PW	OFF = Power supply OFF			ON = Power supply ON				
ST	OFF = Fault present			ON = No fault				

8.2 Connectors - 4 pin

CONNECTOR	PIN	SIGNAL	TECHNICAL SPECIFICATIONS	NOTES
A	A1	V+	Power supply 24 Vdc (see 10.1)	Input - power supply
	A2	V0	Power supply 0 Vdc (see 10.1)	Gnd - power supply
	A3	VL+	Power supply 24 Vdc for axis card logic and communication (see 10.2)	Input - power supply
	A4	VL0	Power supply 0 Vdc for axis card logic and communication (see 10.2)	Gnd - power supply
B	B1	P_INPUT+	Position reference input signal: ± 10 Vdc / ± 20 mA maximum range. default is ± 10 Vdc (see 10.3)	Input - analog signal Software selectable
	B2	INPUT-	Negative reference input signal for P_INPUT+ and F_INPUT+	Input - analog signal
	B3	F_INPUT+	Force reference input signal (SF, SL controls): ± 10 Vdc / ± 20 mA maximum range; default is ± 10 Vdc (see 10.4)	Input - analog signal Software selectable
	B4	EARTH	Connect to system ground	
C	C1	P_MONITOR	Position monitor output signal: ± 10 Vdc / ± 20 mA maximum range, referred to AGND; default is ± 10 Vdc (see 10.5)	Output - analog signal Software selectable
	C2	ENABLE	Enable (24 Vdc) or disable (0 Vdc) the axis card, referred to VL0 (see 10.7)	Input - on/off signal
	C3	F_MONITOR	Force (SF, SL controls) or valve spool position (SN control) monitor output signal: ± 10 Vdc / ± 20 mA maximum range, referred to AGND; default is ± 10 Vdc (see 10.6)	Output - analog signal Software selectable
	C4	FAULT	Fault (0 Vdc) or normal working (24 Vdc), referred to VL0 (see 10.8)	Output - on/off signal
D ⁽¹⁾	D1	LVDT_L	Main stage valve LVDT position transducer signal (see 10.11)	Input - analog signal
	D2	-15V	Main stage valve LVDT position transducer power supply -15V	Output power supply
	D3	+15V	Main stage valve LVDT position transducer power supply +15V	Output power supply
	D4	AGND	Common gnd for transducer power supply and monitor outputs	Common gnd
E	E1	LVDT_T	Direct valve or pilot valve LVDT position transducer signal (see 10.11)	Input - analog signal
	E2	-15V	Direct valve or pilot valve LVDT position transducer power supply -15V	Output power supply
	E3	+15V	Direct valve or pilot valve LVDT position transducer power supply +15V	Output power supply
	E4	AGND	Common gnd for transducer power supply and monitor outputs	Common gnd
F	F1	SOL_S1-	Negative current to solenoid S1	Output - power PWM
	F2	SOL_S1+	Positive current to solenoid S1	Output - power PWM
	F3	SOL_S2-	Negative current to solenoid S2	Output - power PWM
	F4	SOL_S2+	Positive current to solenoid S2	Output - power PWM
G	G1		Digital position transducer SSI or Encoder is software selectable: - SSI connections see 8.3 - Encoder connections see 8.4	
	G2			
	G3			
	G4			
H	H1		Digital position transducer SSI or Encoder is software selectable: - SSI connections see 8.3 - Encoder connections see 8.4	
	H2			
	H3			
	H4			
I	I1	VP	Power supply: +24Vdc, +5Vdc or OFF (default OFF)	Output - power supply Software selectable
	I2	P_TR1	Analog position transducer input signal ± 10 Vdc / ± 20 mA maximum range; default is ± 10 Vdc (see 10.9)	Input - analog signal Software selectable
	I3	AGND	Common gnd for transducer power supply and signals	Common gnd
	I4	NC	Do not connect	
J	J1	VF +24V	Power supply: +24Vdc or OFF (default OFF)	Output - power supply Software selectable
	J2	F_TR1	1st signal pressure/force transducer: ± 10 Vdc / ± 20 mA maximum range; default is ± 10 Vdc (see 10.10)	Input - analog signal Software selectable
	J3	AGND	Common gnd for transducer power supply and signals	Common gnd
	J4	NC	Do not connect	
K	K1	VF +24V	Power supply: +24Vdc or OFF (default OFF)	Output - power supply Software selectable
	K2	F_TR2	2nd signal pressure transducer (only for SF): ± 10 Vdc / ± 20 mA maximum range; default is ± 10 Vdc (see 10.10)	Input - analog signal Software selectable
	K3	AGND	Common gnd for transducer power supply and signals	Common gnd
	K4	NC	Do not connect	

(1) D connector is available only for Z-BM-LEZ-**-01H

8.3 SSI connectors signals - 4 pin

G	G1	CLOCK+	Serial synchronous clock (+)	Output - on/off signal
	G2	CLOCK-	Serial synchronous clock (-)	Output - on/off signal
	G3	VP	Power supply: +24Vdc, +5Vdc or OFF (default OFF)	Output - power supply Software selectable
	G4	0V	Common gnd for transducer power and signals	Common gnd
H	H1	DATA+	Serial position data (+)	Input - on/off signal
	H2	DATA-	Serial position data (-)	Input - on/off signal
	H3	NC	Do not connect	
	H4	NC	Do not connect	

Note: for Balluff BTL7 with SSI interface only special code SA433 is supported

SSI connection - example

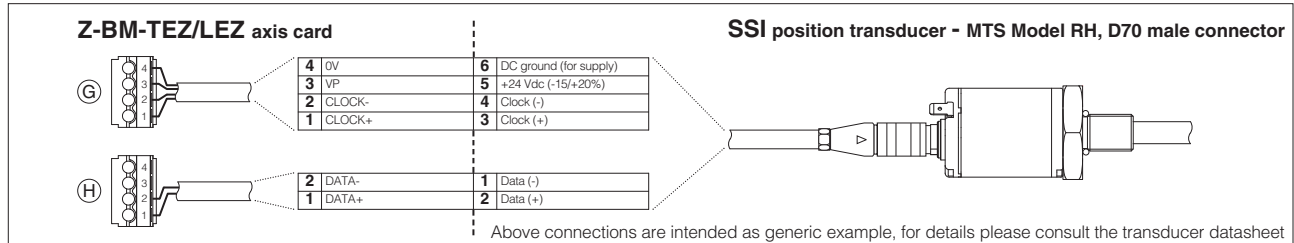

8.4 Encoder connectors signals - 4 pin

G	G1	R	Input channel R	Input - on/off signal
	G2	/R	Input channel /R	Input - on/off signal
	G3	VP	Power supply: +24Vdc, +5Vdc or OFF (default OFF)	Output - power supply Software selectable
	G4	0V	Common gnd for transducer power and signals	Common gnd
H	H1	A	Input channel A	Input - on/off signal
	H2	/A	Input channel /A	Input - on/off signal
	H3	B	Input channel B	Input - on/off signal
	H4	/B	Input channel /B	Input - on/off signal

Encoder connection - example

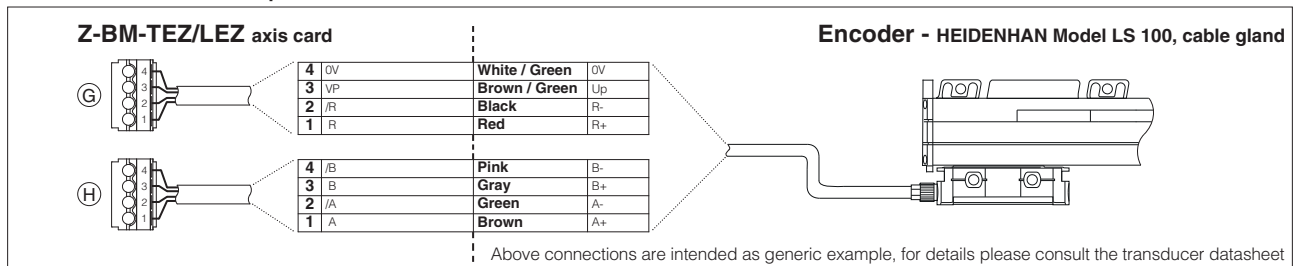

8.5 Pressure/force transducers connection - example

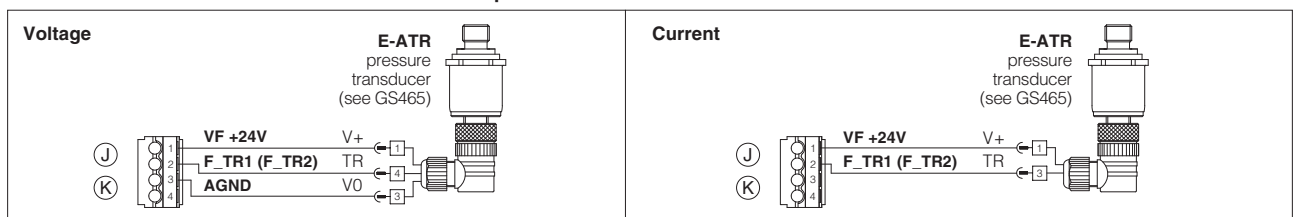

8.6 Communication connectors ③ - ④ - ⑤ - ⑥ - ⑦

③ USB connector - Mini USB type B always present		
PIN	SIGNAL	TECHNICAL SPECIFICATION (1)
1	+5V_USB	Power supply
2	D-	Data line -
3	D+	Data line +
4	ID	Identification
5	GND_USB	Signal zero data line

⑤ BP fieldbus execution, connector - DB9 - 9 pin		
PIN	SIGNAL	TECHNICAL SPECIFICATION (1)
1	SHIELD	
3	LINE-B	Bus line (low)
5	DGND	Data line and termination signal zero
6	+5V	Termination supply signal
8	LINE-A	Bus line (high)

④ BC fieldbus execution, connector - DB9 - 9 pin		
PIN	SIGNAL	TECHNICAL SPECIFICATION (1)
2	CAN_L	Bus line (low)
3	CAN_GND	Signal zero data line
5	CAN_SHLD	Shield
7	CAN_H	Bus line (high)

⑥ ⑦ EH, EW, EI, EP fieldbus execution, connector - RJ45 - 8 pin		
PIN	SIGNAL	TECHNICAL SPECIFICATION (1)
1	TX+	Transmitter - white/orange
2	TX-	Transmitter - orange
3	RX+	Receiver - white/green
6	RX-	Receiver - green

(1) Shield connection on connector's housing is recommended

9 SET CODE

The basic calibration of axis card is factory preset, according to the proportional valve to be coupled. These pre-calibrations are identified by the set code at the end of axis card model code (see section 1). For correct set code selection, please include in the axis card order also the complete code of the coupled proportional valve. For further information about set code, please contact Atos technical office.

10 POWER SUPPLY AND SIGNALS SPECIFICATIONS

Atos digital axis card are CE marked according to the applicable directives (e.g. Immunity and Emission EMC Directive). Installation, wirings and start-up procedures must be performed according to the general prescriptions shown in tech table **FS900** and in the user manuals included in the Z-SW programming software.

Generic electrical output signals of the valve (e.g. fault or monitor signals) must not be directly used to activate safety functions, like to switch-ON/OFF the machine's safety components, as prescribed by the European standards (Safety requirements of fluid technology systems and components-hydraulics, ISO 4413).

10.1 Power supply (V+ and V0)

The power supply (pin A1 and A2) must be appropriately stabilized or rectified and filtered: apply at least a 10000 μ F/40 V capacitance to single phase rectifiers or a 4700 μ F/40 V capacitance to three phase rectifiers.

 A safety fuse is required in series to each power supply: 2,5 A time lag fuse.

10.2 Power supply for axis card logic and communication (VL+ and VL0)

The power supply (pin A3 and A4) for axis card logic and communication must be appropriately stabilized or rectified and filtered: apply at least a 10000 μ F/40 V capacitance to single phase rectifiers or a 4700 μ F/40 V capacitance to three phase rectifiers.

The separate power supply for axis card logic, allow to remove solenoid power supply from pin A1 and A2 maintaining active the diagnostics, USB and fieldbus communications.

 A safety fuse is required in series to each axis card logic and communication power supply: 500 mA fast fuse.

10.3 Position reference input signal (P_INPUT+)

Functionality of P_INPUT+ signal (pin B1), depends on axis card reference mode, see section 4:

external analog reference (see 4.1): input is used as reference for control in closed loop the actuator position.

Input signal can be reconfigured via software selecting between voltage and current, within a maximum range of ± 10 V_{bc} or ± 20 mA; default is ± 10 V_{bc}

external fieldbus reference (see 4.1) or *automatic cycle* (see 4.2): analog reference input signal can be used as on-off commands with input range 0 ÷ 24V_{bc}.

10.4 Force reference input signal (F_INPUT+)

Functionality of F_INPUT+ signal (pin B3), depends on selected axis card reference mode and alternated control options, see section 5:

SL, SF controls and external analog reference selected: input is used as reference for the axis card pressure/force closed loop.

Input signal can be reconfigured via software selecting between voltage and current, within a maximum range of ± 10 V_{bc} or ± 20 mA; default is ± 10 V_{bc}

SN control or fieldbus reference selected: analog reference input signal can be used as on-off commands with input range 0 ÷ 24V_{bc}

10.5 Position monitor output signal (P_MONITOR)

The axis card generates an analog output signal (pin C1) proportional to the actual axis position; the monitor output signal can be software set to show other signals available in the axis card (e.g. analog reference, fieldbus reference, position error, valve spool position).

The output range and polarity are software selectable within the maximum range ± 10 V_{bc} or ± 20 mA; default is ± 10 V_{bc}

10.6 Force monitor output signal (F_MONITOR)

The axis card generates an analog output signal (pin C3) according to alternated force control option:

SN control: output signal is proportional to the actual valve spool position

SL, SF controls: output signal is proportional to the actual pressure/force applied to the cylinder's rod end

Monitor output signals can be software set to show other signals available in the axis card (e.g. analog reference, force reference).

The output range and polarity are software selectable within the maximum range ± 10 V_{bc} or ± 20 mA; default is ± 10 V_{bc}

10.7 Enable Input Signal (ENABLE)

To enable the axis card, a 24V_{bc} voltage has to be applied on pin C2

When the Enable signal is set to zero the axis card can be software set to perform one of the following actions:

- maintain the actuator actual position in close loop control
- move towards a predefined position in closed loop control and maintains the reached position (hold position)
- move forward or backward in open loop (only the valve's closed loop remain active)

10.8 Fault output signal (FAULT)

Fault output signal (pin C4) indicates fault conditions of the axis card (solenoid short circuits/not connected, reference or transducer signal cable broken, maximum error exceeded, etc.). Fault presence corresponds to 0 V_{bc}, normal working corresponds to 24 V_{bc}

Fault status is not affected by the status of the Enable input signal.

Fault output signal can be used as digital output by software selection.

10.9 Position transducer input signals

A position transducer must be always directly connected to the axis card. Position digital input signals are factory preset to binary SSI, they can be reconfigured via software selecting between binary/gray SSI, Encoder or generic transducer with analog interface.

Input signals can be reconfigured via software selecting between voltage and current, within a maximum range of ± 10 V_{bc} or ± 20 mA; default is ± 10 V_{bc}

Refer to position transducer characteristics to select the transducer type according to specific application requirements, see section 11.

10.10 Remote pressure/force transducer input signals (F_TR1 and F_TR2) - SF, SL controls

Analog remote pressure transducers or load cell can be directly connected to the axis card.

Input signal can be reconfigured via software selecting between voltage and current, within a maximum range of ± 10 V_{bc} or ± 20 mA; default is ± 10 V_{bc}

Refer to pressure/force transducer characteristics to select the transducer type according to specific application requirements, see section 11.

10.11 Main stage and direct or pilot position transducer input signals (LVDT_L and LVDT_T)

Main stage (LVDT_L pin D1) and direct or pilot (LVDT_T pin E1) position transducer integrated to the valve have to be directly connected to the axis card using ± 15 V_{bc} supply output available at pin D2, D3 and pin E2, E3.

Note: transducer input signals working range is ± 10 V_{bc} for standard or 4 ÷ 20 mA for /C option and **cannot** be reconfigured via software (input signals setting depends to the axis card set code).

10.12 Possible combined options: /AC

11 ACTUATOR'S TRANSDUCER CHARACTERISTICS

11.1 Position transducers

The accuracy of the position control is strongly dependent to the selected position transducer. Four different transducer interfaces are available on the axis cards, depending to the system requirements: analog signal (analog), SSI or Encoder (digital). Transducers with digital interface allow high resolution and accurate measures, that combined with fieldbus communication grants highest performances. Transducers with analog interface grant simple and cost effective solutions.

11.2 Pressure/force transducers

The accuracy of the pressure/force control is strongly dependent to the selected pressure/force transducer (see section 5). Alternated force controls require to install pressure transducers or load cell to measure the actual pressure/force values.

Pressure transducers allow easy system integration and cost effective solution for alternated position/force controls (see tech table **GS465** for pressure transducers details). Load cell transducers allow the user to get high accuracy and precise regulations for alternated position/force control.

The characteristics of the remote pressure/force transducers must be always selected to match the application requirements and to obtain the best performances: transducer nominal range should be at least 115%÷120% of the maximum regulated pressure/force.

11.3 Transducers characteristics & interfaces - following values are just for reference, for details please consult the transducer's datasheet

	Position			Pressure/Force
Input type	Analog	SSI (3)	Incremental Encoder	Analog
Power supply (1)	+24 Vdc	+5 Vdc or +24 Vdc	+5 Vdc or +24 Vdc	+24 Vdc
Axis card interface	0 ÷ 10V or 4 ÷ 20 mA	Serial SSI binary/gray	TTL 5Vpp - 150 KHz	±10 Vdc or 4 ÷ 20 mA
Max speed	1 m/s	2 m/s	2 m/s	-
Max resolution	< 0.2 % FS	1 µm	1 µm (@ 0.15 m/s)	< 0.4 % FS
Linearity error (2)	< ±0.03% FS	< ± 0.01 % FS	< ± 0.001 % FS	< ±0.25% FS
Repeatability (2)	< ± 0.005% FS	< ± 0.001 % FS	< ± 0.001 % FS	< ±0.1% FS

(1) power supply provided by Atos axis card (2) percentage of total stroke (3) for Balluff BTL7 with SSI interface only special code SA433 is supported

12 VALVE SETTINGS AND PROGRAMMING TOOLS

Valve's functional parameters and configurations, can be easily set and optimized using Atos Z-SW programming software connected via USB port to the digital axis card (see table **FS900**). For fieldbus versions, the software permits valve's parameterization through USB port also if the axis card is connected to the central machine unit via fieldbus.

The software is available in different versions according to the axis card options (see table **GS500**):

Z-SW-FULL support: NP (USB) PS (Serial)
 BC (CANopen) BP (PROFIBUS DP) EH (EtherCAT)
 EW (POWERLINK) EI (EtherNet/IP) EP (PROFINET)

WARNING: axis card USB port is not isolated! For E-C-SB-USB/BM cable, the use of isolator adapter is highly recommended for PC protection

WARNING: see tech table **GS500** for the list of countries where the Bluetooth adapter has been approved

DVD programming software, to be ordered separately:

Z-SW-FULL DVD first supply = software has to be activated via web registration at www.atos.com; 1 year service included
 Upon web registration user receive via email the Activation Code (software license) and login data to access Atos Download Area

Z-SW-FULL-N DVD next supplies = only for supplies after the first; service not included, web registration not allowed
 Software has to be activated with Activation Code received upon first supply web registration

Atos Download Area: direct access to latest releases of Z-SW software, manuals, USB drivers and fieldbus configuration files at www.atos.com

USB Adapters, Cables and Terminators, can be ordered separately

USB or Bluetooth connection

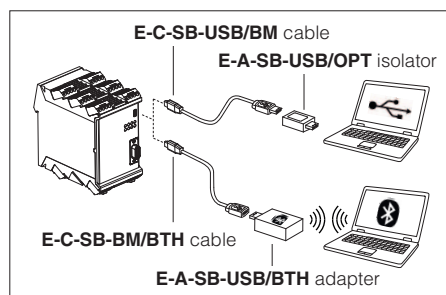

13 MAIN SOFTWARE PARAMETER SETTINGS

For a detailed descriptions of the available settings, wirings and installation procedures, please refer to the user manuals included in the Z-SW programming software:

Z-MAN-BM-LEZ - user manual for **Z-BM-LEZ** and **Z-BM-TEZ**

13.1 External reference and transducer parameters

Allow to configure the axis card reference and transducer inputs, analog or digital, to match the specific application requirements:

- *Scaling parameters* define the correspondence of these signals with the specific actuator stroke or force to be controlled
- *Limit parameters* define maximum/minimum stroke and force to detect possible alarm conditions
- *Homing parameters* define the startup procedure to initialize incremental transducer (e.g. Encoder)

13.2 PID control dynamics parameters

Allow to optimize and adapt the axis card closed loop to the wide range of hydraulic system characteristics:

- *PID parameters* each part of the closed loop algorithm (proportional, integral, derivative, feed forward, fine positioning, etc) can be modified to match the application requirements

13.3 Monitoring parameters

Allow to configure the axis card monitoring function of the positioning error (difference between actual reference and feedback) and detects anomalous conditions:

- *Monitoring parameters* maximum allowed errors can be set for both static and dynamic positioning phases, and dedicated waiting times can be set to delay the activation of the alarm condition and relevant reaction (see 13.4)

13.4 Fault parameters

Allow to configure how the axis card detect and react to alarm conditions:

- *Diagnostics parameters* define different conditions, threshold and delay time to detect alarm conditions
- *Reaction parameters* define different actions to be performed in case of alarm presence (stop at actual or preprogrammed position, emergency forward/backward, axis card disabling, etc.)

13.5 Valve characteristics compensation

Allow to modify the valve regulation to match the actuator/system characteristics and to obtain the best overall performances:

- *Valve parameters* modify the standard valve regulation by means of deadband compensation, curve linearization and differentiated gain for positive and negative regulation

13.6 Motion phases parameters

When the internal reference generation is active a pre-programmed cycle can be generated; start/stop/switch-over commands and reference generation types parameters can be set to design a customized sequence of motion phases adapted to the specific application requirements (see 4.2).

14 OVERALL DIMENSIONS [mm]

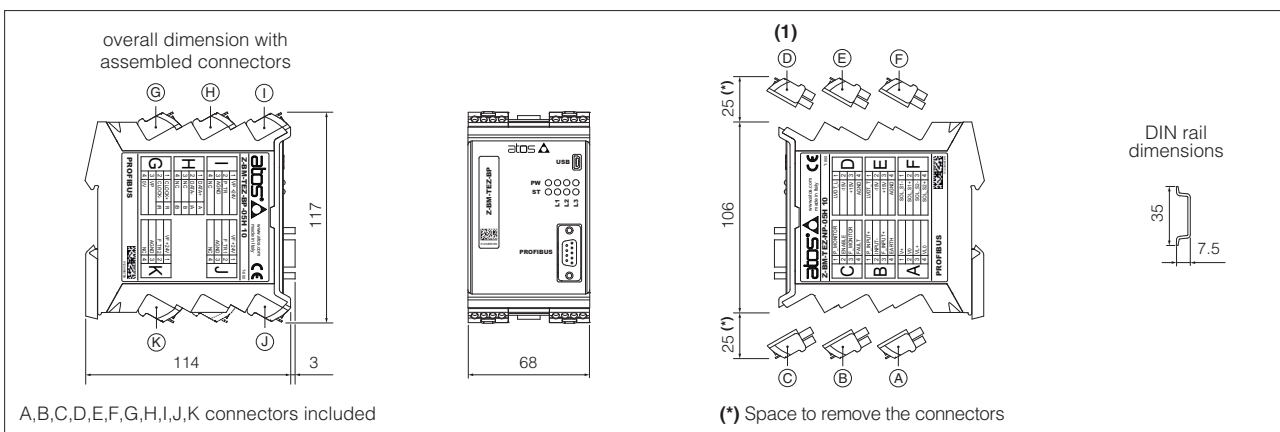

15 INSTALLATION

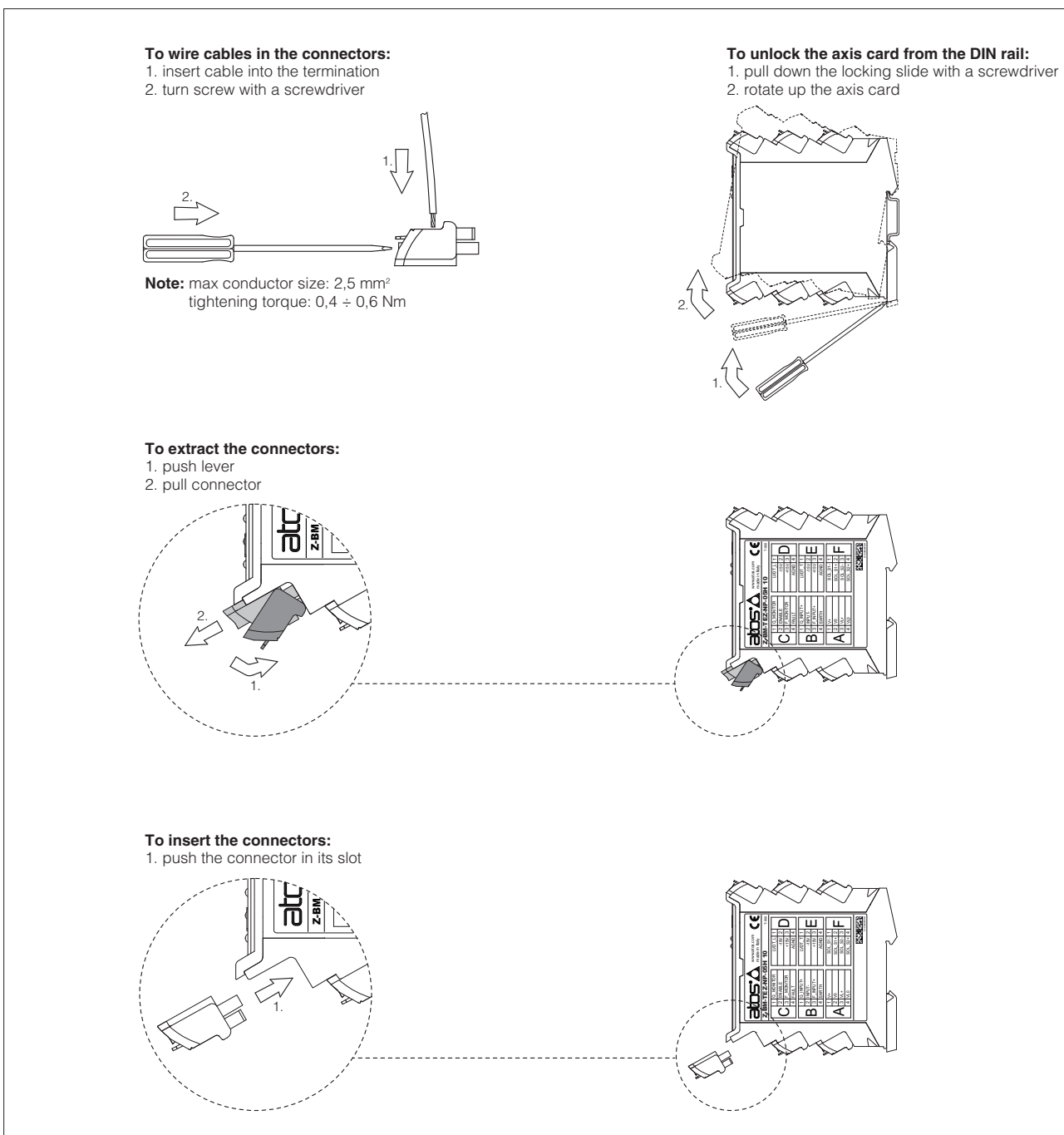

Note: all connectors are supplied with a mechanical coding. This feature ensures a unique insertion of each connector in the own slot. (eg. connector A can not be inserted into connector slot of B,C,D,E,F,G,H,I,J,K)

16 WIRING EXAMPLES

16.1 Position control - analog reference - analog position transducer

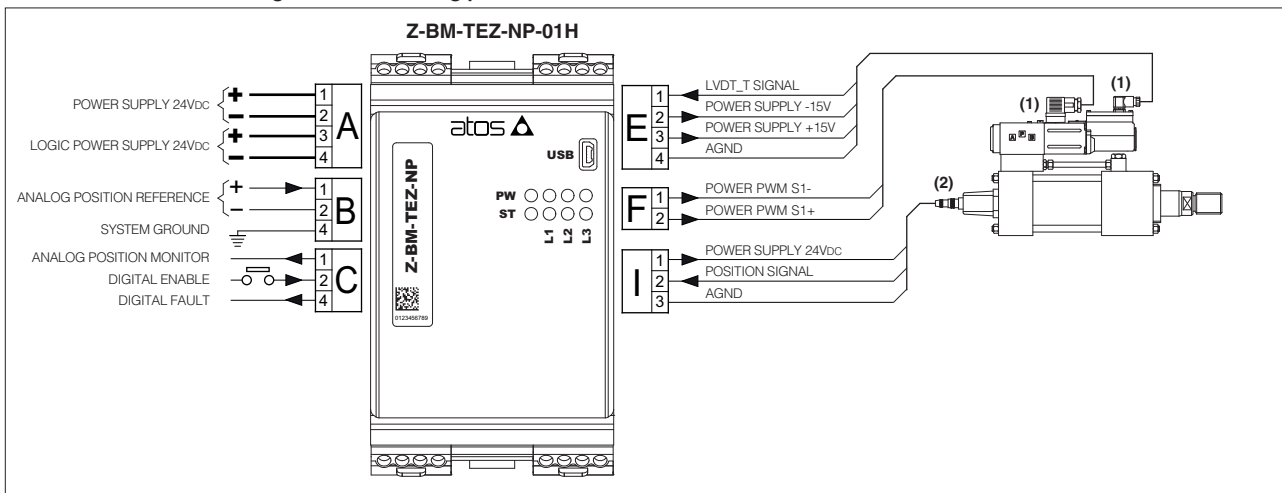

- (1) For valve electrical connections please refer to the specific technical table
- (2) The analog position transducer connections are intended as generic example, for details please consult the transducer datasheet

16.2 Alternated position/force control - CANopen reference - SSI position transducer - 2 analog pressure transducers

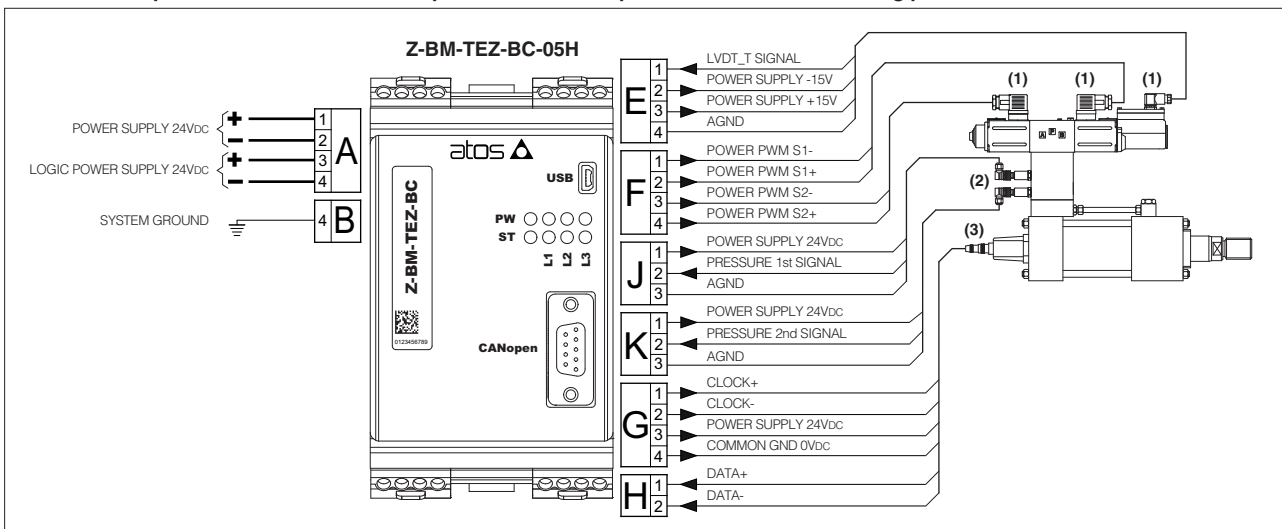

- (1) For valve electrical connections please refer to the specific technical table
- (2) Pressure transducers connections are shown with voltage signal output; for connections with current signal output see 8.5
- (3) The SSI position transducer connections are intended as generic example, for details please consult the transducer datasheet

16.3 Alternated position/force control - EtherNet/IP reference - Encoder position transducer - analog load cell

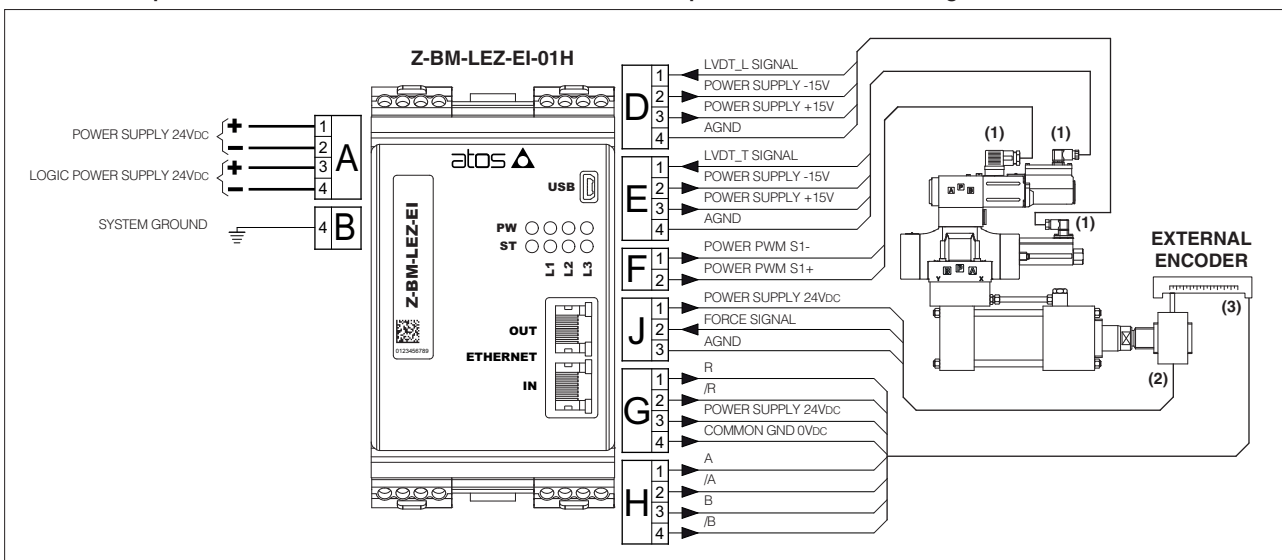

- (1) For valve electrical connections please refer to the specific technical table
- (2) Load cell connections is shown with voltage signal output; please consult the load cell datasheet for details about connections
- (3) The Encoder position transducer connections are intended as generic example, for details please consult the transducer datasheet