

OPTION M-SERIES



Art. no M-SS
Diameter Ø 47 mm
Length 600 mm



Art.no M-DS
Diameter Ø 47 mm
Length 450 mm
CC distance 200 mm



Art. no M-RR
Roll inner dia. Ø 74-80 mm
Roll outer dia. Ø 500 mm
Roll length 250 mm



Art. no E-VB
Size 400x400 mm
Height 80 mm

M100/M200 | Platform, 100/200 kg

Operated by a manual hand winch and a steel wire which gives an accurate and fast lift/lowering function. The automatic brake system ensures a safe lowering. 4 castor wheels. Roll attachment options available.

- **PLATFORM SIZE (LXB): 480 X 600 MM**



PM120 | Forks, 120 kg

The winch stacker has a very low weight compared to the rated lift capacity, therefore it is very handy and easy-to-use for the operator. It is equipped with adjustable forks for half size pallets, hand winch for lifting and lowering. Large sized rubber rear wheels and small front PU castor wheels, hand controlled brake.

- **ADJUSTABLE FORK WIDTH, 345-485 MM**



TECHNICAL INFORMATION

Art.no	PM120	M100	M200
Type	Manual	Manual	Manual
Capacity (kg)	120	100	200
Load center (mm)	200	235	235
Lifting height, min-max (mm)	95-1050	130-1500	130-1500
Lifting speed (mm/360°)	25	30	25
Fork dimensions (LxWxH) (mm)	400x345-485x14	400x330x40	400x330x40
Steering wheel (mm)	Ø200x50	Ø125x50	Ø125x50
Fork wheel (mm)	Ø50x20	Ø75x20	Ø75x20
Dimensions (LxWxH) (mm)	720x485x1360	840x600x1830	840x600x1920
Platform (LxW) (mm)	-	480x600	480x600
Weight (kg)	31	48	70
Price			

E-series | Electronic, 100-200 kg

Very flexible and easy to operate. Designed to relieve back, neck and shoulders from all types of lifting work from floor level up to head level. Lift/lowering system with electrical motor, chain drive, electronic regulation of lift/lowering incl. soft start/stop, electric overload protection, portable and adjustable hand control unit, maintenance free/sealed battery, built-in maintenance charger for the battery, hand control cable and charger cable. Standard support legs are 105 mm high.

- PLATFORM IS MADE OF POLYPROPYLENE



All models are also available with low profile legs (85 mm).
Art. no RE80-Low

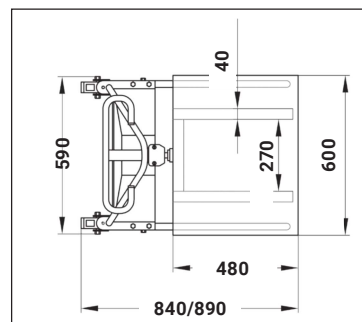
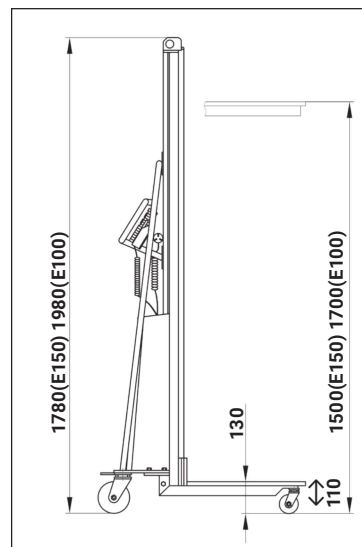

OPTION E-SERIES



Art. no E-SS
Diameter \varnothing 47 mm
Width 600 mm



Art. no E-DS
Diameter \varnothing 47 mm
Width 450 mm
CC distance 200 mm



Art. no E-RR
Roll inner dia. \varnothing 74-80 mm
Roll outer dia. \varnothing 500 mm
Roll width 250 mm



Art. no E-VB
Size 400x400 mm
Height 80 mm

TECHNICAL INFORMATION

Art.no	E100	E100H	E100S	E150	E200
Type	Electronic	Electronic	Electronic, Stainless	Electronic	Electronic
Capacity (kg)	100	100	100	150	200
Load center (mm)	235	235	235	235	235
Lifting height, min-max (mm)	130-1700	130-2000	130-1700	130-1500	130x1500
Lifting speed (mm/s)	50	50	50	50	50
Platform (LxWxT) (mm)	470x600x15	470x600x15	470x600x15	470x600x15	470x600x15
Fork dimensions (LxWxT) (mm)	400x40x40	400x40x40	400x40x40	400x40x40	400x40x40
Battery (V/Ah)	12/24	12/24	12/24	12/24	12/34
Steering wheel / Loading wheel (mm)	\varnothing 125/ \varnothing 75	\varnothing 125/ \varnothing 75	\varnothing 125/ \varnothing 75	\varnothing 125/ \varnothing 75	\varnothing 125/ \varnothing 75
Dimensions (LxWxH) (mm)	840x600x1980	840x600x2280	840x600x1980	840x600x1790	960x600x1790
Weight (kg)	62	65	62	60	75
Price					

* Other accessories and other dimensions on request