



6.3 - VALVOLE UNIDIREZIONALI CON BLOCCO AUTOMATICO (PARACADUTE)

 TIPO/TYPE
VUBA

6.3 - HOSE BURST VALVES CARTRIDGE

 SCHEMA IDRAULICO
 HYDRAULIC DIAGRAM

IMPIEGO:

Valvole utilizzate per prevenire la discesa incontrollata dell'attuatore in caso di rottura della tubazione. All'improvviso aumentare della portata (flusso di reazione) la valvola entra in funzione chiudendo il flusso.

MATERIALI E CARATTERISTICHE:

Corpo: acciaio, brunito.

MONTAGGIO:

Avvitare la valvole nell'apposita cavità collegando V all'alimentazione e C all'attuatore. Se ne consiglia l'uso con una valvola di regolazione flusso.

A RICHIESTA:

- Regolazioni personalizzate (è consigliata una taratura tale che il flusso corrispondente sia almeno 1,5 volte superiore al flusso dell'impianto): specificare la portata (l/min) o la distanza S (mm) tra piattello e valvola.
- Con foro sul piattello (CODICE/F, specificando la dimensione del foro) per la discesa lenta del carico a valvola chiusa
- Valvole complete di manicotto maschio-femmina o femmina-femmina per il montaggio in linea vicino all'attuatore.

USE AND OPERATION:

These valves are used to prevent uncontrolled descent of a load in case of hose failure. When it exceeds the valve setting (reaction flow), the valve block the flow.

MATERIALS AND FEATURES:

Body: steel, burnished

APPLICATIONS:

Screw in the valve connecting V to the pressure flow and C to the actuator. The use together with a flow control valve is recommended.

ON REQUEST

- Preset hose bursts available (the reaction flow should be set 1,5 times more than the rate flow of the system). Please specify flow (lt/min) or distance S (mm) from the flat to the valve
- Hole on the flat (CODE/F, please specify hole dimension) for a slow load descent with closed valve
- Valve completes with male-female or female-female thread body for in line mounting by the actuator

PERDITE DI CARICO PRESSURE DROPS CURVE

Temperatura olio: 50°C - Viscosità olio: 30 cSt
 Oil temperature: 50°C - Oil viscosity: 30 cSt

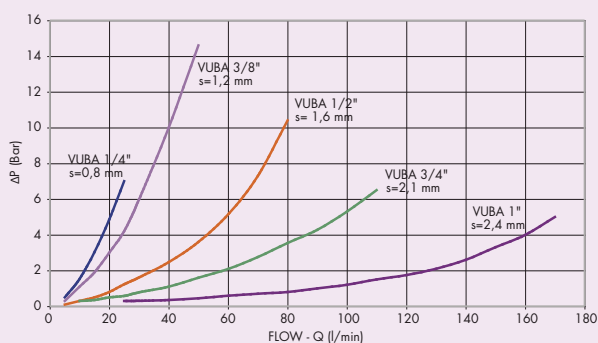

FLUSSO/SPESSORE FLOW/DISTANCE

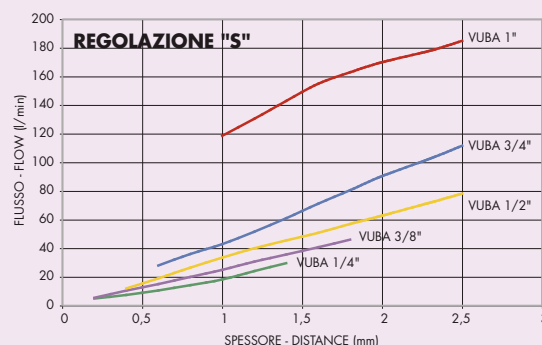



CODICE CODE	SIGLA TYPE	PORTATA MAX MAX FLOW Lt./min	PRESSIONE MAX MAX PRESSURE Bar
V0770	VUBA 1/4"	25	350
V0780	VUBA 3/8"	50	350
V0790	VUBA 1/2"	80	350
V0800	VUBA 3/4"	140	350
V0810	VUBA 1"	180	350

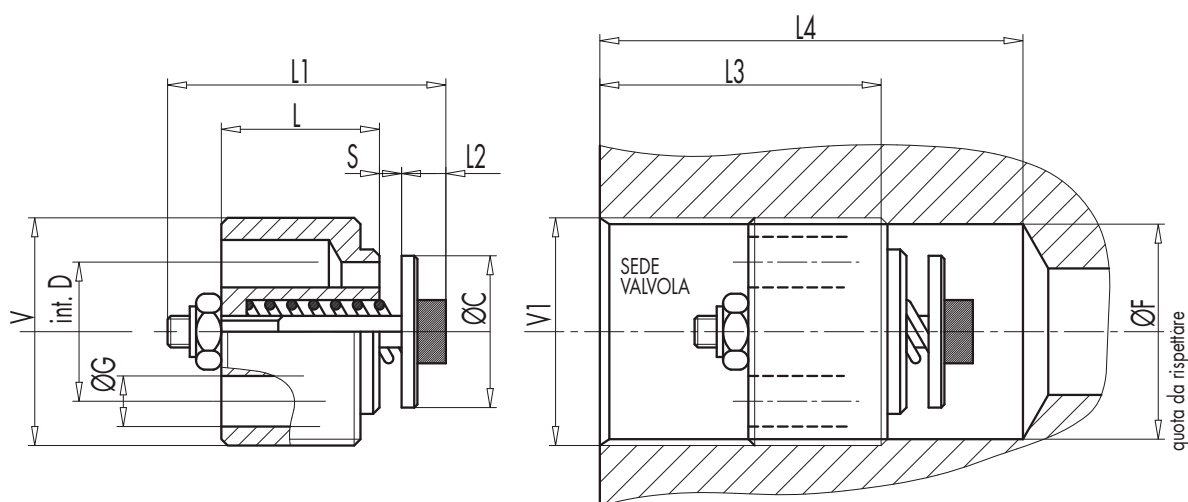

6

CODICE CODE	SIGLA TYPE	V - V1	L	L1	L2	L3	L4	ØC	ØG	ØF	ØD(i)	S	PESO WEIGHT
		GAS	mm	mm	mm	mm	mm	mm	mm	mm	mm	mm	Kg
V0770	VUBA 1/4"	G 1/4"	8	18	5	28	35	9,5	2,5	11,75	8	0,8	0,006
V0780	VUBA 3/8"	G 3/8"	10,5	23	5	31	40	12,5	3,5	15,2	10,5	1,2	0,012
V0790	VUBA 1/2"	G 1/2"	13	29	5	33	43	15	4,5	19	12,5	1,6	0,024
V0800	VUBA 3/4"	G 3/4"	18	34	7	40	53	18,5	6	24,5	16	2,1	0,048
V0810	VUBA 1"	G 1"	20	40	8	43	66	25	7	30,5	19	2,8	0,098

TIPO/TYPE
MFF



CODICE CODE	SIGLA TYPE	V - C	L1	L2	L3	ƒ	PESO
		GAS	mm	mm	mm	mm	Kg
V0771	VUBA 1/4" + MFF	G 1/4"	50	16	28	19	0,072
V0781	VUBA 3/8" + MFF	G 3/8"	58	17	31	24	0,132
V0791	VUBA 1/2" + MFF	G 1/2"	62	18	33	27	0,146
V0801	VUBA 3/4" + MFF	G 3/4"	75	21	40	32	0,220
V0811	VUBA 1" + MFF	G 1"	85	26	43	41	0,452

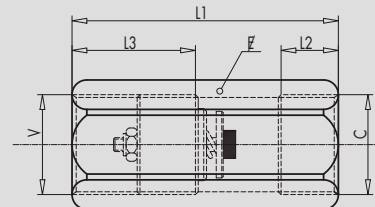

TIPO/TYPE
MMF



CODICE CODE	SIGLA TYPE	V - C	L1	L2	L3	ƒ	PESO
		GAS	mm	mm	mm	mm	Kg
V0772	VUBA 1/4" + MMF	G 1/4"	50	12	28	19	0,064
V0782	VUBA 3/8" + MMF	G 3/8"	58	13	31	24	0,120
V0792	VUBA 1/2" + MMF	G 1/2"	62	14	33	27	0,140
V0802	VUBA 3/4" + MMF	G 3/4"	75	16	40	32	0,228
V0812	VUBA 1" + MMF	G 1"	85	19	43	41	0,456

