

General

This series of cylinders are available in two versions with different threaded fixing holes. The first one includes cylinders from Ø 32 to Ø 100 called "ISO" with fixing holes same as cylinders ISO 6431 - VDMA24562. Cylinders from Ø 20 to Ø 100 called "UNITOP", parts of second series, are mainly according to standard UNITOP RU - P/6 - P/7. Cylinders Ø 12 and Ø 16 non standard, are interchangeable with similar products available in the market. The ISO version uses every fixing devices of series 1320 with exception of intermediate trunnion, while for cylinders Ø 12, Ø 16 and for "UNITOP" version are available fixing devices as flanges, foot, male and female clevis made with aluminum or steel. Every cylinder has the magnetic piston and are available in the most common utilized version such as single and double action, push / pull, male and female piston rod, bored piston rod, non-rotating and tandem versions. Three slots have been realized on three sides of the extruded barrel purposely for the use of magnetic sensors. Standard PNEUMAX sensor can be installed on two out of three slots from Ø 32 to Ø 50 or the miniature sensor with proper adapter on remaining slot. For Ø 63 to Ø 100 the three slots can use standard PNEUMAX sensor. The particular design of the piston allows the use of fixed elastic cushion. Bolted heads so that it is possible to realize cylinders strokes longer than traditional compact cylinders.

Construction characteristics

| | |
|--------------------|--|
| Body | aluminum alloy UNI 9006/1 25 micron anodization |
| Heads | from Ø 12 to Ø 25 aluminum alloy UNI 9006/1 anodized from Ø 32 to Ø 100 UNI 5076 aluminium die-casting and painted (cataphoresys) |
| Piston rod bushing | sintered bronze |
| Piston rod | from Ø 12 to Ø 25 steel AISI 303 chromed, from Ø 32 to Ø 100 C43 chromed (On request stainless steel AISI 303) |
| Piston | from Ø 12 to Ø 25 plated zinc steel from Ø 32 to Ø 100 aluminum alloy 2011 UNI 9002/5 |
| Piston seals | polyurethane U90E. On request THERBAN® |
| Piston rod seal | polyurethane U90E. On request THERBAN® |
| Spring | zinc plated steel for springs |
| Fixing screws | zinc plated steel |

Technical characteristics

| | |
|--------------------------|---|
| Fluid | filtered and lubricated air or non |
| Maximum working pressure | 10 bar |
| Working temperature | -30°C +80°C with polyurethane seals -5°C +120°C with TEHERBAN® seals |

"Attention: Dry air must be used for application below 0°C"

Standard strokes for single acting cylinders

| | |
|------------------|-----------|
| Ø12 | 10mm max. |
| from Ø16 to Ø100 | 25mm max. |

Standard strokes for double acting cylinders

| | |
|-------------|--------------------------|
| Ø12 and Ø16 | from 5 to 40mm every 5mm |
| Ø20 and Ø25 | from 5 to 50mm every 5mm |
| Ø32 to Ø100 | from 5 to 80mm every 5mm |

Maximum suggested strokes

| | |
|--------------|-------|
| Ø12 and Ø16 | 100mm |
| Ø20 and Ø25 | 200mm |
| Ø32 and Ø40 | 300mm |
| Ø50 and Ø63 | 400mm |
| Ø80 and Ø100 | 500mm |

Maximum suggested strokes with non-rotating device

| | |
|------------------|------|
| from Ø12 to Ø25 | 40mm |
| from Ø32 to Ø100 | 80mm |

Minimum and maximum springs load

| | | | | | | | | | | |
|---------------|-----|------|------|------|------|------|------|------|------|-------|
| Bore | 12 | 16 | 20 | 25 | 32 | 40 | 50 | 63 | 80 | 100 |
| Min. load (N) | 3,9 | 4,4 | 4,9 | 9,8 | 12,3 | 16,7 | 27,5 | 37,3 | 59,4 | 101,3 |
| Max. load (N) | 9,3 | 17,7 | 18,1 | 25,5 | 34,3 | 44,1 | 51,0 | 63,8 | 99,4 | 141,9 |

Longer strokes may be utilized if there is no radial loads on piston rod considering there isn't adjustable cushioning system.

Drawing

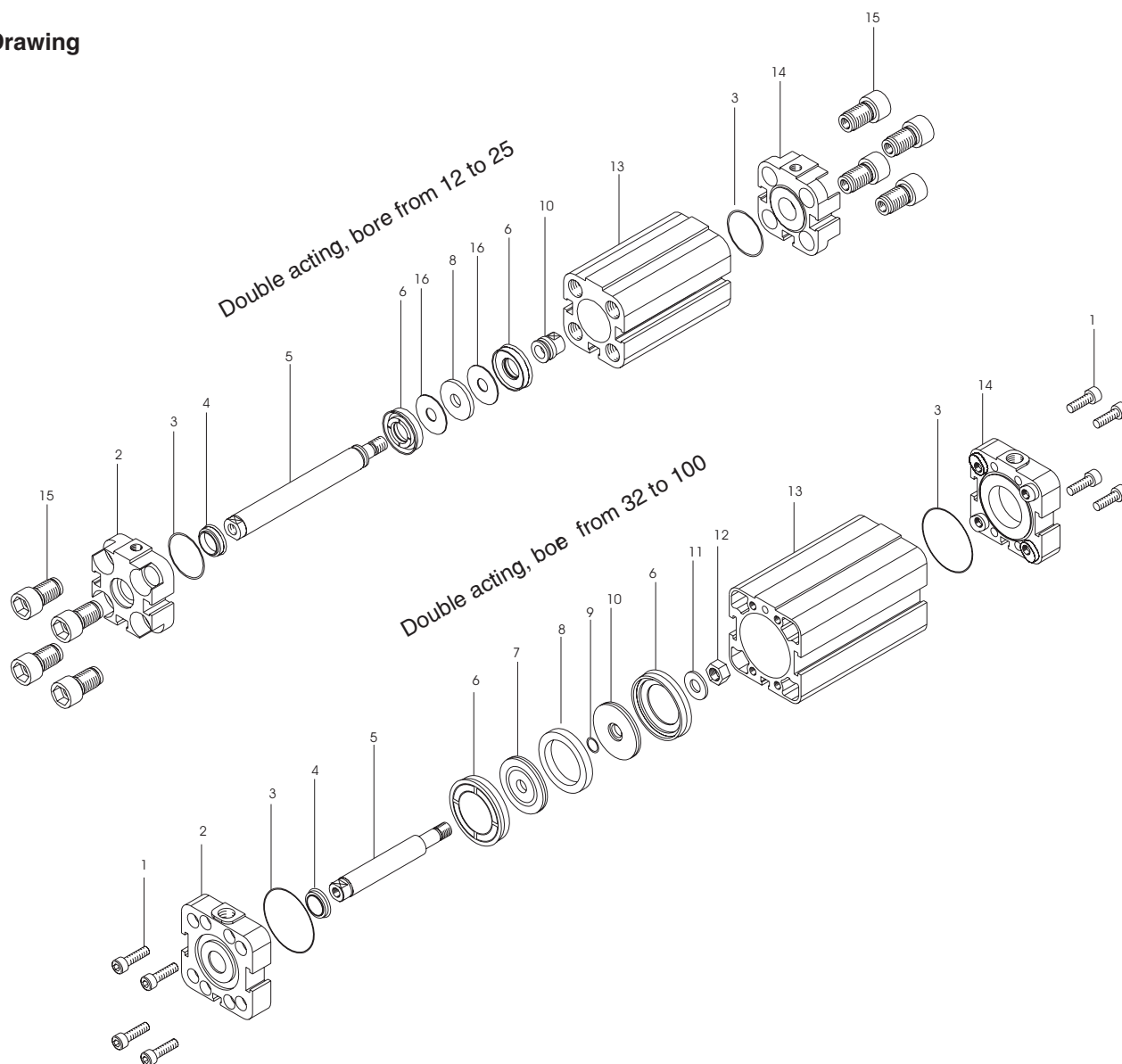

4

| Pos. | Description | N. Pieces |
|------|-------------------|-----------|
| 1 | Screw | * |
| 2 | Front cover assy | 1 |
| 3 | Cover seal | 2 |
| 4 | Piston rod seal | 1 |
| 5 | Piston rod | 1 |
| 6 | Piston seal | 2 |
| 7 | Front half piston | 1 |
| 8 | Magnet | ** |
| 9 | Half piston seal | 1 |
| 10 | Rear half piston | 1 |
| 11 | Washer | 1 |
| 12 | Nut | 1 |
| 13 | Barrel | 1 |
| 14 | Rear cover assy | 1 |
| 15 | Tie rod nut | 8 |
| 16 | Piston washer | 2 |

*Ø 32 ÷ 50 n° 8 - Ø 63 ÷ 100 n° 16 **Ø 12 ÷ 32 n° 1 - Ø 40 ÷ 100 n° 2

Basic version
Basic version single acting



for bore from $\varnothing 12$ to $\varnothing 25$
use sensors series 1580 only

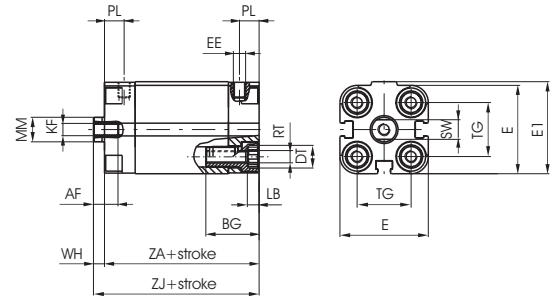

for bore from $\varnothing 32$ to $\varnothing 50$
use sensors series 1500 and 1580 only

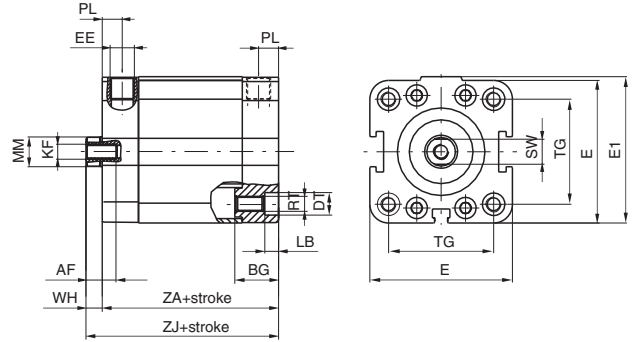

for bore from $\varnothing 63$ to $\varnothing 100$
use sensors series 1500 only
for sensors series 1580 it is required
the adapter code 1580.01.F

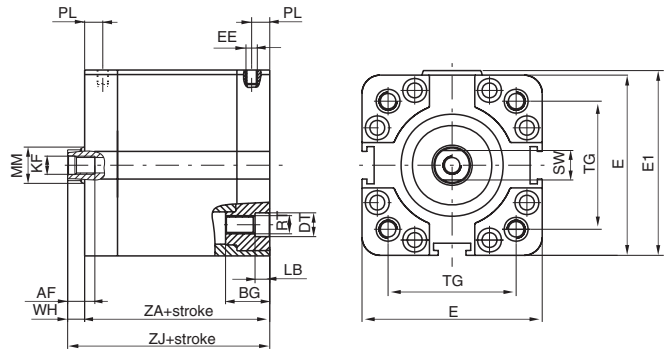

Push/pull version
Push/pull version single acting

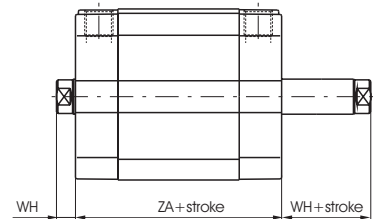

Tandem with opposite rods

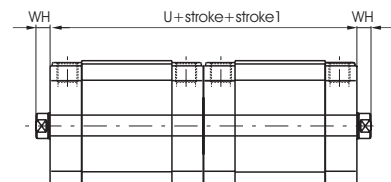

Tandem push with common rods

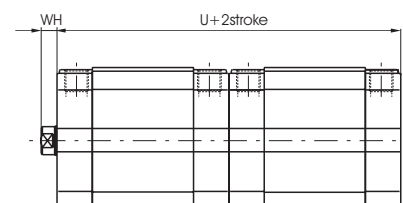



Opposed tandem with common rod

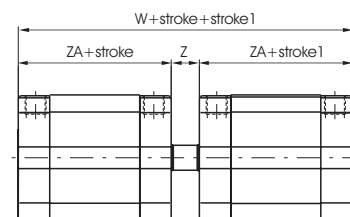

Tandem push with independent rods

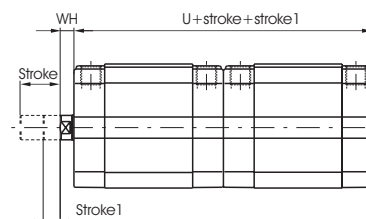

Ordering code

Basic version push/pull

15 . Ø . stroke

- 1 = Double acting
- 2 = Front spring
- 3 = Rear spring
- 01 = Basic version - female piston rod
- 02 = Basic version - male piston rod
- 03 = Push / pull version - female piston rod
- 04 = Push / pull version - male piston rod
- 05 = Push / pull version - bored male piston rod
- 06 = Push / pull version - bored female piston rod
- 07 = Non - rotating version
- 08 = Push / pull version with non rotating device on one side - female piston rod
- 09 = Push / pull version with non rotating device on one side - male piston rod
- 1 = Chromed rod C43 (from Ø12 to Ø25 INOX AISI 303 chromed)
- 2 = AISI 303 chromed stainless steel rod (from Ø32 to Ø 100)
- 6 = ISO (Ø 32 to 100)
- 7 = ISO THERBAN® (Ø 32 to 100)
- 8 = UNITOP (Ø 12 to 100)
- 9 = UNITOP THERBAN® (Ø 12 to 100)

Tandem version

15 . Ø . stroke .(stroke1) . .

- A = Tandem with opposite rods female thread
- E = Tandem with opposite rods male thread
- L = Tandem opposite rods with non rotating device on both sides
- C = Tandem push with common rods female thread
- G = Tandem push with common rods male thread
- H = Tandem push with common rods, push-pull version rod female threads
- N = Tandem push with common rods with non rotating device
- D = Opposed tandem with common rod
- B = Tandem push with independent rods female thread
- F = Tandem push with independent rods male thread
- M = Tandem push with independent rods with non rotating device
- P = Tandem push/pull with independent rods - female thread
- Q = Tandem push/pull with independent rods - male thread
- 1 = Chromed rod C43
- 2 = AISI 303 chromed stainless steel rod
- 6 = ISO (Ø 32 to 100)
- 7 = ISO THERBAN® (Ø 32 to 100)
- 8 = UNITOP (Ø 12 to 100)
- 9 = UNITOP THERBAN® (Ø 12 to 100)

Table of dimensions

| Bore | 12 | 16 | 20 | 25 | 32 | 40 | 50 | 63 | 80 | 100 | |
|------------|------------|------|------|------|--------|--------|--------|--------|--------|--------|------|
| AF | 6 | 8 | 10 | 10 | 12 | 12 | 12 | 12 | 16 | 20 | |
| BG | 19 | 19 | 20 | 20 | 17,5 | 17,5 | 19,5 | 19,5 | 23,5 | 24,5 | |
| DT | 6 | 6 | 8 | 8 | 10 | 9 | 10,5 | 10,5 | 14 | 14 | |
| E | 29 | 29 | 36 | 40 | 48 | 57 | 67 | 80 | 102 | 122 | |
| E1 | 30 | 30 | 37,5 | 41,5 | 49,5 | 58,5 | 69 | 82 | 105 | 125 | |
| EE | M 5 | M 5 | M 5 | M 5 | G 1/8" | G 1/8" | G 1/8" | G 1/8" | G 1/8" | G 1/4" | |
| KF | M 3 | M 4 | M 5 | M 5 | M 6 | M 6 | M 8 | M 8 | M 10 | M 12 | |
| LB | 3,5 | 3,5 | 4,8 | 4,8 | 5,5 | 5,5 | 6,5 | 6,5 | 8,5 | 8,5 | |
| MM | 6 | 8 | 10 | 10 | 12 | 12 | 16 | 16 | 20 | 25 | |
| PL | 8 | 8 | 8 | 8 | 8 | 8 | 8 | 8 | 8,5 | 10,5 | |
| RT | M 4 | M 4 | M 5 | M 5 | M 6 | M 6 | M 8 | M 8 | M 10 | M 10 | |
| SW | 5 | 7 | 8 | 8 | 10 | 10 | 13 | 13 | 17 | 22 | |
| TG ISO | / | / | / | / | 32,5 | 38 | 46,5 | 56,5 | 72 | 89 | |
| TG UNITOP | 18 | 18 | 22 | 26 | 32 | 42 | 50 | 62 | 82 | 103 | |
| U | 76 | 76 | 76 | 79 | 89 | 91 | 91 | 100 | 112 | 133 | |
| W | 85 | 85 | 85 | 90 | 101 | 104 | 106 | 115 | 128 | 153 | |
| WH | 4,5 | 4,5 | 4,5 | 5,5 | 6 | 6,5 | 7,5 | 7,5 | 8 | 10 | |
| Z | 9 | 9 | 9 | 11 | 12 | 13 | 15 | 15 | 16 | 20 | |
| ZA * | 38 | 38 | 38 | 39,5 | 44,5 | 45,5 | 45,5 | 50 | 56 | 66,5 | |
| ZJ * | 42,5 | 42,5 | 42,5 | 45 | 50,5 | 52 | 53 | 57,5 | 64 | 76,5 | |
| Weight gr. | Stroke 0 | 88 | 90 | 140 | 170 | 210 | 320 | 460 | 690 | 1390 | 2290 |
| | every 5 mm | 8 | 8 | 12 | 13 | 15 | 19 | 25 | 31 | 50 | 66 |

* These dimensions increase of 10 mm for cylinders ø 12 front spring version.

Tabular weights above refer to Basic Versions. The weights of Tandem versions are approximately double those shown.



Basic version male piston rod

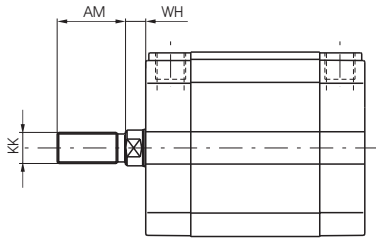

Push - pull version male rod

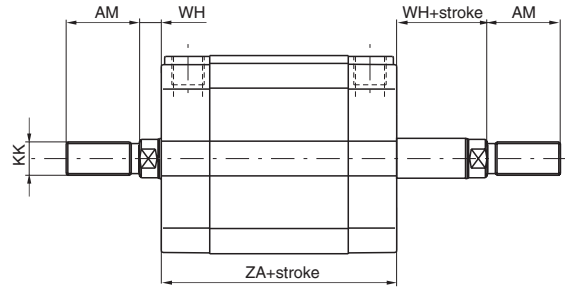

Push - pull version bored male piston rod

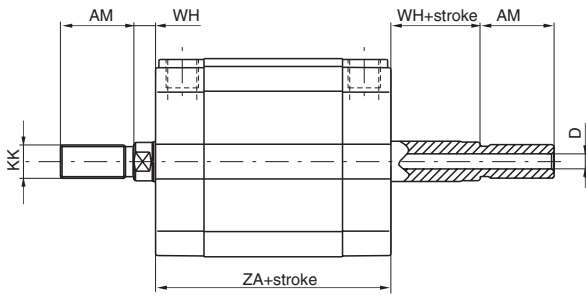

Push - pull version bored female piston rod

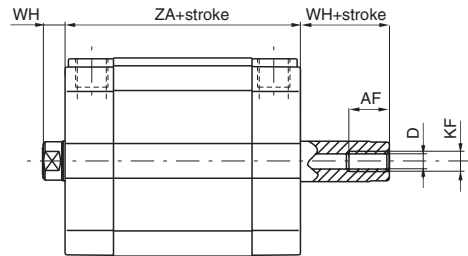

Maximum allowed stroke = ZB (see table)

Non-rotating version

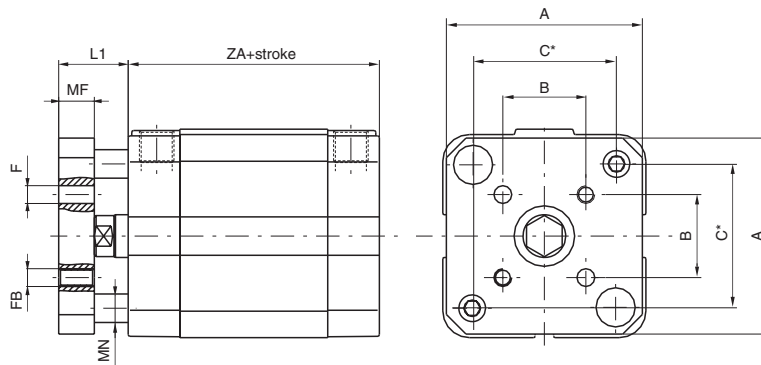

* = Distance between rods centres

| | | | | | | | | | | |
|------|------|---------|----------|----------|----------|----------|----------|----------|---------|---------|
| Bore | 12 | 16 | 20 | 25 | 32 | 40 | 50 | 63 | 80 | 100 |
| A | 28,5 | 28,5 | 35,5 | 39,5 | 45 | 55 | 65 | 80 | 100 | 120 |
| AF | 6 | 8 | 10 | 10 | 12 | 12 | 12 | 12 | 16 | 20 |
| AM | 16 | 20 | 22 | 22 | 22 | 22 | 24 | 24 | 32 | 40 |
| B | 9,9 | 9,9 | 12 | 15,6 | 19,8 | 23,3 | 29,7 | 35,4 | 46 | 56,6 |
| C | 18 | 18 | 22 | 26 | 34 | 40,5 | 49 | 59,5 | 77 | 94 |
| D | 2,3 | 3,2 | 3,8 | 3,8 | 4,5 | 4,5 | 6 | 6 | 8 | 10 |
| F | 3 | 3 | 4 | 5 | 5 | 5 | 6 | 6 | 8 | 10 |
| FB | M 3 | M 3 | M 4 | M 5 | M 5 | M 5 | M 6 | M 6 | M 8 | M 10 |
| KF | M 3 | M 4 | M 5 | M 5 | M 6 | M 6 | M 8 | M 8 | M 10 | M 12 |
| KK | M6X1 | M8X1,25 | M10X1,25 | M10X1,25 | M10X1,25 | M10X1,25 | M12X1,25 | M12X1,25 | M16X1,5 | M20X1,5 |
| L1 | 10,5 | 10,5 | 12,5 | 13,5 | 16 | 16,5 | 19,5 | 19,5 | 22 | 24 |
| MF | 6 | 6 | 8 | 8 | 10 | 10 | 12 | 12 | 14 | 14 |
| MN | 5 | 5 | 6 | 6 | 8 | 8 | 10 | 10 | 12 | 12 |
| WH | 4,5 | 4,5 | 4,5 | 5,5 | 6 | 6,5 | 7,5 | 7,5 | 8 | 10 |
| ZA | 38 | 38 | 38 | 39,5 | 44,5 | 45,5 | 45,5 | 50 | 56 | 66,5 |
| ZB | 20 | 25 | 50 | 50 | 50 | 50 | 75 | 75 | 80 | 80 |