

Flat Suction Pads (Round)



Suction Plates SPK

Suction area (Ø) from 55 mm to 250 mm



Suitability for Industry-Specific Applications



Suction plates SPK

Applications

- Round suction plate for handling of objects with very rough or structured surfaces (such as ornamental glass, checker plate, broken natural stone, etc.)
- Deactivation of unused suction plates by sensing valves (accessory)

Design

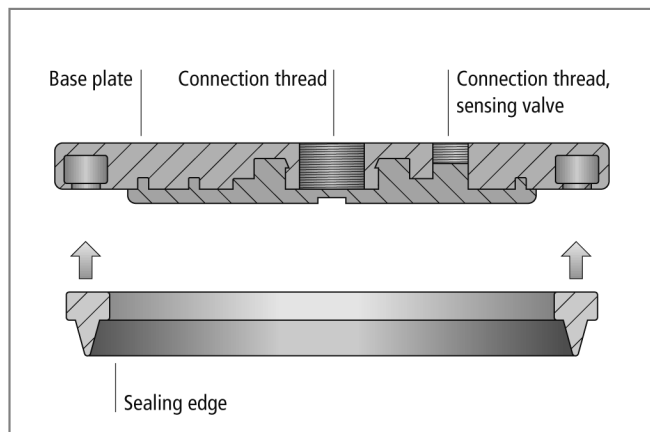

System design suction plates SPK

- Robust and wear-resistant suction plate SPK, consisting of flexible MOS sealing ring made of EPDM and aluminium base plate
- Sealing ring without seams
- Sealing ring is securely clipped into the base plate
- When worn, the sealing ring can be replaced separately
- Lower side of base plate with elastomer insert to prevent damage to workpieces
- Threaded hole for vacuum connection or sensing valve (off-center) sealed with a plug in the factory
- Sensing valve can be ordered as an accessory and is easily mounted, use medium-strength locking compound

Our Highlights...

- Sealing lip made of flexible EPDM
- Sealing ring clipped securely into the mounting plate
- Support on the bottom
- Low intrinsic volume
- Wide range of different diameters

Your Benefits...

- > Optimal adaptation to structured surfaces
- > Quick replacement of the sealing element
- > No permanent deformation of thin-walled workpieces
- > Very short cycle times
- > Wide range of pads for handling different workpieces

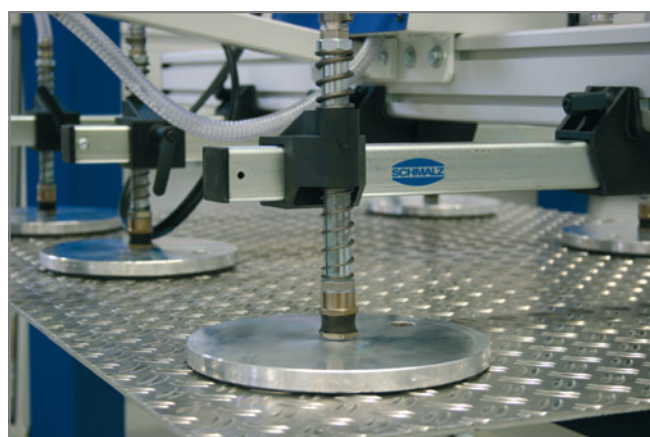

Suction plates SPK being used for handling corrugated sheet metal

Schmalz - The Company
 Vacuum Knowledge
Vacuum Suction Pads
 Special Grippers
 Mounting Elements
 Vacuum Generators
 Valve Technology
 Switches and Monitoring
 Filters and Connections
 Vacuum Gripping Systems
 Services
 Contact
 Index of Products

Flat Suction Pads (Round)



Suction Plates SPK

Suction area (Ø) from 55 mm to 250 mm

Designation Code Suction Plates SPK

Abbreviated designation	Suction area Ø in mm	Material and Shore hardness	Connection thread
Example SPK 110 MOS-15 G1/2-IG:			
SPK	110	MOS-15	G1/2-IG
SPK	55 to 250	MOS-15	G1/4-IG (IG = female (F)) G1/2-IG

Ordering Data Suction Plates SPK

Suction plate SPK (sealing ring + support plate) is delivered assembled. The assembly consists of:

- Sealing ring of type DR-SPK – elastomer part, available in various diameters
- Aluminium support plate, available with various threads

Available spare parts: sealing ring DR-SPK

Available accessories: sensing valve

Suction Plates SPK

Type	Part Number
SPK 55 MOS-15 G1/4-IG	10.01.01.12060
SPK 80 MOS-15 G1/4-IG	10.01.01.12061
SPK 110 MOS-15 G1/2-IG	10.01.01.12062
SPK 160 MOS-15 G1/2-IG	10.01.01.12063
SPK 200 MOS-15 G1/2-IG	10.01.01.12064
SPK 250 MOS-15 G1/2-IG	10.01.01.12065

Ordering Data Spare Parts And Accessories Suction Plates SPK

Type	Sealing ring DR-SPK	Sensing valve
SPK 55 MOS-15 G1/4-IG	10.01.01.12072	-
SPK 80 MOS-15 G1/4-IG	10.01.01.12073	10.05.10.00061
SPK 110 MOS-15 G1/2-IG	10.01.01.12074	10.05.10.00061
SPK 160 MOS-15 G1/2-IG	10.01.01.12075	10.05.10.00061
SPK 200 MOS-15 G1/2-IG	10.01.01.12076	10.05.10.00038
SPK 250 MOS-15 G1/2-IG	10.01.01.12077	10.05.10.00038

Technical Data Suction Plates SPK

Type	Suction force [N]*	Volume [cm ³]	Min. curve radius [mm] (convex)	Recom. internal hose diameter d [mm]**
SPK 55 MOS-15 G1/4-IG	121	15	250	9
SPK 80 MOS-15 G1/4-IG	256	32	300	9
SPK 110 MOS-15 G1/2-IG	471	67	-	12
SPK 160 MOS-15 G1/2-IG	1060	128	-	12
SPK 200 MOS-15 G1/2-IG	1700	198	-	12
SPK 250 MOS-15 G1/2-IG	2714	305	-	12

*The specified suction forces are theoretical values at a vacuum of -0.6 bar and with a smooth, dry workpiece surface - they do not include a safety factor

**The recommended hose diameter refers to a hose length of approx. 2 m

Flat Suction Pads (Round)



Suction Plates SPK

Suction area (\emptyset) from 55 mm to 250 mm



Design Data Suction Plates SPK

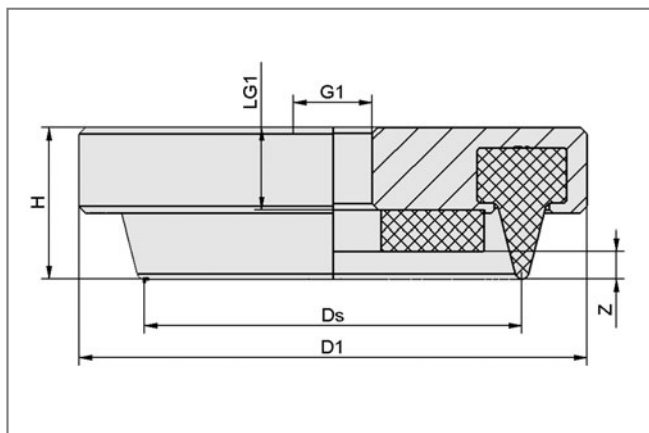

SPK 55

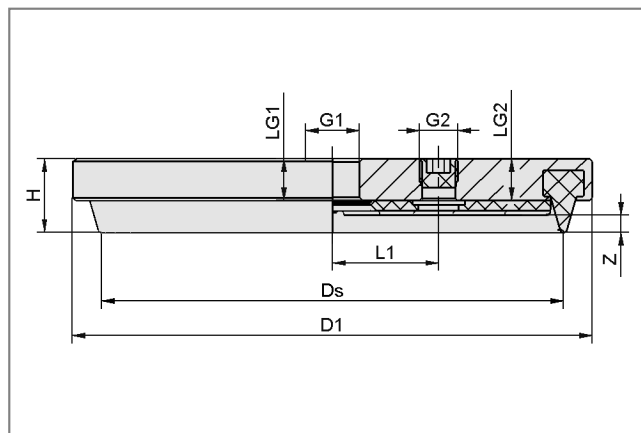

SPK 80 to 250

Type	Dimensions in mm*								
	D1	Ds	G1	G2**	H	L1	LG1	LG2	Z (Stroke)
SPK 55 MOS-15 G1/4-IG	70	55	G1/4"-F	-	22.0	-	11.5	-	4
SPK 80 MOS-15 G1/4-IG	95	80	G1/4"-F	G1/4"-F	22.0	22.0	11.5	11.5	4
SPK 110 MOS-15 G1/2-IG	130	110	G1/2"-F	G1/4"-F	25.5	36.5	14.5	14.5	6
SPK 160 MOS-15 G1/2-IG	179	159	G1/2"-F	G1/4"-F	25.5	36.5	14.5	14.5	6
SPK 200 MOS-15 G1/2-IG	219	199	G1/2"-F	G1/2"-F	25.5	76.0	14.5	14.5	6
SPK 250 MOS-15 G1/2-IG	269	249	G1/2"-F	G1/2"-F	25.5	76.0	14.5	14.5	6

*Acceptable dimensional tolerances for rubber sealings concerning to DIN 3302 - M4

**A plug is fitted in this connection in the factory

- Schmalz - The Company
- Vacuum Knowledge
- Vacuum Suction Pads**
- Special Grippers
- Mounting Elements
- Vacuum Generators
- Valve Technology
- Switches and Monitoring
- Filters and Connections
- Vacuum Gripping Systems
- Services
- Contact
- Index of Products