

HYVA PISTON PUMPS



BENT AXIS TYPE

Hyva

piston pump type :

piston pump 080L - R - 4H

part number :

145 64 630

page # 1 / 2

rotation :

clock wise seen from front side of pump

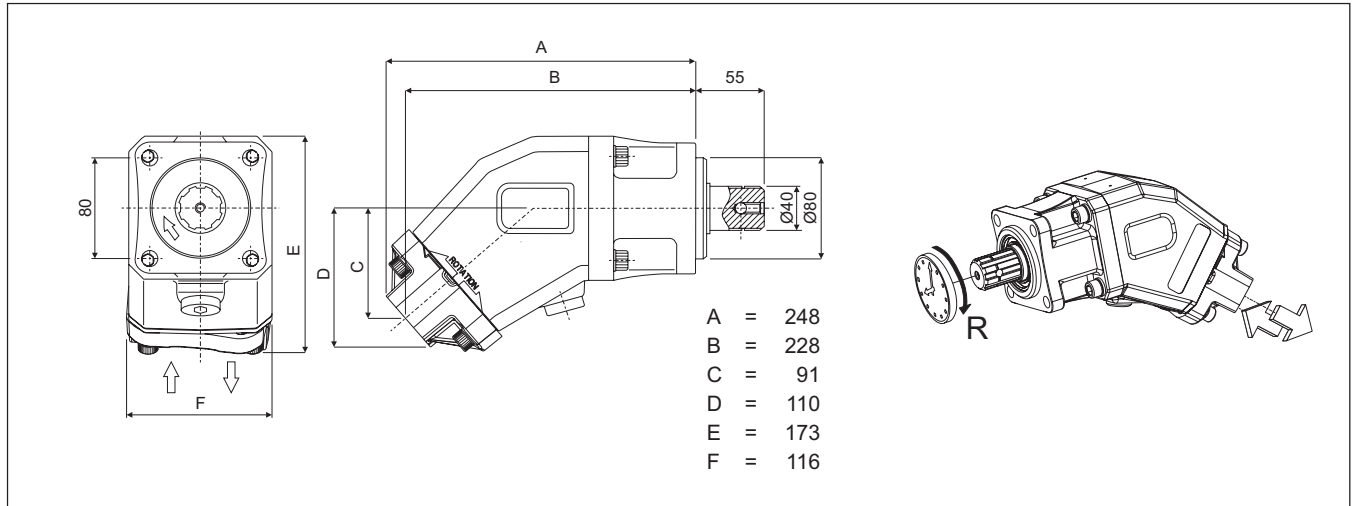

specifications

displacement per revolution	:	78,3	cm ³
maximum peak pressure	:	350	bar
maximum intermittent pressure	:	315	bar
maximum continuous pressure	:	240	bar
maximum self priming speed	:	1300	min ⁻¹
max. speed at intermittent press.	:	2000	min ⁻¹
min. speed at intermittent press.	:	350	min ⁻¹
oil temperature range	:	-25 ⇔ 80	°C
inlet pressure range (suction side)	:	0,85 ⇔ 2	bar (abs)
recommended oil viscosity range	:	10 ⇔ 400	mm ² /s (cSt)
maximum starting viscosity	:	1000	mm ² /s (cSt)
filtration :			
- working pressure < 200 bar	:	25	µm
- working pressure > 200 bar	:	10	µm
connection :			
- inlet - straight internal thread	:	1	" B.S.P.
- outlet - straight internal thread	:	0,75	" B.S.P.
minimum suction hose bore diameter	:	2	inch
shaft DIN 5462 spline	:	8*32*36	mm
mass	:	10	kg
noise level at 900 min ⁻¹ and 100 bar	:	66,9	dB(A)
noise level at 1500 min ⁻¹ and 100 bar	:	66,7	dB(A)

working speed depends on hose size

pressure definition

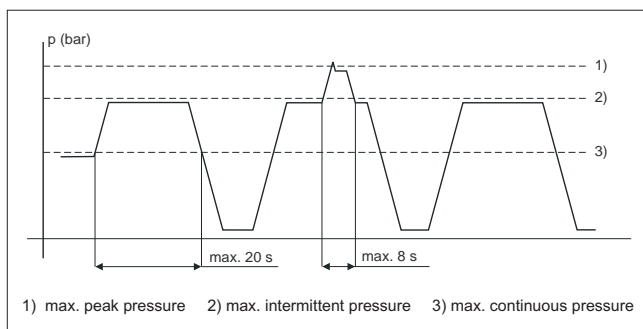

power and torque

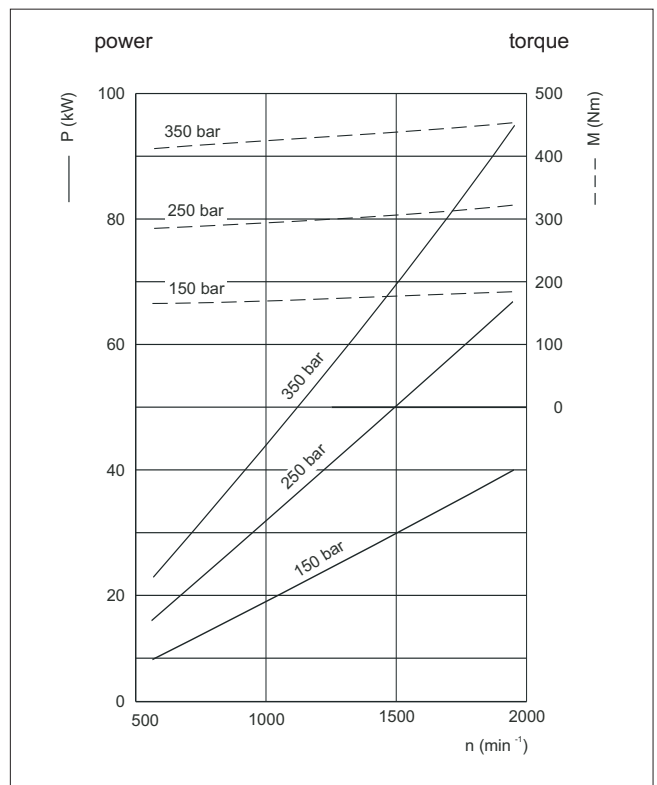

hydraulic pump symbol

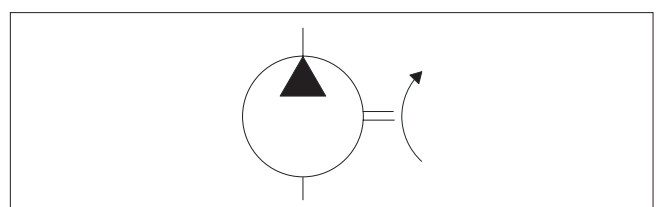

subject to change without notice

DO-E 14564630 / 06 03 29 / RV AB

HYVA PISTON PUMPS



BENT AXIS TYPE

Hyva	piston pump type :	piston pump 080L - R - 4H
page # 2 / 2	part number :	145 64 630
	rotation :	clock wise seen from front side of pump

drawing for part number reference only

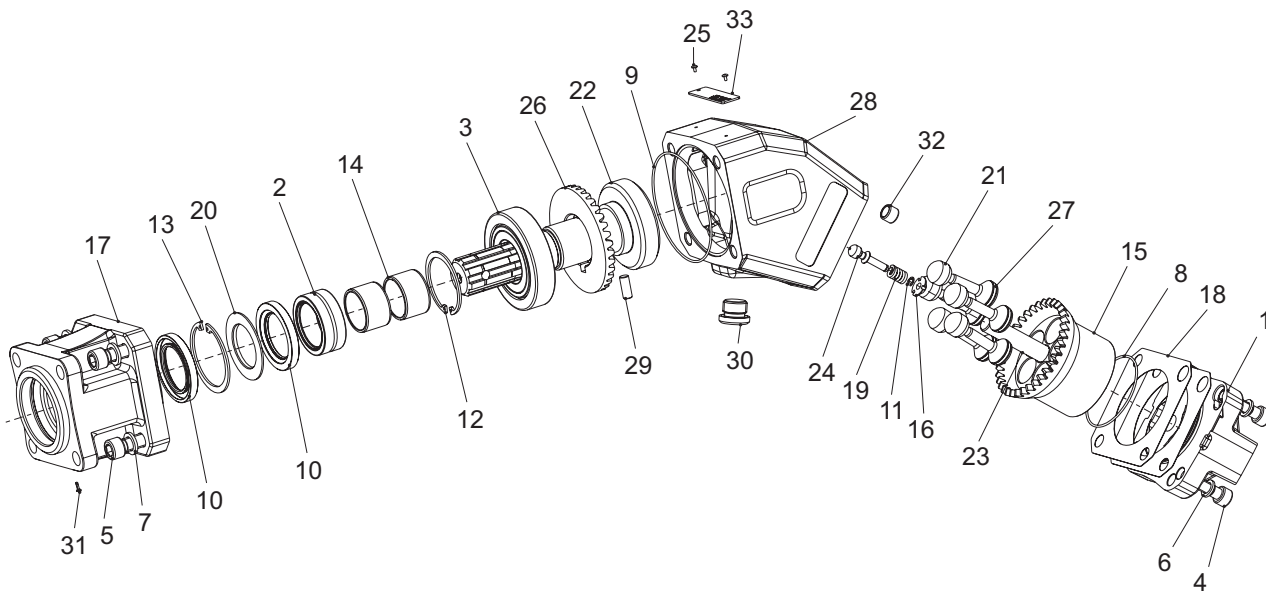

Check if you have a rear cover (pos. 1) with 4 or 8 mounting holes.
If you need parts for a pump with a 4 holes cover contact Hyva or your local agent.

spare part list piston pump 145 64 630

pos.	code no.	description	qty.
1		rear cover	1
2		bearing	1
3		conic roller bearing	1
4		screw	4
5		screw	4
6		washer	4
7		washer	4
8		OR seal	1
9		OR seal	1
10		Viton seal	2
11		circlip	1
12		circlip	1
13		circlip	1
14		ring	2
15		cylinder block	1
16		centering lock	1
17		flange	1
18		seal side cover	2
19		centering spring	1
20		keep plate	1
21		piston	5
22		shaft	1
23		pin	1
24		dowel pin	1
25		rivet	2

spare part list piston pump 145 64 630

pos.	code no.	description	qty.
26		gear	1
27		segment	5
28		pump body	1
29		dowel pin	1
30		steel plug	1
31		protection plug	1
32		steel bush	1
33		name plate	1
	024 70 800	seal kit (comprises 8, 9, 10,18 & 20)	1

general information and mounting possibilities.

The mentioned data on page 1 is for mineral based oil.
For other fluids, please contact our engineering dept.

The filtration as mentioned is for tippers only. For different applications we advise filtration according ISO 4406 class 17/14.

To avoid cavitation, the suction hose must be kept as short and straight as possible, and the minimum oil level in the oil tank must be above the inlet of the pump.

The direction of rotation of this pump can be changed by a skilled (hydraulic) engineer.
For information please contact our engineering dept.