

PRESA DI FORZA A COMANDO PNEUMATICO

PNEUMATIC CLUTCH POWER TAKE-OFF

CODICE PTO
PTO CODE

28-25

CAMBIO
GEARBOX

SCANIA

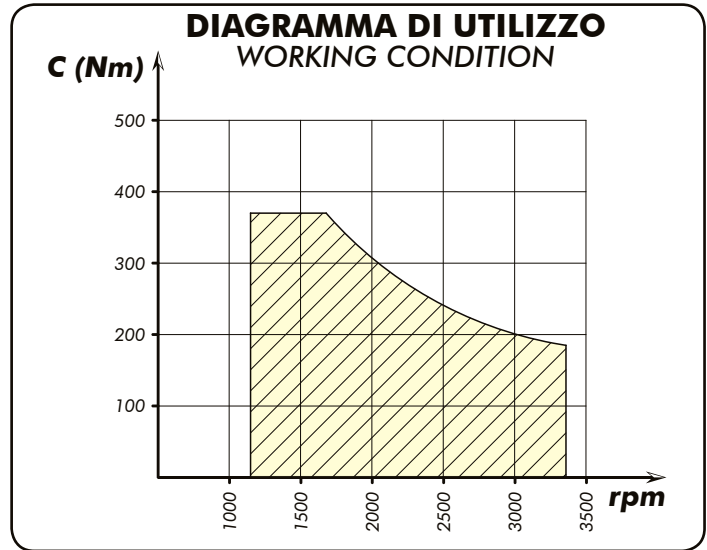

Interruttore segnalazione PTO inserita / PTO pressure signal switch



PACKARD
311-001-00116



DIN 72585
311-001-00205

*
OPTIONAL
Da ordinare separatamente
To be ordered separately

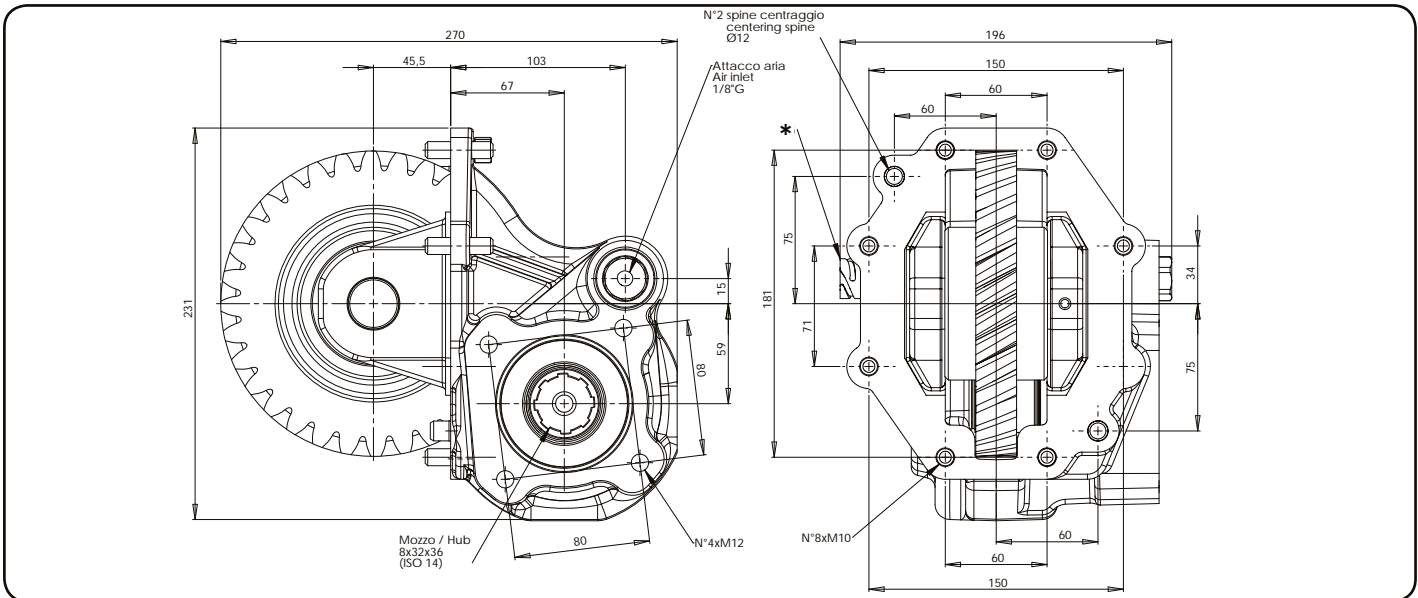

Tipo cambio Gearbox	Codice PTO PTO code	Versione Version	Giri pto a 1000 giri motore Pto ratio@1000 eng.rpm		Coppia massima Max torque Nm	Lato montaggio Mounting side	Uscita Output	Rotazione Rotation	Kit di montaggio Mounting kit
			NORM.	VEL.					
GRSO 905	28-25-173	17	1680	2015	370	Dx Right	Poster. Rear	Oraria Cw	154-3-3571

pag.1



O.M.F.B. S.p.A. Hydraulic Components
We reserve the right to make any changes without notice.
Edition 2010.01 No reproduction, however partial, is permitted.
Via Cave, 7/9 25050 Provaglia d'Iseo (Brescia) Italy Tel.: +39.030.9830611
Fax: +39.030.9839207-208 Internet:www.omfb.it e-mail:info@omfb.it

COMPANY WITH
QUALITY SYSTEM
CERTIFIED BY DNV
= ISO 9001 =

UŽSISAKYKITE internetu www.dominga.lt/eshop telefonu +370 5 2322231 el. paštu info@dominga.lt

Data: Lunedì 03 ottobre 2011

Codice foglio:997-228-02517 Rev: AA