



TECHNICAL DATA

ROTTNE F15^D



ENGINE

Type	JD 6068 HFC 08 Power Tech PVS, Final Tier 4 (FT4)
Output	164 kW / 220 hp at 1800 rpm
Torque	963 Nm (710 lb ft) at 1500 rpm
Cylinder volume	6.8 liter (415 in ³)
Diesel tank	165 litres (44 US gal)

TRANSMISSION

Type	D5 controlled hydrostatic/mechanical with full capacity control. 3 gear steps.
Tractive force	177 kN (39 800 lbf)
Speed, gear 1	0 - 5 km/h (0 - 3.1 mph)
Speed, gear 2	0 - 9.5 km/h (0 - 5.9 mph)
Speed, gear 3	0 - 25 km/h 0 - 15.5 mph)

BRAKES

Type	2-circuit electrically/hydraulically operated negative wet disc brakes. Automatic load brake. Spring-assisted parking and emergency brake.
------	--

WHEEL EQUIPMENT

8 WD	710/45 x 26.5
------	---------------

CHASSIS

Type	Central joint with slew bearing and mid lock. Bolted welded load bunks. Front headboard and first bunk hydraulically movable.
Steering angle	+/- 43°
Max. steering torque	74.9 kNm (55 240 lb ft)
Horizontal angle	+/- 20°

HYDRAULIC SYSTEM

Type	Load-sensing system, entirely separated from the transmission.
Pump capacity	210 litres (55 US gal) / 1500 rpm
Working pressure	3 - 22 MPa (435 - 3 200 psi)
Degree of filtration	10 micron
Tank volume	105 litres (28 US gal)

ELECTRICAL SYSTEM

Type	24 volt electrical system with CAN-bus technology.
Battery	2 x 142 Ah
Alternator	150 A
Machine control system	ROTTNE D5, with 9
Working lights	20 pcs

CAB

Type	Spacious, vibration-proof safety cab. ISO certified
Noise level	67 dBA
Climate system	ACC

CRANE

Type	Jib arm crane RK125 with dual slew cylinders and telescope 1.4 m / 2.4 m / double telescope.
Lifting torque	125 kNm (92 200 lb ft)
Angle of rotation	375°
Reach	7.2 / 8.4 / 10 m (23.5 / 27.5 / 33 ft)
Torque	35.8 kNm (26 400 lb ft)

WEIGHT AND DIMENSIONS

Service weight from	18 700 kg (41 225 lbs)
Width	2 890 mm (114 in)
Length	9 834 mm (387 in)
Transportation height	3 819 mm (150,5 in)
Ground clearance (at articulated frame lock)	668 mm (26 in)
Loading capacity	15 000 kg (33 100 lbs)
Loading area	4.8 - 5.7 m ² (52 - 61 ft ²)

We reserve the right to make changes to the technical data and equipment. Images and specifications do not always show the machine in standard version.

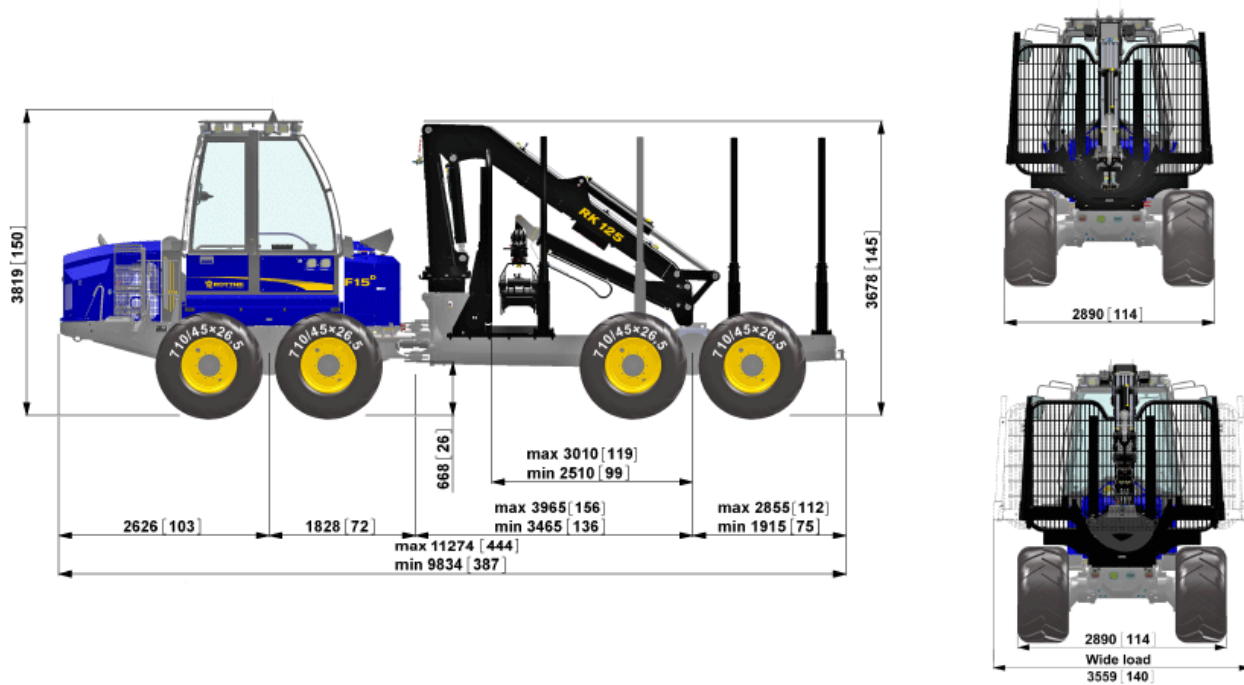

EQUIPMENT

Active Load Space ALS, Chains, Lighting Xenon or LED, Sprinklers , Engine/cab heater, Blinds , Mobile telephone, Vacuum pump , Reversing camera, GPS/Geoinfo, Filler pump, Green oil, Colour printer , Mobile broadband, Orbitrol steering, Full toolkit, Central lubrication, Tracks, Forwarder computer, Extended wagon frame, Extra load bunk, Load bunks "Wide load", Cab damping system COMFORT LINE, Dozer blade, Double telescope, Balanced bogie system, Bogie lift,

Contact your local dealer for more information. www.rottnet.com

